

AAS58...S / AAM58...S



Main features:

- SSI interface, industrial encoder
- Multi-turn tech: Gear Box, no count, no battery
- Zero setting and counting direction setting function

Extensive Application:

- ✓ Speed sensing, angle, distance, locus, tilt
- ✓ Radar angle measurement, hydraulic engineering survey
- ✓ Solar electrical energy generation
- ✓ Day tracking system feedback
- ✓ Iron and steel metallurgical equipment,
- ✓ Port lifting and transportation machinery, factory automation
- ✓ Use in non-explosion proof environment

Mechanical specifications

Qualification

Material	Shell: Aluminum shell	EMC:
	Flange: Aluminum shell	Emitted interference: EN61000-6-4
	Shaft: Stainless steel	Noise immunity: EN61000-6-2
Maximum shaft load	Max 80N Axial	ISO9001:2015
	Max 150N Radial	CE authentication
Levels of protection	IP65	
Starting torque	25°C, ≤0.5Nm	
Maximum speed	6000RPM	
Impact resistance	≤ 100g ,3ms	
Anti-vibration	≤ 10g (10Hz—2000Hz)	
Weight	≈300g	
Working temperature	-40°C ... +80°C	
Storage temperature	-40°C ... +85°C	

Electrical specifications

Interface type	SSI synchronous serial interface
Output code system	Gray code or Binary code
Output circuit	RS422 compliant line driver
Clock frequency	100KHz - 1MHz
Data refresh	Single-turn encoder: < 15us ; Multi-turn encoder: < 1.3ms
Working voltage	10-30VDC or 5VDC; polarity protection
No-load current	≤50mA
Repeatability precision	±2bit(It is related to the actual precision, installation precision and axis concentricity)
Steps per revolution	≤ 13 bits 8192 (14 bits 16384 customizable);
Revolutions (turn)	≤14 bits 16384
Counting direction	0V: Clockwise data increase. VCC: Counter clockwise reduction
External position	When in short contact with VCC, position takes effect, time > 100ms

Interface type: SSI

Clock/Data: Four-wire RS422 mode, $\pm 5V$, a pair of clock triggers, a pair of data output.

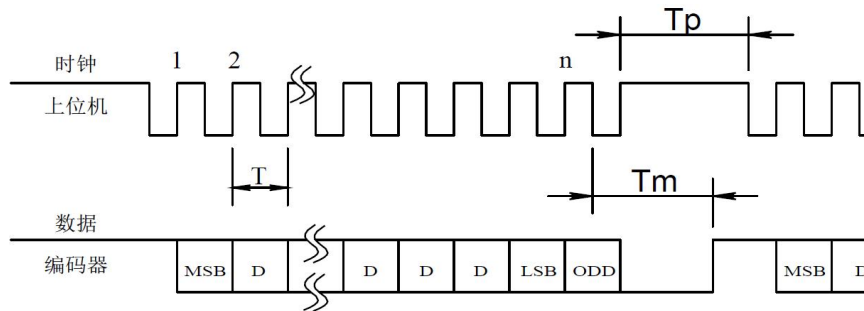

$T=1/f$ clock cycle $\leq 1\text{MHz}$	MSB=High data bits (Number first)
T_p =Clock gap > Monostable trigger time	LSB=Low data bit (Data end)
T_m =Monostable trigger time 10 μs –30 μs	ODD=check bit

About ODD (check bit) :

To verify the correctness of the data during transmission, we added a bit at the end of the data;

Multiple turn 1213 (25bit) :

When n equals 25 bits, the data output from high to low (MSB--LSB) has no output.,

When n equals 26 bits, the data end adds a bit check bit odd output after LSB.

Data processing (Gray code as an example.)

➤ Single turn data processing:

The encoder outputs a Gray code, which is first received and decoded into binary code from the high position in an XOR manner. Encoder installation does not require change. After installation, when the equipment runs to the mechanical zero point, the P-SET line of the core line of the encoder cable and the power supply are touched short. The current signal is the actual position of the encoder output, which can be calculated.

➤ Multi - turn data processing:

The encoder output is gray code and decodes it into binary code from high bit. To avoid sudden change of data in working stroke, it is suggested to use the middle position of encoder data value as the starting position. When the encoder is installed, the equipment runs to the starting point, and the P-SET line of the encoder cable is in direct contact with the power supply, and the current signal. The output is the median value of the encoder's total output value, and the P-SET line goes back to the power supply 0.

After the current measurements received are converted to binary codes, the following should be done:

➤ Upper computer position value = (DATE - P-SET) \times Dir + Starting point value

In the formula, DATE: Current measurements of encoder output; P-SET: Intermediate position value, 为 2^{n-1} ,

Dir: The coefficient of rotation direction for the encoder, and the direction of calculation

The same is 1, the opposite direction of calculation is -1, and the connection level can be changed by the Dir line on the encoder. Example: Multi-loop 1213 encoder, after the encoder is set at the starting point (or any position required for measurement), The output of the encoder is $2048 \times 8192 = 16777216$,

P-EST is a fixed value of 16777216. If the starting value is set to 0, the rotation direction is a clockwise pointer.

Upper computer position value is $(16777216 - 16777216) \times 1 + 0 = 0$

At this point, clockwise rotation encoder data increases, 1, 2, 3...

Data reduction of counterclockwise rotary encoder, -1, -2, -3...

16777216It is decimal, but it is convenient to explain that the encoder actually outputs Gray code or binary code

➤ The starting point is not zero, and the calibration position can be determined by the user. Since the multi-loop encoder can have 4096 cycles of continuous measurement, from the starting point, the forward inversion can have 2048 cycles of continuous working stroke.

Wiring mode and points for attention

1. Wiring definition

Signal	VCC	0V	Clock+	Clock-	Data+	Data-	P-set	Dir
Cable	Brown	White	Green	Yellow	Grey	Pink	Blue	Red
Seat	2	1	3	4	5	6	7	8

- 1) P-set external position line

Single-turn encoder: when short contact with VCC, the current position data is output to the zero position of the entire data; (Customizable: single-turn midpoint)

Multi-turn encoder: When a short touch with VCC, the current position data output is the mid-point position of the entire data; (Customizable: Multi-turn 0-point position)



M23

plug(12pin)

- 2) Dir Counter direction line: when VCC is connected: counterclockwise data increases in face of rotating axis;
0 V: clockwise data increase
- 3) Shield: Internal default suspension

2. Attention:

- 1) Encoder is a precision instrument, do not tap, impact or drop encoder, especially in the hinge end, please handle lightly, use carefully.
- 2) Ensure that the encoder power supply within the selected supply voltage range, and do a good job of isolation, to prevent large electric power grid in the impact of the encoder.
- 3) In the environment of strong electromagnetic interference, the extended signal line should use the twisted-pair shielded cable.
- 4) SSI signal lines are voltage-protected and should be used to prevent signal lines from being shortened or short-connected to the power supply.
- 5) It is forbidden to plug in and out and ensure that the cables are connected at the same time.
- 6) The encoder must be powered off without electrostatic soldering or connection, first welded or connected to the 0V line;
- 7) The encoder has a protection class of IP65 and is waterproof, but do not submerge the encoder shaft!

Selection instructions

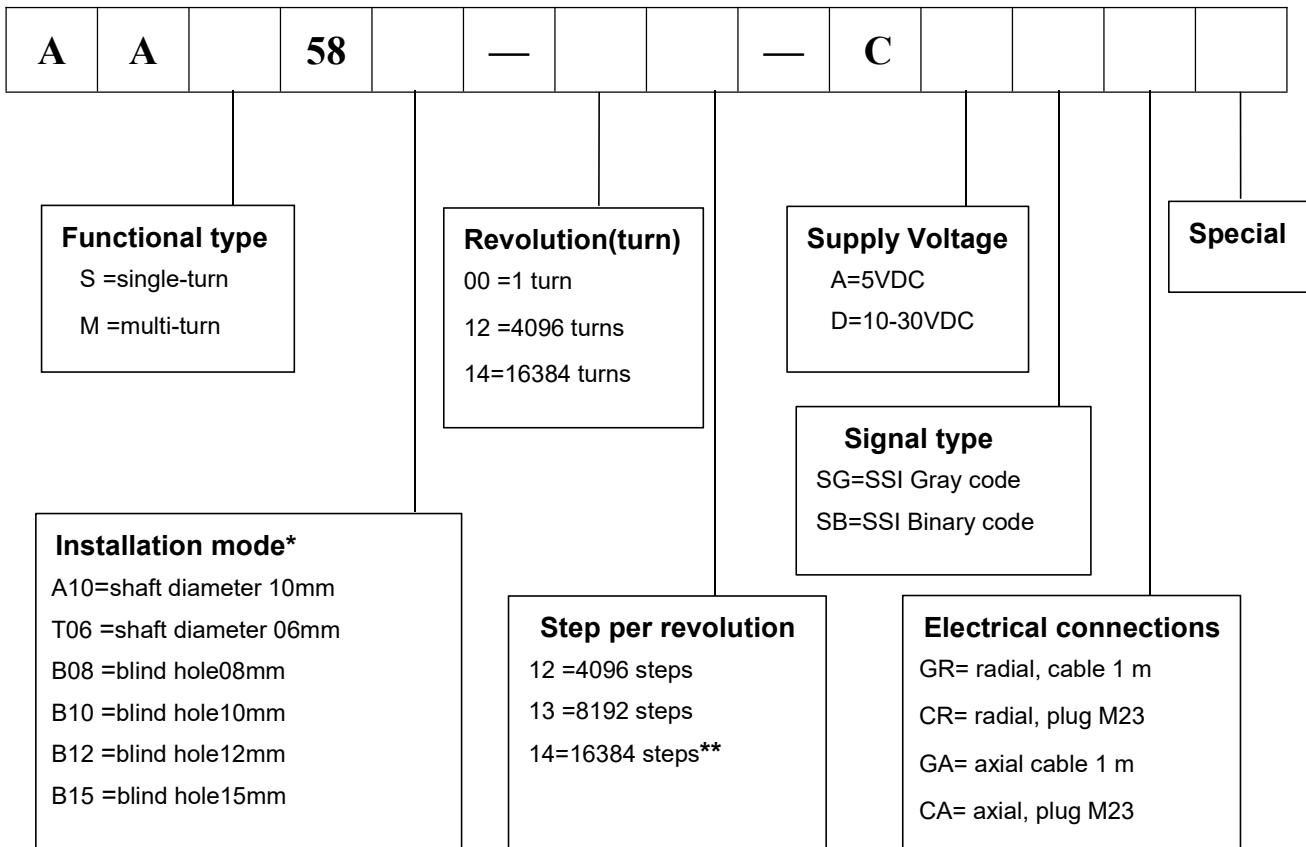

* A=Clamping synchronous flange, T=Synchronous flange, B=Blind hole

** Revolution 14 bits (16384) customizable

Mechanical dimension

Unit: mm

Clamping synchronous flange (58A10) ↓	Cable output	M23 plug output
---------------------------------------	--------------	-----------------

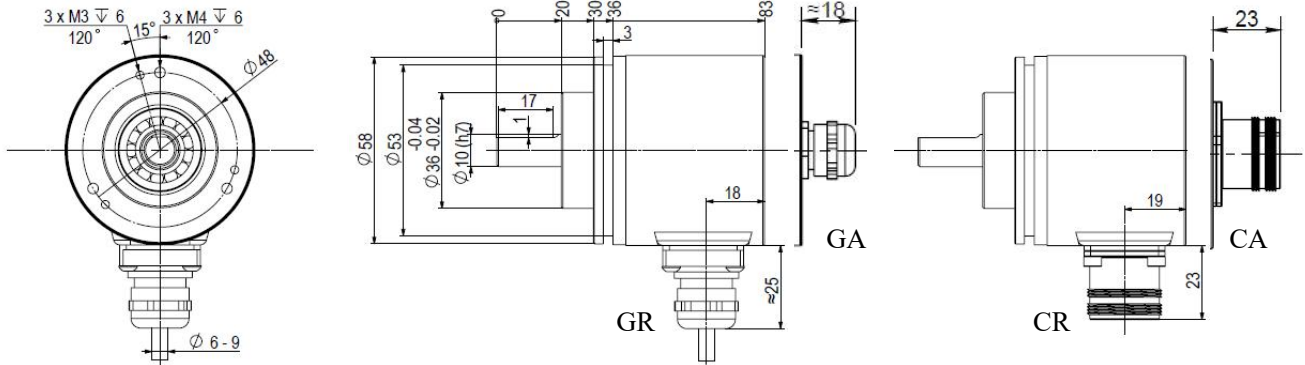

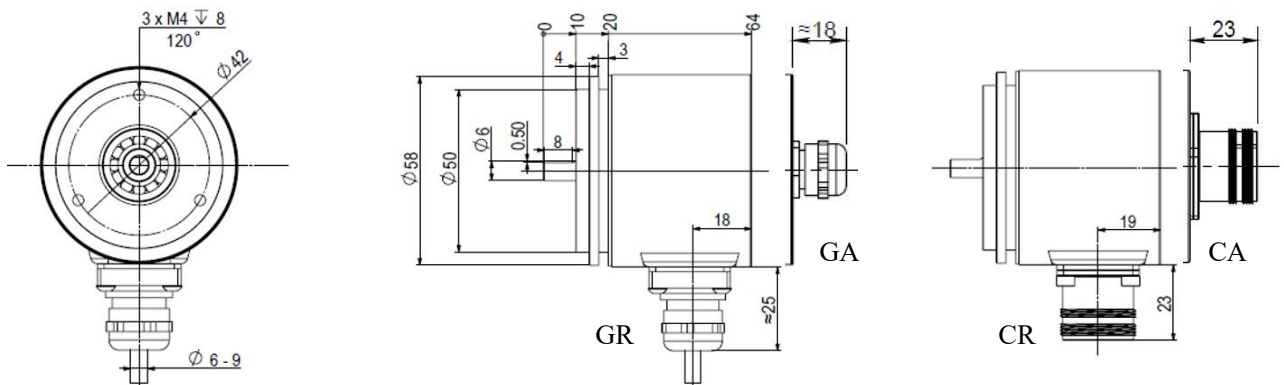

Synchronous flange (58T06) ↓	Cable output	M23 plug output
------------------------------	--------------	-----------------

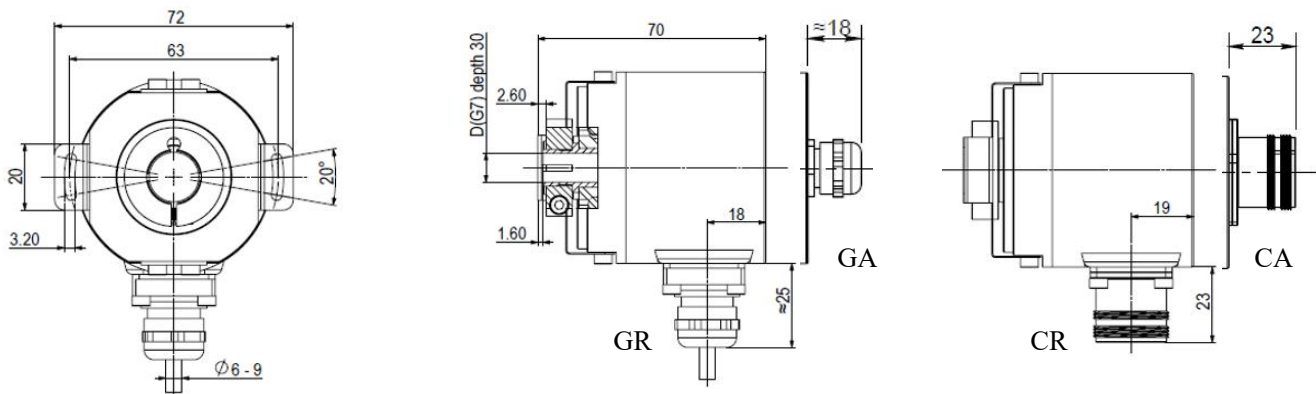

Blind hole (58B) ↓	Cable output	M23 plug output
--------------------	--------------	-----------------



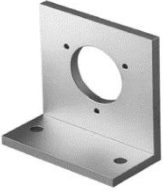

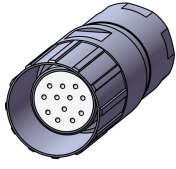
Accessories (Please refer to the attached information for more information)			
Mounting brackets	Stainless steel couplings	Spring steel couplings	M23 plug
			
MODEL AZJ80	AL4A-B	AL3B	C12C
Apply to 58A	58A&58T	58A&58T	M23 plug