

opk Speedboat G InSide

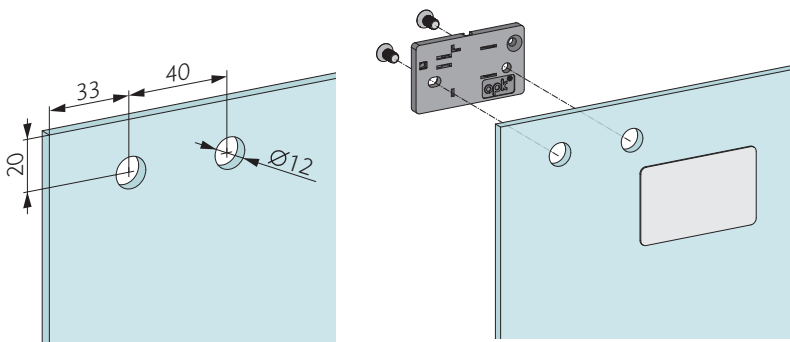

Technische Zeichnung Technical drawing

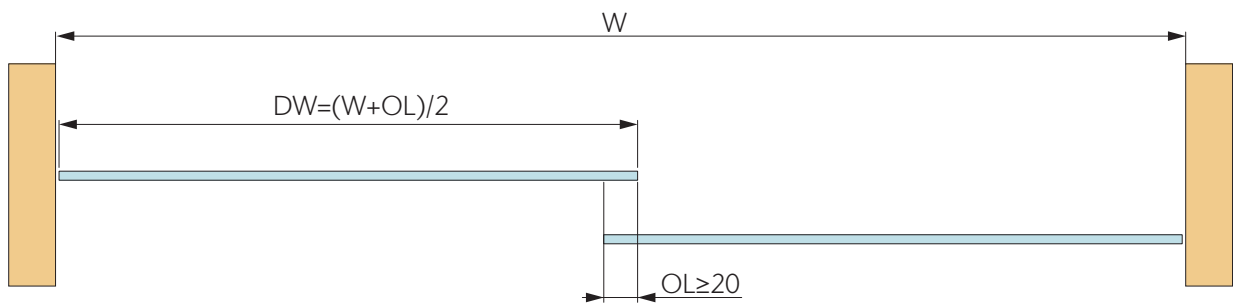
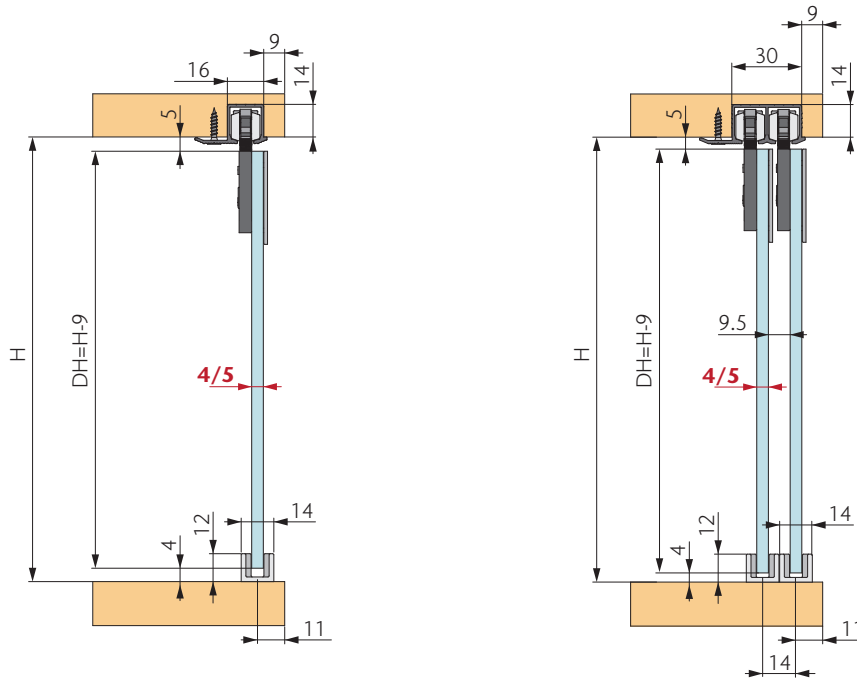

Einseitige Dämpfung
One side damping

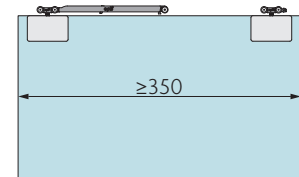

Beidseitige Dämpfung
Both sides damping

