

● Features 特点

- Smallsize but large capacity 小尺寸大容量
- Low ESR 低内阻
- PB Free and RoHS Complaint 无铅环保符合 ROHS



Application 应用

- Solar voltaic application 太阳能光伏应用

( e.g. Traffic sign “LED type”. Road guidance flasher)

- Motor Drive through quick discharge,Instrumentation, military equipment, Medical equipment

马达驱动、仪器仪表、军事装备、医疗设备

( e.g. toy car & plane)

- Emergency power supply for car DVR or black box 后备电源 , 汽车电子摄像头 GPS 等

● Specifications 参数

Items	Characteristics
Rated working voltage	2.7 VDC(Max 3V Peack)
Operating temperature	-40 to +70 °C hot-shock 85°C
Capacitanc	5F
Capacitance tolerance	-20% to +40% (at 25 °C)
Endurance	Capacitance change:±30% of initialmeasured value Internalresistance:≤200% ofspecified value (After 1,000 hours application of rated DC working voltage at +70/+85 °C,the capacitor shall meetthe following limits)

Shelflife	After 1,000 hours storage at +70/+85°C without load, the capacitor shall meet the specified limit for "Endurance"
-----------	---

● Shape of Standard Product 尺寸

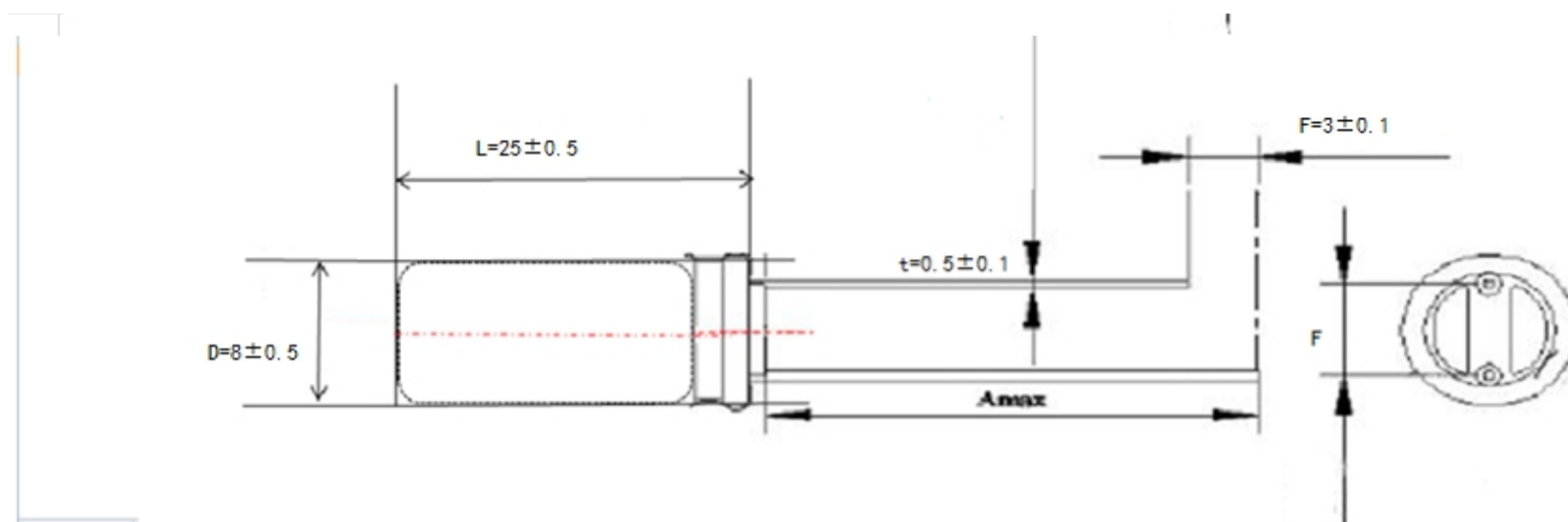

● Standard Products and Dimensions (not to scale)

Part number	Operating voltage(V)	Capacitance(F)	ESR( ,@1kHz)	φ DxL(mm)	t(mm)	F(mm)
ODR 2R7 505	2.7	5.0	< 0.2	Φ8x25.0	0.5	3.0

● Test method 测试方法

1. According to the standard: 依据标准  
 QC/T 741-2014 《SUPERCAPACITOR FOR CAR SYSTEM》 《车载应用超级电容》  
 DL/T 1652-2016 《Technical specifications for supercapacitors for energy measurement equipment》  
 《电能检测设备超级电容技术规范》

2. Capacitance 容量

constant current discharge method 恒流放电测试法

3. Measuring circuit 测试电路

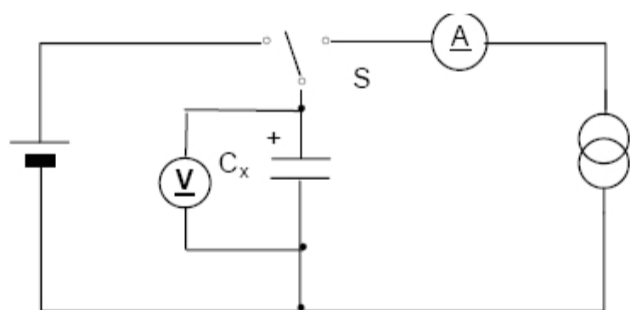

- Ⓐ 直流电流表 DC ammeter
- Ⓥ 直流电压表 DC voltmeter
- S 转换开关 Transfer switch
- C<sub>x</sub> 待测电容 Capacitance under test

图1 - 恒流放电方法电路 Constant current discharge method circuit

测量方法 measuring method

◎ 恒流/恒压源的直流电压设定为额定电压 (UR)

The DC voltage of the constant current / constant voltage source is set to the rated voltage (UR).

设定表1中规定的恒电流充放电装置的恒定电流值。

◎ Set the constant current value of the constant current charge and discharge device specified in Table 1.

◎ 将开关S切换到直流电源，在恒流/恒压源达到额定电压后恒压充电30min。

◎ Switch S to DC power supply, and charge at constant voltage for 30 minutes after the constant current / constant voltage source reaches the rated voltage.

◎ 在充电结束后，将开关S变换到恒流放电装置，以恒定电流进行放电。

◎ After charging is completed, switch S is switched to a constant current discharge device, and discharge is performed at a constant current.

◎ 测量电容器两端电压从U1到U2的时间t1和t2，如图2所示，根据下列等式计算电容量值：

Measure the time t1 and t2 of the voltage across the capacitor from U1 to U2, as shown in Figure 2, calculate the capacitance value according to the following equation



图2 电容器的端电压特性

$$C = \frac{I \times (t_2 - t_1)}{U_1 - U_2}$$

C 容量 (F) capacitance

I 放电电流 (A) ; discharge current

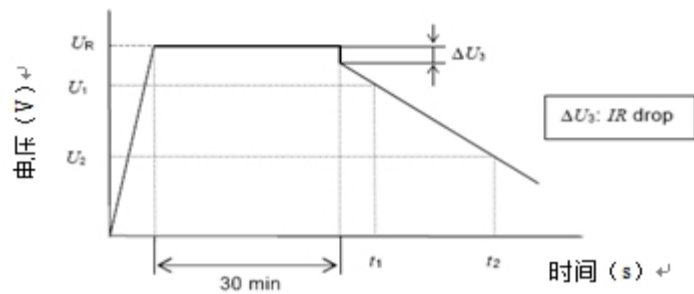
U1 测量初始电压 (V) ; test initial voltage

U2 测量终止电压 (V) ; test terminal voltage

t1 放电电压达到U1的时间 (s) ; time of the voltage drop to U1

t2 放电电压达到U2的时间 (s) 。 time of the voltage drop to U2

放电电流I及放电电压下降的电压U1和U2参见表1。

表1 - 充放电条件 discharge conditions

分类	SE、HE、HT(叠片产品)	SP、HP、HT、LR	备注
应用	能量存储	瞬时功率、功率	$I_1 = \frac{C_R \times U_R}{3600}$
充电时间	30min	30min	
I (A)	$I = 5I_1$	$I = 40 I_1$	
U1	充电电压的80%值 (0.8 × UR)		
U2	充电电压的50%值 (0.5 × UR)		

备注:

CR为超级电容器的标称容量，单位为法拉 (F) ;

UR额定电压，单位为伏 (V) ;

I为充放电测试电流，单位为安培 (A) ;

I1为超级电容器1倍充放电电流，单位为安培 (A)

设备: A、ARBIN超电容测试系统 B、线性直流稳压电源C、恒流放电装置D、电压记录仪

3. 内阻 Internal resistance

测试方法: 交流阻抗方法

测量电路

所示测量电路进行测试。



图3 - 交流阻抗方法电路

## 测量方法

电容器的内阻 $R_a$ 应通过下式计算:

$$R_a = \frac{U}{I}$$

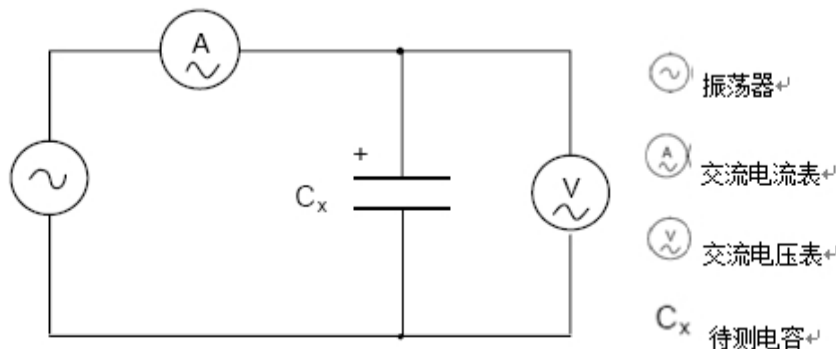
其中

$R_a$  交流内阻 ( $\Omega$ );

$U$  交流电压有效值 (V r.m.s);

$I$  交流电流有效值 (V r.m.s)。

测量电压的频率, 应为1kHz。

### ● Note for using: 使用注意事项

1. 超级电容器推荐按固定的极性使用, 万一反向, 不会造成爆破等危险, 但会缩减使用寿命;  
Supercapacitors are recommended to be used with fixed polarity. In case of reverse direction, it will not cause dangers such as explosion, but will reduce the service life.
2. 超级电容器应在标称电压下使用, 长时间过电压将导致永久性的损害;  
Supercapacitors should be used at nominal voltage and overvoltage will cause permanent damage.
3. 超级电容器不可应用于高频率充放电的电路中, 而是用于直流储能及放电电源使用;  
Supercapacitors are not suitable for high frequency charging and discharging circuits, but for DC energy storage and discharging power supply.
4. 环境温度影响超级电容器的寿命, 上限温度和上限电压同时着用, 对产品寿命有缩减作用;  
The ambient temperature affects the lifetime of the supercapacitor. The upper temperature and the upper voltage are used simultaneously, which can reduce the lifetime of the product.
5. 在放电的瞬间存在电压降  $\Delta V=IR$ , 内阻越大, 电压降幅度越明显;  
There is voltage drop  $V=IR$  at the instant of discharge. The larger the internal resistance, the more obvious the voltage drop.
6. 不可存放于相对湿度大于 85%或含有有毒气体, 易燃易爆气体等场所;  
Do not store in places with relative humidity greater than 85% or containing toxic gases, inflammable and explosive gases, etc.
7. 产品应储存在温度 $-30^{\circ}\text{C}\sim 50^{\circ}\text{C}$ 、相对湿度小于 60%的环境中;  
The product should be stored in an environment with temperature  $-30\sim 50\text{C}$  and relative humidity less than 60%.
8. 超级电容器用于双面电路板上时, 要注意连接处, 测试孔不可经过电容器可触及的地方, 导致短路;  
When using supercapacitors on double-sided circuit boards, attention should be paid to the connection, test holes can not pass through where the capacitors can reach, resulting in short circuit
9. 安装后, 不可强行硬扳或扭动或倾斜电容器, 导致电容内部结构受损, 将导致参数异常;  
After installation, the capacitor should not be forcibly wrenched or twisted or tilted, resulting in damage to the internal structure of the capacitor, which will lead to abnormal parameters.
10. 在焊接过程中要避免使电容器过热 (1.6mm 的印刷线路板, 焊接时应为  $280^{\circ}\text{C}$ , 时间不超过 3s)  
Avoid overheating capacitors during welding (for 1.6mm printed circuit boards,  $280^{\circ}\text{C}$  for no more than 3s)
11. 焊接后, 线路板和电容器要清洗干净, 建议使用免清洗焊锡, 免用助焊剂;  
After welding, the circuit board and capacitor should be cleaned clean. It is recommended to use non-cleaning solder and no solder flux.
12. 超级电容器串联使用时, 存在单体间的电压均衡问题, 采用主动均衡, 被动均衡;  
When supercapacitors are used in series, there is a voltage balance problem between the monomers. Active equalization and passive equalization are used.
13. 不允许进行回流 (IR, 电磁加热方法等) 过程;  
It is not allowed to go through reflow (IR, Atmosphere heating methods etc.) process;
14. 其它使用上的问题, 欢迎来电来信咨询。  
For other usage problems, please call us for advice.