

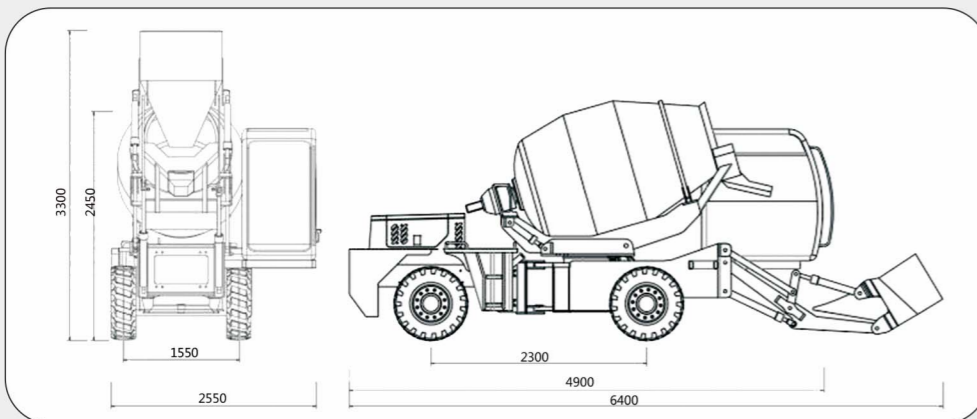

CMT1200

Self Loading Concrete Mixer

1.2m³, 0°



Main Technical Parameter			
Concrete Output	1200 L/batch	Productivity	5 batch/ hour , 6 m ³ / h
Total Drum Capacity	1800 L	Engine Power	58 kW
Front Shovel Capacity	500 L	Engine Type	YUNNEI, 490, Turbo-charged
Water Tank Capacity	2x200 L	Drive Type	4x4
Max.Drum Slewing Angle	0°	Transmission	Automatic, 4 F+4R Shift
Gradeability	35°	Tyre Size	20.5/70-16
Wheelbase	2300 mm	Tyre Number	4 PCS
Tread	1550 mm	Operating Weight	4500 kg
Mini. Turn Radius	4750 mm	Overall Size	6400 x2550x2450 mm

Standard Accessories

- Four-Wheel Drive
- 0° Slewing Drum+ Bottom Hydraulic Lifting
- Electric Fan inside Cab
- Electric Water Pump

Optional Accessories

- 270° Slewing Drum
- Engine: DONGFENG CUMMINS(4BT3.9-C80, 60 kW)
- Electronic Weighing System
- Centralized Lubricating System
- High Pressure Washing Gun
- Hydraulic Water Pump
- Air-conditioner inside Cab
- Cement Hopper
- Vibrator on Bucket
- Prolonged Chute

