

# 18V, 8A High Efficiency Synchronous Step-down Converter

## Features

- Input Voltage Range: 4.5V to 18V
- Integrated 9.4mΩ and 4.3mΩ MOSFETs
- 0.6V ± 1% Reference Voltage Accuracy
- Output Voltage Adjustable from 0.6V to 5.5V
- Advanced COT Control for Fast Transient Response
- Selectable FPWM or PFM Operation Mode
- Selectable 400kHz, 800kHz and 1.2MHz Switching Frequency
- Selectable Two Level Current Limit Value
- Support Ceramic Output Capacitors
- Programmable Soft-start Time with a Default 1ms Soft-start Time
- Thermal Shutdown
- Output Auto-Discharge in EN Shutdown
- Available in QFN3.5x3.5-18 Package

## Application

- Wireless and Networking Infrastructure
- Server, Storage Equipment
- High End Digital Smart TV
- General Purposes

## Description

The TMI32080 is a high integrated synchronous step-down converter with up to 8A output current capability and input voltage range from 4.5V to 18V. TMI32080 adopts advance COT control mode and has fast transient response performance that could reduce external component count. It integrates very low  $R_{DS(ON)}$  MOSFETs and offers high accurate reference voltage.

TMI32080 offers many selectable functions which supports different application requirements by setting external components flexibly. PFM operation mode provides high efficiency in light load condition and FPWM operation mode has better output voltage regulation accuracy. Selectable switching frequency provides wide application range to trade off efficiency, solution size and cost. Selectable current limit and programmable soft-start time help to control power up inrush current. Robust protections are integrated in TMI32080 including shut down over current protection, output UVP, input UVLO and OTP functions.

TMI32080 is available in QFN3.5x3.5-18 package.

## Typical Application

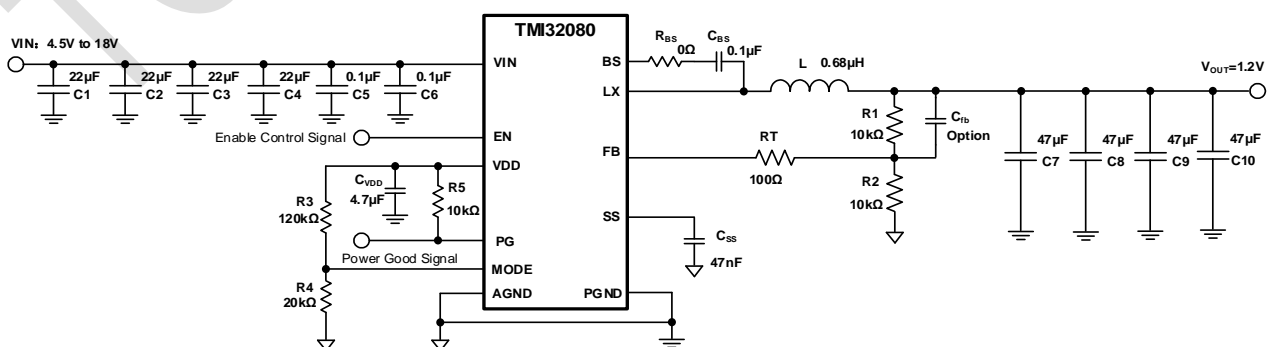
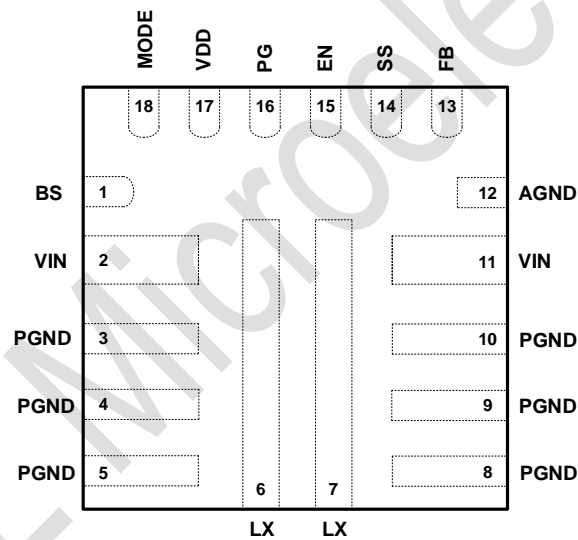

Figure 1. TMI32080 Typical Application Circuit

## Absolute Maximum Ratings (Note 1)

Parameter	Min	Max	Unit
Input Supply Voltage, EN	-0.3	20	V
LX Voltage	-0.3	20	V
LX Voltages (<10ns transient)	-5	22	V
BS Voltage	-0.3	26	V
BS to LX Voltage	-0.3	6	V
All Other Pins	-0.3	6	V
Storage Temperature Range	-65	150	°C
Junction Temperature (Note2)	-40	150	°C
Power Dissipation	-	3.5	W
Lead Temperature (Soldering, 10s)	-	260	°C

## Package



Top View

QFN3.5x3.5-18

Top Marking: T32080XXXX (T32080: Device Code, XXXXX: Inside Code)

## Order Information

Part Number	Package	Top Marking	Quantity/Reel
TMI32080	QFN3.5x3.5-18	T32080 XXXXX	3000

TMI32080 devices are Pb-free and RoHS compliant.

## Pin Functions

Pin	Name	Function
1	BS	Bootstrap. A 0.1 $\mu$ F capacitor connected between LX and BS pins is required to form a floating supply across the high-side switch driver.
2, 11	VIN	Input power supply pin. The decoupling ceramic capacitors should be placed as close as possible from this pin to PGND for better noise rejection.
3, 4, 5, 8, 9, 10	PGND	Power ground pins. PGND and AGND should be connected via as short trace and on only one point.
6, 7	LX	Switching pins. Connect to the power inductor.
12	AGND	Analog ground pin. PGND and AGND should be connected via as short trace and on only one point.
13	FB	Output Voltage feedback input. Connect FB to the center point of the external resistor divider.
14	SS	Soft-start time control pin. Connect a capacitor between SS pin and AGND to set soft-start time. The default internal soft-start time is 1ms with SS pin floating.
15	EN	Drive this pin to a logic-high to enable the IC. Drive to a logic-low to disable the IC and enter micro-power shutdown mode. With floating EN pin, the device is enabled by internal pulling high.
16	PG	Power good indicator output pin.
17	VDD	Internal LDO regulator output. Connect a 4.7 $\mu$ F capacitor to GND for external decoupling.
18	MODE	Function mode set pin for switching frequency, current limit, operation mode in light load condition. Connect this pin to a resistor divider from VDD and AGND to set different MODE options.

## ESD Rating (Note4)

Items	Description	Value	Unit
V <sub>ESD_HBM</sub>	Human Body Model for all pins	$\pm$ 2000	V
V <sub>ESD_CDM</sub>	Charged Device Model for all pins	$\pm$ 500	V

JEDEC specification JS-001

## Recommended Operating Conditions

Items	Description	Min	Max	Unit
Voltage Range	IN	4.5	18	V
T <sub>J</sub>	Operating Junction Temperature	-40	125	$^{\circ}$ C
T <sub>A</sub>	Operating Ambient Temperature	-40	125	$^{\circ}$ C

## Thermal Resistance (Note3)

Items	Description	Value	Unit
$\theta_{JA}$	Junction-to-ambient thermal resistance	29.5	$^{\circ}$ C/W
$\theta_{JC}$	Junction-to-case(top) thermal resistance	17	$^{\circ}$ C/W
$\psi_{JC}$	Junction-to-case(top) characterization parameter	0.5	$^{\circ}$ C/W

## Electrical Characteristics

$V_{IN}=12V$ ,  $V_{OUT}=3.3V$ ,  $T_A = 25^{\circ}C$ ,  $f_{sw}=800kHz$  unless otherwise noted.

Symbol	Parameter	Conditions	Min	Typ	Max	Units
<b>Input Voltage</b>						
$V_{IN}$	Input Voltage Range		4.5		18	V
$V_{UVLO}$	Input Under Voltage Lock Off			4.2		V
$V_{UVLO\_HYS}$	UVLO Hysteresis			650		mV
$I_q$	Quiescent Current	$V_{EN}=2V$ , Non switching		600	800	$\mu A$
$I_{SD}$	Shutdown Current	$V_{IN}=5V$ , $V_{EN}=0V$		7		$\mu A$
<b>Enable</b>						
$V_{EN\_H}$	Enable Input High Voltage			1.225	1.3	V
$V_{EN\_L}$	Enable Input Low Voltage		1.0	1.1		V
$V_{ENHYS}$	EN Hysteresis			0.1		V
$I_{ENp1}$	EN pull-up current	$V_{EN}=1.0V$	0.35	2	2.95	$\mu A$
$I_{ENp2}$		$V_{EN}=1.3V$	3	4.2	5.5	$\mu A$
<b>Feedback Voltage</b>						
$V_{FB}$	FB Voltage		0.594	0.6	0.606	V
<b>LDO Output</b>						
VDD	LDO Output Voltage		4.58	4.7	4.83	V
$I_{LIM\_LDO}$	LDO Output Current Limit		50		200	mA
<b>R<sub>DS(ON)</sub></b>						
$R_{DS(ON)\_H}$	High-Side Switch On Resistance	$T_J=25^{\circ}C$ , $V_{DD}=4.7V$		9.4		m $\Omega$
$R_{DS(ON)\_L}$	Low-Side Switch On Resistance	$T_J=25^{\circ}C$ , $V_{DD}=4.7V$		4.3		m $\Omega$
<b>Current Limit</b>						
$I_{LIM\_1}$	Low-Side Switch Sourcing Current Limit	Valley current		9.6		A
$I_{LIM\_2}$				7.6		
$I_{LIM\_NEG}$	Low-Side Switch Negative Current Limit	Valley current		-4		A
<b>Switching Frequency</b>						
$f_{sw1}$	Switching Frequency	$T_J=25^{\circ}C$ , FPWM		400		kHz
$f_{sw2}$		$T_J=25^{\circ}C$ , FPWM		800		kHz
$f_{sw3}$		$T_J=25^{\circ}C$ , FPWM		1200		kHz
<b>On-Time Timer Control</b>						
$t_{ON\_MIN}$	Minimum On Time	$V_{IN} = 18V$ , $V_{OUT} = 0.6V$ , $f_{sw} = 1200kHz$		50		ns
$t_{OFF\_MIN}$	Minimum Off Time	$T_J=25^{\circ}C$ , $V_{FB}=0.5V$			310	ns
<b>Soft Start</b>						
$t_{ss}$	Soft-Start Time	Internal soft-start time		1.045		ms
$I_{ss}$	Soft-Start Charge Current		4.9	6	7.1	$\mu A$
<b>Output Over-Voltage and Under-Voltage Protections</b>						
$V_{UVP}$	Output UVP Threshold	UVP detect		68		% $V_{FB}$

## Electrical Characteristics

$V_{IN}=12V$ ,  $V_{OUT}=3.3V$ ,  $T_A = 25^{\circ}C$ , unless otherwise noted.

Symbol	Parameter	Conditions	Min	Typ	Max	Units
<b>Power Good</b>						
$V_{PG\_R}$	Power Good Threshold for $V_{FB}$ Rising			93		% $V_{FB}$
$\Delta V_{PG\_R}$	Power Good Hysteresis for $V_{FB}$ Rising			9		% $V_{FB}$
$V_{PG\_F}$	Power Good Threshold for $V_{FB}$ Falling			116		% $V_{FB}$
$\Delta V_{PG\_F}$	Power Good Hysteresis for $V_{FB}$ Falling			9		% $V_{FB}$
<b>Thermal Shutdown</b> (Note 5)						
$T_{SD}$	Thermal Shutdown Temperature			160		$^{\circ}C$
$T_{SDHYS}$	Thermal Shutdown Hysteresis			15		$^{\circ}C$
$T_{SD\_LDO}$	LDO Thermal Shutdown Temperature			171		$^{\circ}C$
$\Delta T_{SD\_LDO}$	LDO Thermal Shutdown Hysteresis			18		$^{\circ}C$

**Note 1:** Absolute Maximum Ratings are those values beyond which the life of a device may be impaired.

**Note 2:**  $T_J$  is calculated from the ambient temperature  $T_A$  and power dissipation  $P_D$  according to the following formula:  $T_J = T_A + P_D \times \theta_{JA}$ .

**Note 3:** Measured on JESD51-7, 4-layer PCB.

**Note 4:** Devices are ESD sensitive. Handling precaution is recommended.

**Note 5:** Guaranteed by design.

## Block Diagram

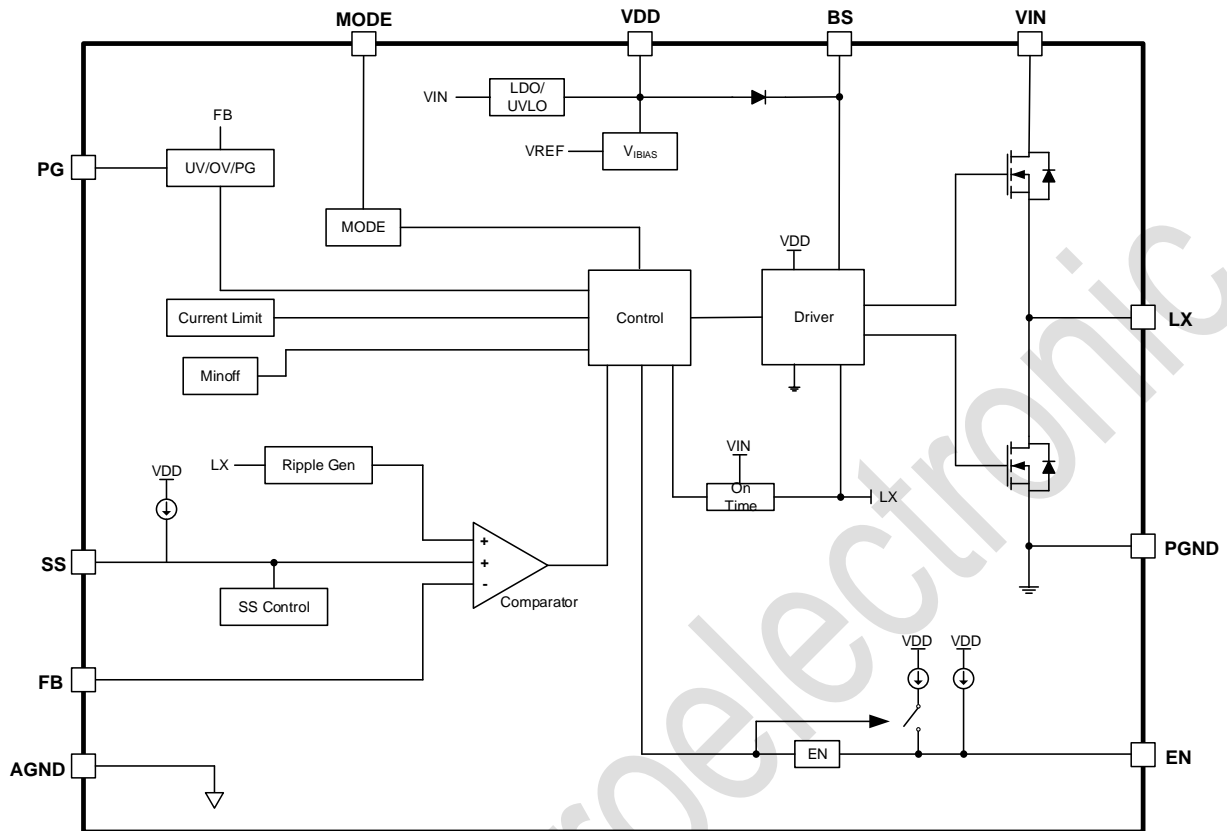

Figure 2. TMI32080 Block Diagram

## Operation Description

### Overview

The TMI32080 is a high integrated synchronous step-down converter which can operate from 4.5V to 18V input voltage, that can deliver up to 8A output current capability. It has 9.4mΩ and 4.3mΩ integrated MOSFETs. The low  $R_{DS(ON)}$  MOSFETs that enable high efficiency, and offers high accurate reference voltage. The TMI32080 adopts advance COT control mode and has fast transient response performance that could reduce external component count, save the PCB size. The control topology provides seamless transition between FPWM operating mode at higher load condition and PFM operation at lighter load condition. At light load, PFM operation allows the TMI32080 to maintain high efficiency.

### Switching Frequency and MODE Selection

TMI32080 has three selectable switching frequencies (FSW) 400kHz, 800kHz and 1200kHz, it gives the flexibility to optimize the design for higher efficiency or smaller size. All these options are configured by choosing the right voltage on the MODE pin. Switching Frequency, current limit and switching mode (PFM or FPWM) are set by a voltage divider from VDD to GND connected to the MODE pin. The two resistors ( $R_{M1}$  and  $R_{M2}$ ) are suggested to use 1% resistors. Selection the operating frequency is a trade-off between efficiency and component size.

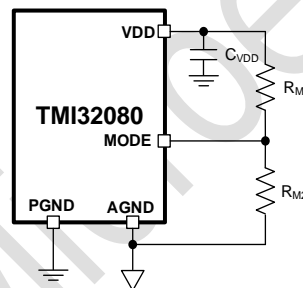

Figure 3. Mode Connection

Table 1. Mode Pin Resistor Settings

Mode	$R_{M1}(k\Omega)$	$R_{M2}(k\Omega)$	Light Load Mode	Current Limit	Switching Frequency(kHz)
1	300	5.1	FPWM	$I_{LIM\_2}$	400
2	200	10	FPWM	$I_{LIM\_1}$	400
3	160	20	FPWM	$I_{LIM\_2}$	800
4	120	20	FPWM	$I_{LIM\_1}$	800
5	200	51	FPWM	$I_{LIM\_2}$	1200
6	180	51	FPWM	$I_{LIM\_1}$	1200
7	150	51	PFM	$I_{LIM\_2}$	400
8	120	51	PFM	$I_{LIM\_1}$	400
9	91	51	PFM	$I_{LIM\_2}$	800
10	82	51	PFM	$I_{LIM\_1}$	800
11	62	51	PFM	$I_{LIM\_2}$	1200
12	51	51	PFM	$I_{LIM\_1}$	1200

## LDO and UVLO

The TMI32080 has a 4.7 V internal LDO that creates bias for all internal circuitry. There is a feature to overdrive this internal LDO with an external voltage on the VDD pin which improves the converter's efficiency. The under voltage lockout (UVLO) circuit monitors the VDD pin voltage to protect the internal circuitry from low input voltages. The device has an internal pull-up current source on the EN pin which can enable the device even with the pin floating.

## SS Time

Soft-start time can be selected by connecting a capacitor to the SS pin. When appropriate voltages are present on the VIN, VCC and EN pins, the TMI32080 will begin switching and initiate a soft-start ramp of the output voltage. An internal soft-start ramp of the TMI32080, it will limit the ramp rate of the output voltage to prevent excessive input current during start-up. If user need set longer ramp time, a capacitor can be placed from the SS pin to ground. The equation for the soft-start time ( $t_{ss}$ ) is shown in the below equation:

$$t_{ss} = \frac{C_{ss} \times V_{REF}}{I_{SS}}$$

where  $I_{SS}=6\mu A, V_{REF}=0.6V$

## Current Limit

The TMI32080 can operate at two different current limits  $I_{LIM\_1}$  and  $I_{LIM\_2}$  to support an output continuous current of 8A and 10A respectively. The device cycle-by-cycle compares the valley current of the inductor against the current limit threshold, hence the output current will be half the ripple current higher than the valley current.

## Output UVP

When the output voltage falls below Output UVP Threshold ( $V_{UVP}$ ), the UVP comparator detects it and shuts down the device to avoid the excessive heat. If the UVP condition remains for a period of time, a soft-start sequence for auto-recovery will be initiated.

## Power Good

The Power Good (PG) pin is an open drain output. The power-good function is activated after soft-start is finished and is controlled by the feedback signal VFB. When the FB pin voltage is between 93% and 107% of the internal reference voltage ( $V_{REF}$ ) the PGOOD is be in high impedance. A pull-up resistor of 10kΩ is recommended to pull it up to VDD. The PGOOD pin is pulled low when the FB pin voltage is lower than VUVP threshold, or, in an event of thermal shutdown or during the soft-start period.

## Startup and Shutdown

If both VIN and EN are higher than their appropriate thresholds, the chip starts switching operation. The reference block starts first, generating stable reference voltage and currents, and then the internal regulator is enabled. The regulator provides stable supply for the remaining circuitries. Three events can shut down the chip: EN low, VIN low and thermal shutdown. In the shutdown procedure, the signaling



path is first blocked to avoid any fault triggering. The  $V_{COMP}$  voltage and the internal supply rail are then pulled down. The floating driver is not subject to this shutdown command.

### Thermal Shutdown-Over Temperature Protection

Thermal shutdown prevents the chip from operating at exceedingly high temperature. When the silicon die temperature exceeds the thermal shutdown threshold value  $160^{\circ}\text{C}$ , the chip stops switching with SS reset to ground and internal discharge switch turns on to quickly discharge the output voltage. During Start up, if the device temperature is higher than  $160^{\circ}\text{C}$  the device does not start switching, The device re-starts switching when the temperature drops more than  $15^{\circ}\text{C}$ , But the MODE setting are not re-loaded again. If the temperature continues to rise and above LDO thermal shutdown threshold  $171^{\circ}\text{C}$  the converter shuts down completely. falls below its lower threshold the chip is enable again.

### Over-Current-Protection and Short Circuits Protection

The TMI32080 has shutdown current limit function. When the inductor current valley value is larger than the valley current limit during low side MOSFET on state, the device enters into shutdown over current protection mode. If the output is short to GND and the output voltage drop until feedback voltage  $V_{FB}$  is below the output under-voltage  $V_{UV}$  threshold which is typically 68% of  $V_{REF}$ , TMI32080 will enters into shutdown mode.

## APPLICATION INFORMATION

### Selecting the Inductor

An inductor is necessary for supplying constant current to the output load while being driven by the switched input voltage, A DC current rating of at least 25% percent higher than the maximum load current is recommended for most applications. Inductance value is related to inductor ripple current value, input voltage, output voltage setting and switching frequency. The inductor value can be derived from the following equation:

$$L = \frac{V_{OUT} \times (V_{IN} - V_{OUT})}{V_{IN} \times \Delta I_L \times f_{OSC}}$$

Where  $\Delta I_L$  is peak-to-peak inductor ripple current. Large value inductors result in lower ripple current and small value inductors result in high ripple current, so inductor value has effect on output voltage ripple value. DC resistance of inductor which has impact on efficiency of DC/DC converter should be taken into account when selecting the inductor. The maximum inductor peak current is:

$$I_{L(MAX)} = I_{LOAD} + \frac{\Delta I_L}{2}$$

Under light load conditions, larger inductance is recommended for improved light load efficiency.

### Selecting the Output Capacitor

The output capacitor is required to maintain the DC output voltage. Ceramic, tantalum, or low ESR electrolytic capacitors are recommended. Low ESR capacitors are preferred to keep the output voltage ripple low. The output voltage ripple can be estimated by:

$$\Delta V_{OUT} = \frac{V_{OUT}}{f_S \times L} \times \left[ 1 - \frac{V_{OUT}}{V_{IN}} \right] \times \left[ R_{ESR} + \frac{1}{8 \times f_S \times C_2} \right]$$

Where L is the inductor value and  $R_{ESR}$  is the equivalent series resistance (ESR) value of the output capacitor. In the case of ceramic capacitors, the impedance at the switching frequency is dominated by the capacitance. The output voltage ripple is mainly caused by the capacitance. For simplification, the output voltage ripple can be estimated by:

$$\Delta V_{OUT} = \frac{V_{OUT}}{8 \times f_S^2 \times L \times C_2} \times \left[ 1 - \frac{V_{OUT}}{V_{IN}} \right]$$

In the case of tantalum or electrolytic capacitors, the ESR dominates the impedance at the switching frequency. For simplification, the output ripple can be approximated to:

$$\Delta V_{OUT} = \frac{V_{OUT}}{f_S \times L} \times \left[ 1 - \frac{V_{OUT}}{V_{IN}} \right] \times R_{ESR}$$

The characteristics of the output capacitor also affect the stability of the regulation system. The TMI32080 can be optimized for a wide range of capacitance and ESR values.

## PCB Layout Guide

PCB layout is very important to achieve stable operation. It is highly recommended to duplicate EVB layout for optimum performance. If change is necessary, please follow these guidelines and take Figure 4 for reference.

- 1) Keep the path of switching current short and minimize the loop area formed by Input capacitor, VIN pin and GND.
- 2) Bypass ceramic capacitors are suggested to be put close to the VIN Pin.
- 3) Ensure all feedback connections are short and direct. Place the feedback resistors as close to the chip as possible.
- 4) VOUT, LX away from sensitive analog areas such as FB.
- 5) Connect VIN, LX, and especially GND respectively to a large copper area to cool the chip to improve thermal performance and long-term reliability.

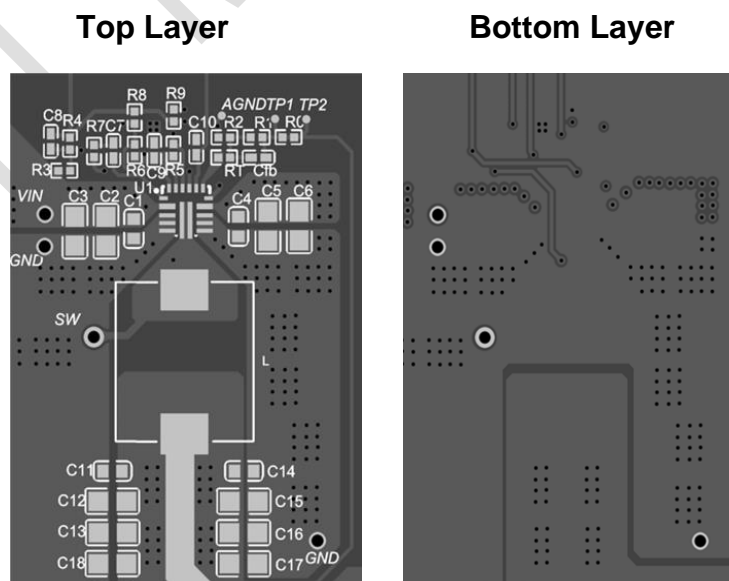
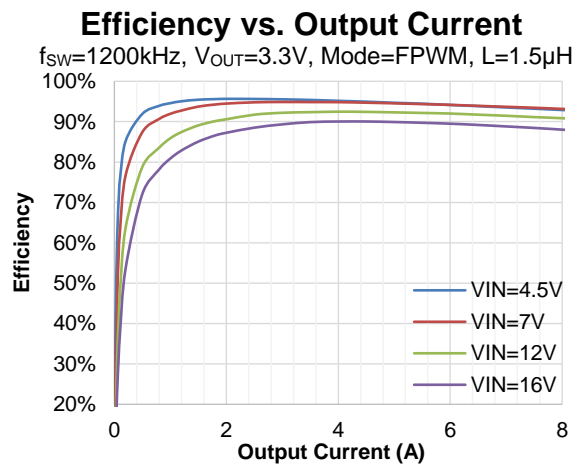
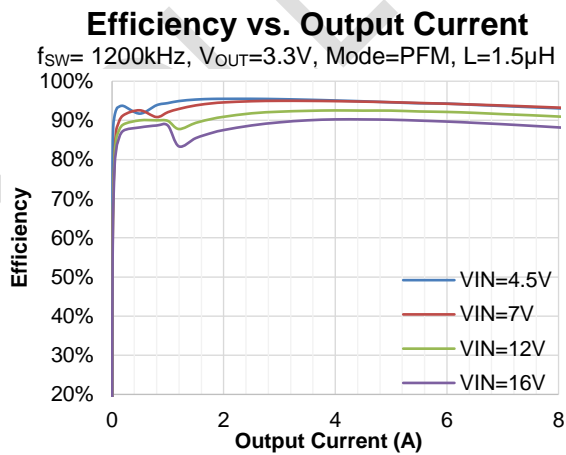
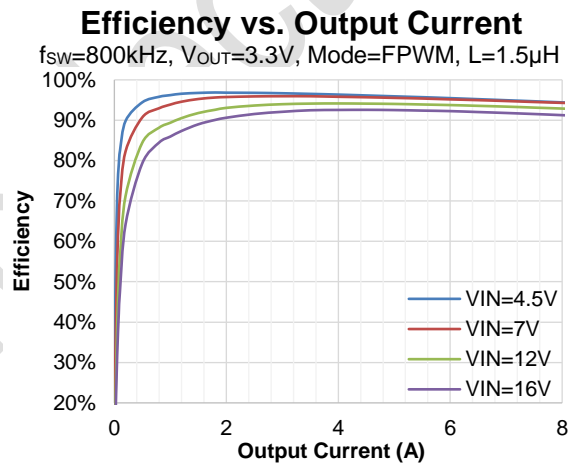
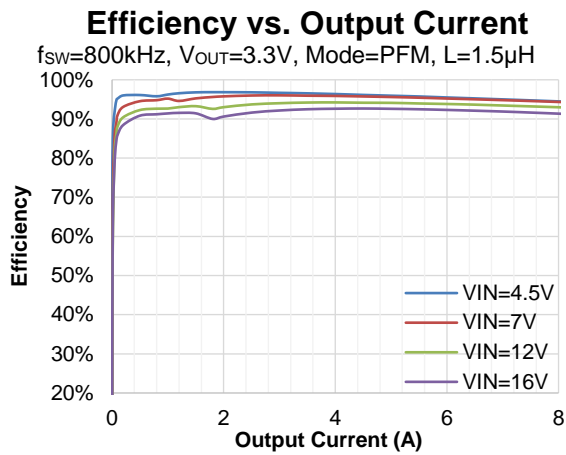
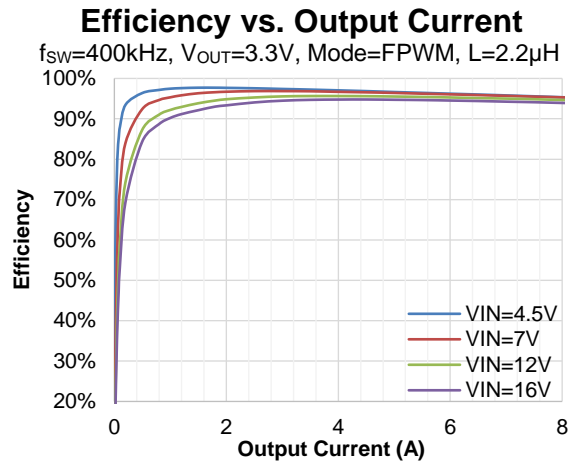
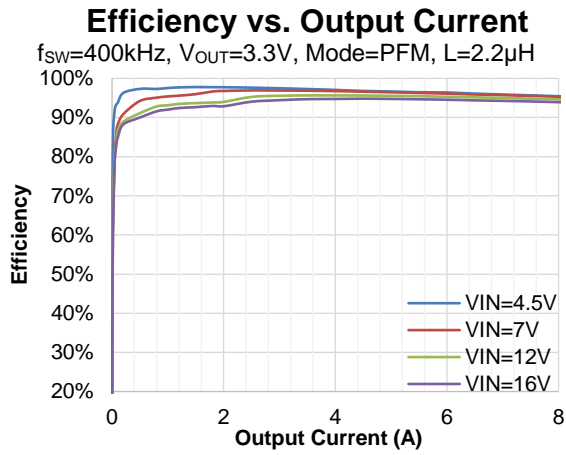
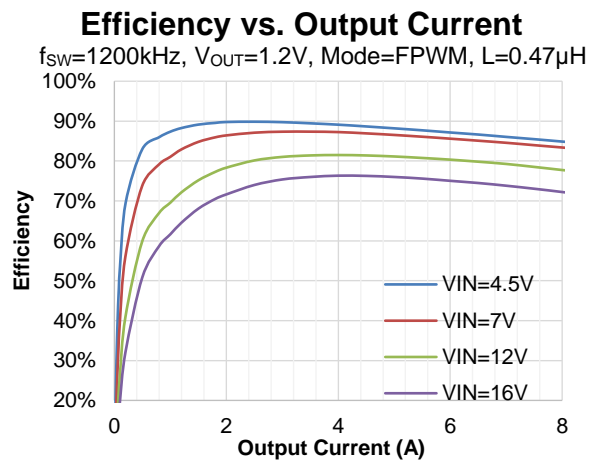
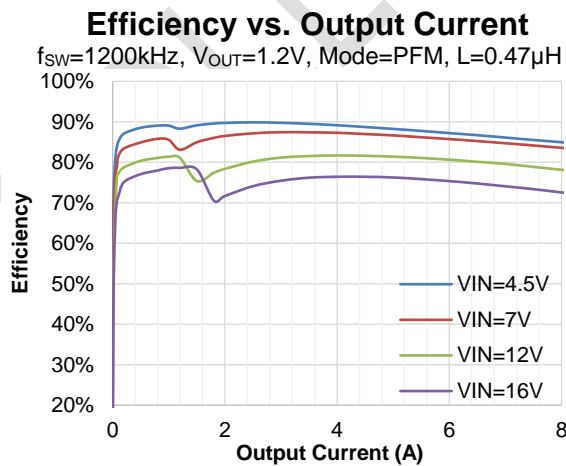
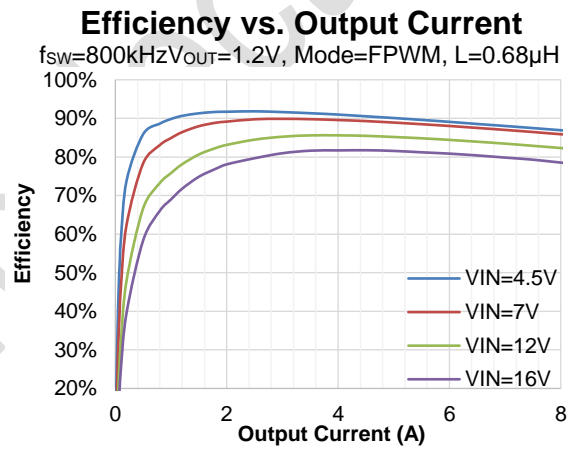
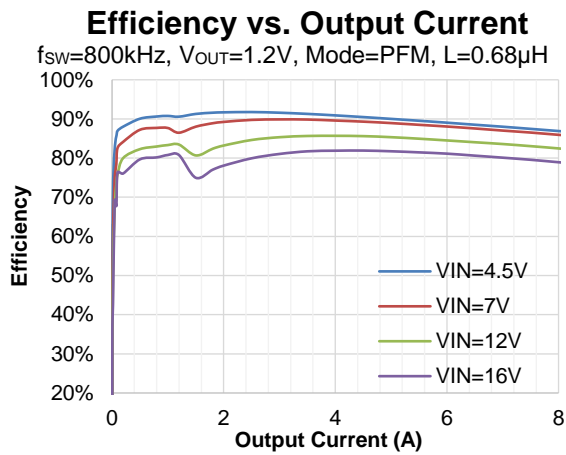
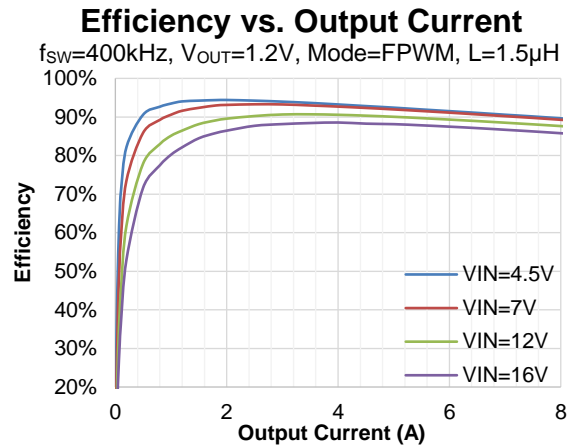
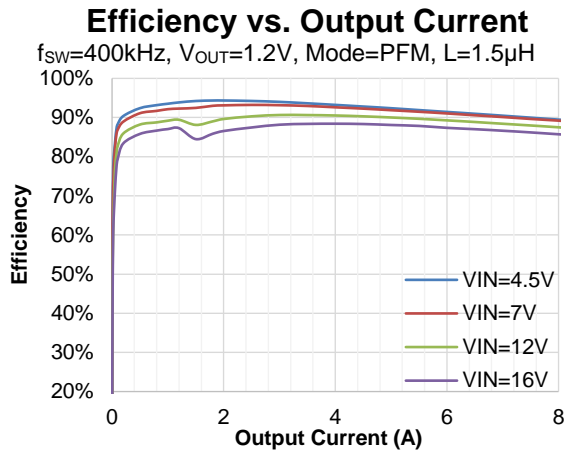

Figure 4. Sample of PCB Layout

### Typical Performance Characteristics(continued)



## Typical Performance Characteristics(continued)



Typical Performance Characteristics(continued)

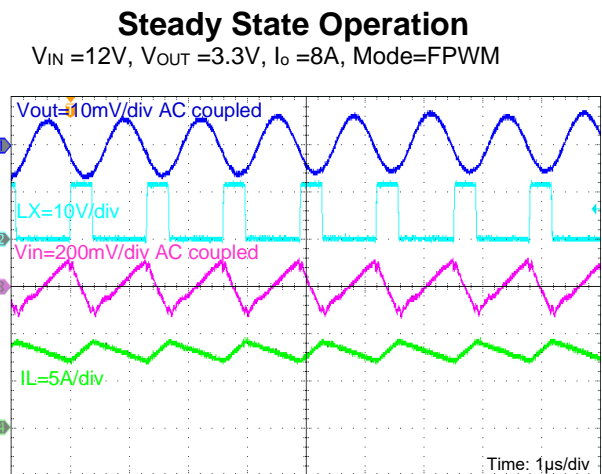
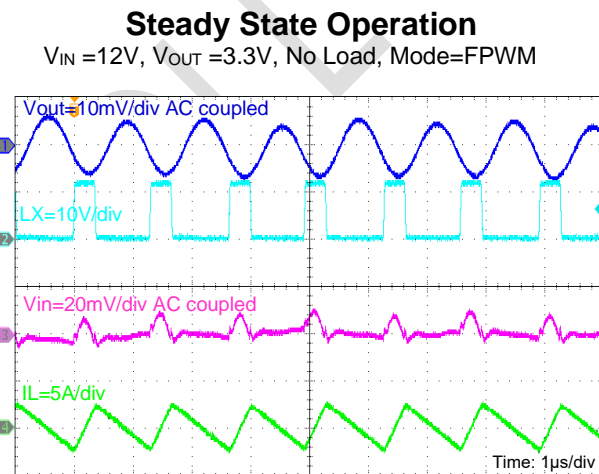
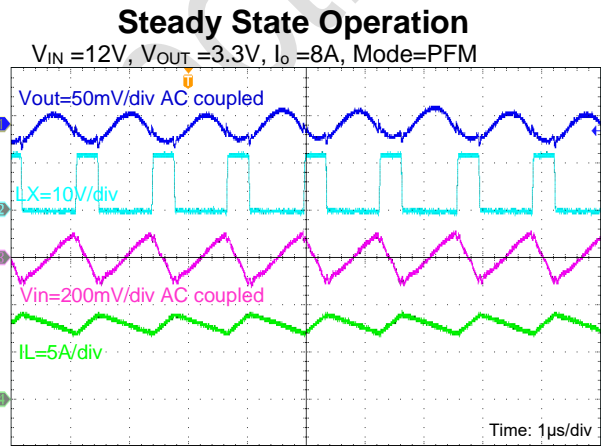
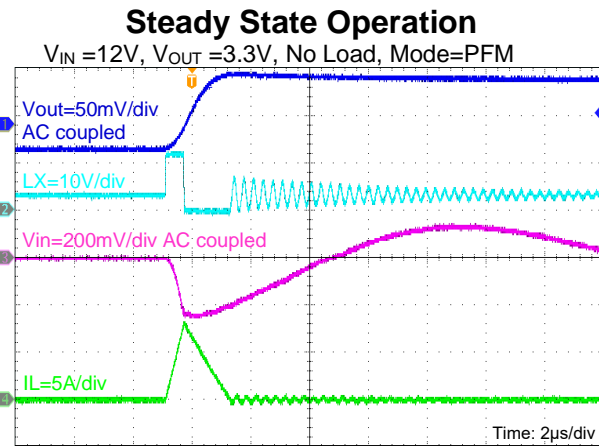
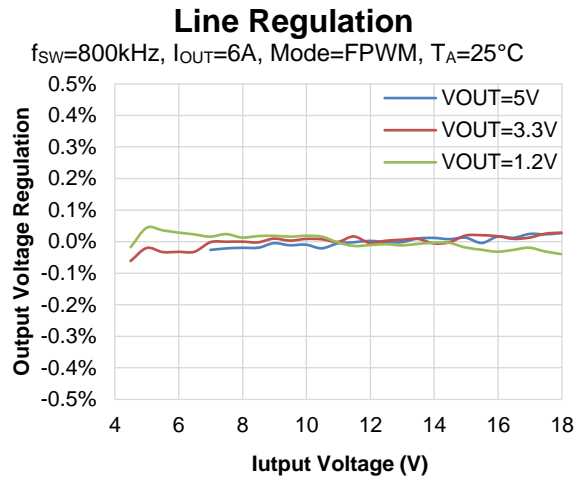
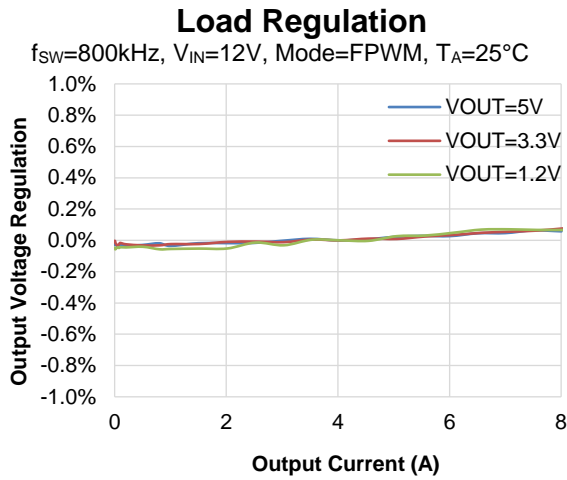

Typical Performance Characteristics(continued)

Load Transient

$V_{IN} = 12V, V_{OUT} = 3.3V, I_o = 0A \text{ to } 4A, \text{ Mode} = \text{PFM}$

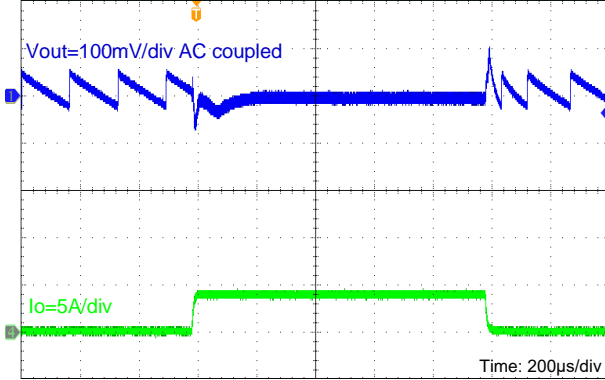

Load Transient

$V_{IN} = 12V, V_{OUT} = 3.3V, I_o = 4A \text{ to } 8A, \text{ Mode} = \text{PFM}$

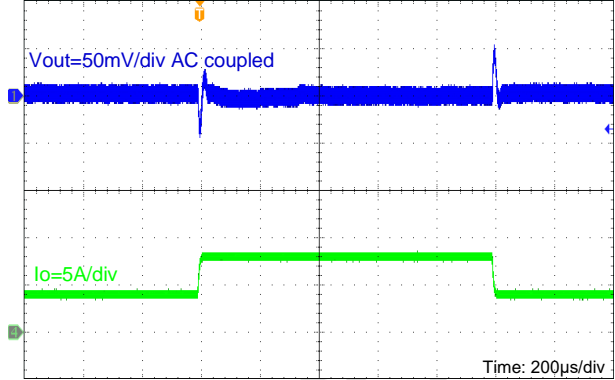

Load Transient

$V_{IN} = 12V, V_{OUT} = 3.3V, I_o = 0A \text{ to } 4A, \text{ Mode} = \text{FPWM}$

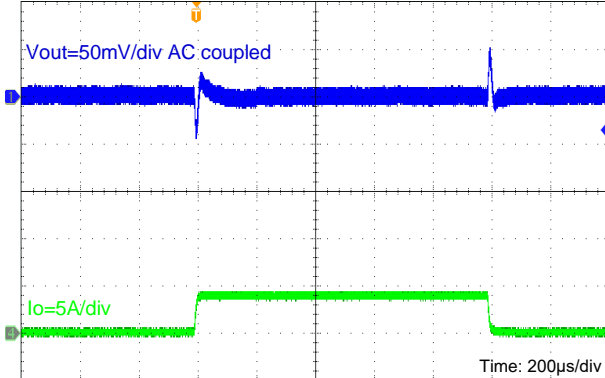

Load Transient

$V_{IN} = 12V, V_{OUT} = 3.3V, I_o = 4A \text{ to } 8A, \text{ Mode} = \text{FPWM}$

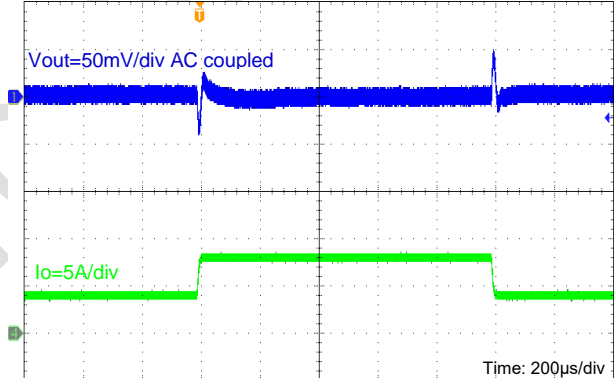

Output Short Entry

$V_{IN} = 12V, V_{OUT} = 3.3V, I_o = 8A$

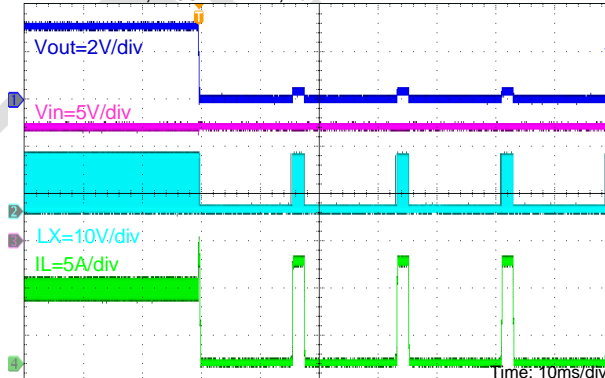

Output Short Recovery

$V_{IN} = 12V, V_{OUT} = 3.3V, I_o = 8A$

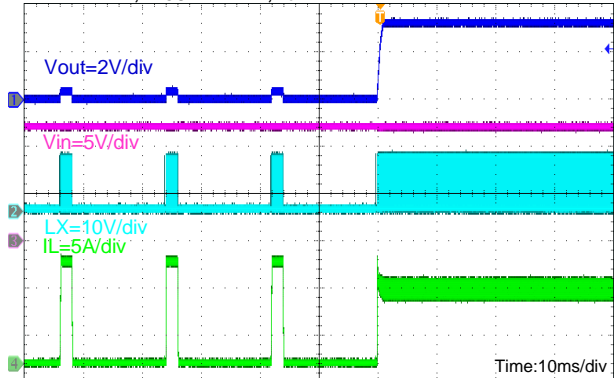

Typical Performance Characteristics(continued)

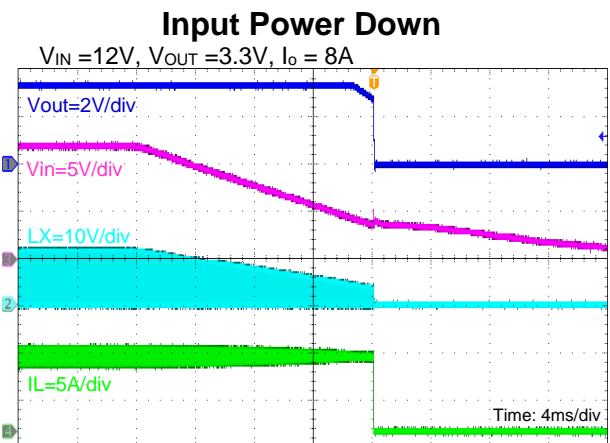
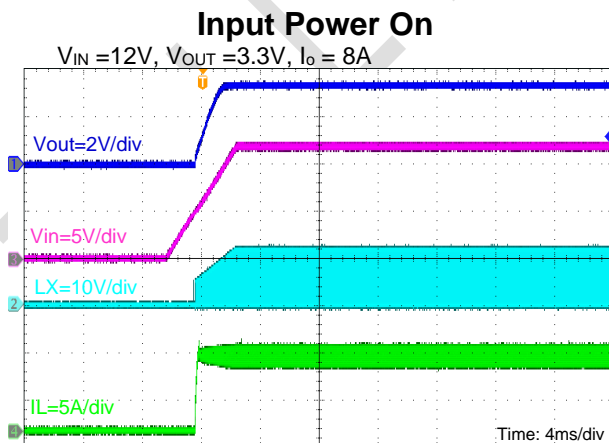
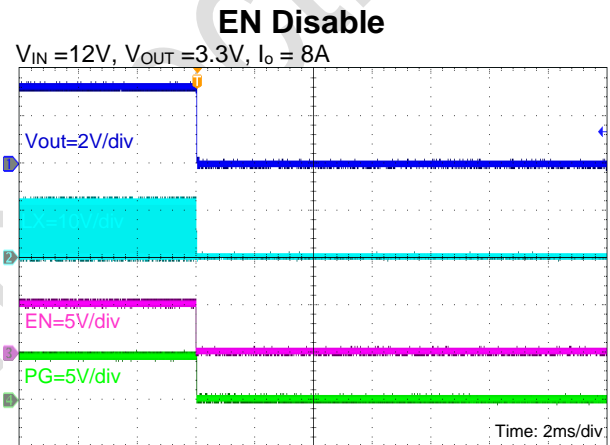
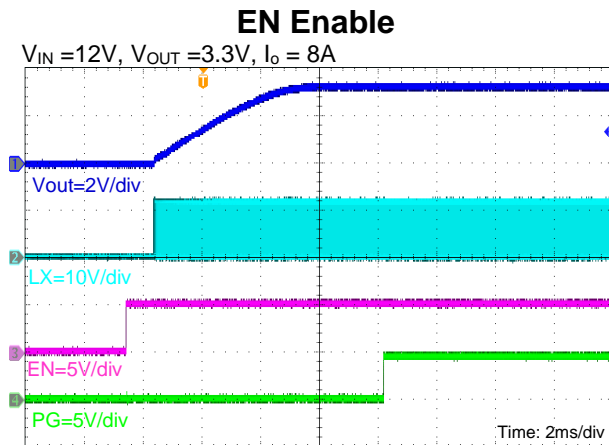
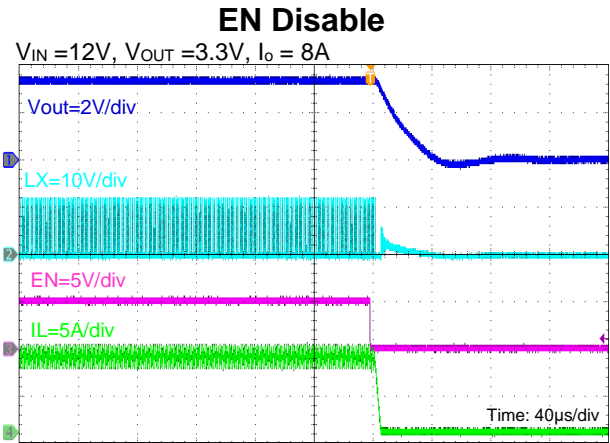
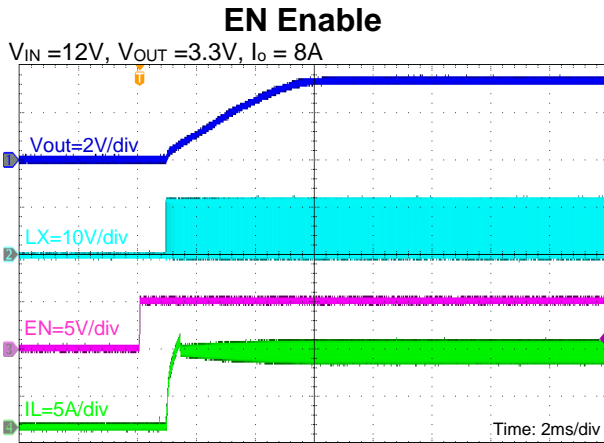

## Typical Performance Characteristics(continued)

### Input Power On

$V_{IN} = 12V$ ,  $V_{OUT} = 3.3V$ ,  $I_o = 8A$

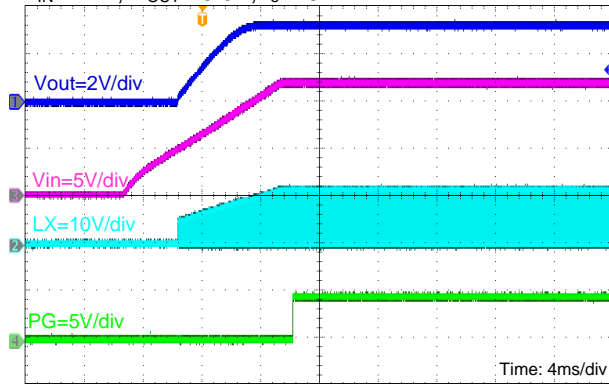

### Input Power Down

$V_{IN} = 12V$ ,  $V_{OUT} = 3.3V$ ,  $I_o = 8A$

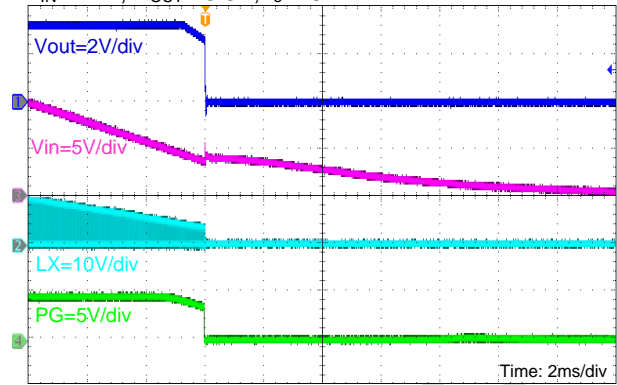



## Package Information

### QFN3.5x3.5-18

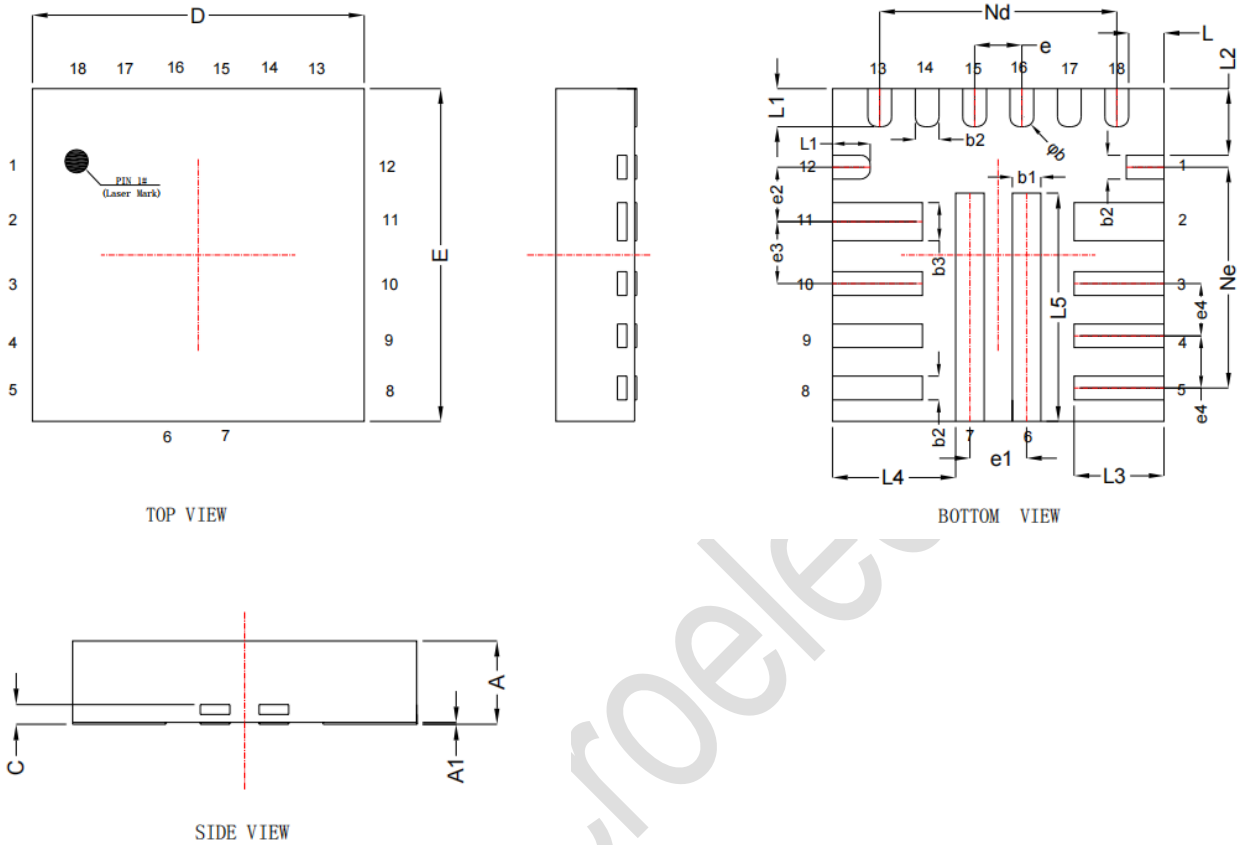

Unit: mm

Symbol	Dimensions In Millimeters			Symbol	Dimensions In Millimeters		
	Min	Nom	Max		Min	Nom	Max
A	0.8	0.9	1	e1	0.6 BSC		
A1	0.00	0.02	0.05	e2	0.575 BSC		
$\phi b$	0.15	0.20	0.25	e3	0.65 BSC		
b1	0.25	0.30	0.35	e4	0.55 BSC		
b2	0.20	0.25	0.30	E	3.40	3.50	3.60
b3	0.35	0.40	0.45	L	0.375 REF		
c	0.203 REF			L1	0.35	0.40	0.45
D	3.40	3.50	3.60	L2	0.700 REF		
Nd	2.50 BSC			L3	0.90	0.95	1.00
Ne	2.325 BSC			L4	1.300 REF		
e	0.50 BSC			L5	2.35	2.40	2.45

#### Note:

1) All dimensions are in millimeters.

## Tape And Reel Informaion

### TAPE DIMENSIONS: QFN3.5x3.5-18

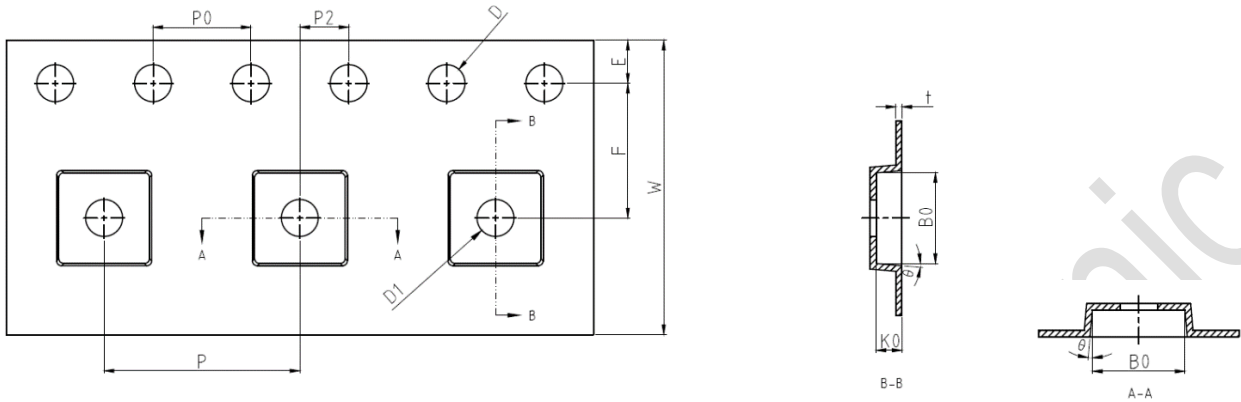

Symbol	P	P0	P2	D	A	D1	B
Dimension (mm)	8.00±0.10	4.00±0.10	2.00±0.05	1.5 <sup>+0.10</sup> <sub>0</sub>	3.70±0.10	1.50MIN	3.70±0.10
Symbol	E	F	W	K0	B0	t	θ
Dimension (mm)	1.75±0.10	5.50±0.05	12 <sup>+0.30</sup> <sub>-0.10</sub>	1.05±0.10	3.70±0.10	0.25±0.03	5° TYP

### REEL DIMENSIONS: QFN3.5x3.5-18

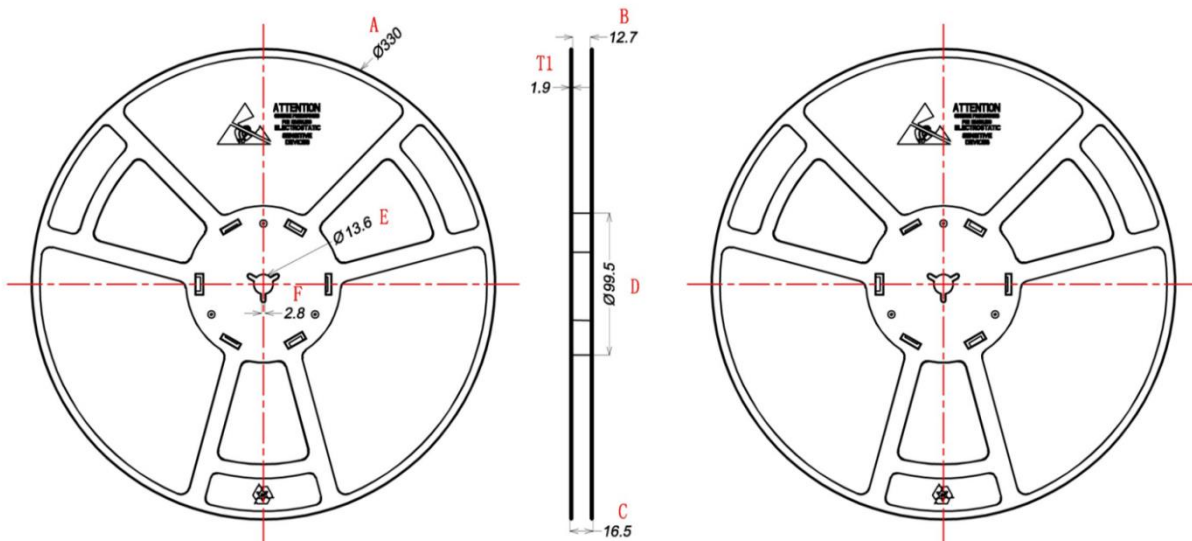

Unit: mm

A	B	C	D	E	F	T1
∅ 330±1	12.7±0.5	16.5±0.3	∅ 99.5±0.5	∅ 13.6±0.2	2.8±0.2	1.9±0.2

#### Note:

- 1) All Dimensions are in Millimeter
- 2) Quantity of Units per Reel is 3000
- 3) MSL level is level 3.

## Important Notification

This document only provides product information. TOLL Microelectronic Inc. reserves the right to make corrections, modifications, enhancements, improvements, and other changes to its products and to discontinue any product without notice at any time.

TOLL Microelectronic Inc. cannot assume responsibility for use of any circuitry other than circuitry entirely embodied in a TOLL Microelectronic Inc. product. No circuit patent licenses are implied.

All rights are reserved by TOLL Microelectronic Inc.  
[http:// www.toll-semi.com](http://www.toll-semi.com)