

Swing - Out Ball Valves

SWB 320 Series & SWB 310 Series



SWB 320 Series

Specification

Pressure Rating up to 3000 psig (206 bar) at 100°F (37°C) / Temperature Range from -20°F (-28°C) to 450°F (232°C)

Testing

Each valve is tested with nitrogen at 1000 psig (69 bar) to maximum allowable leak rate of 0.1 SCCM. Hydrostatic shell test is performed at 1.5 times the working pressure.

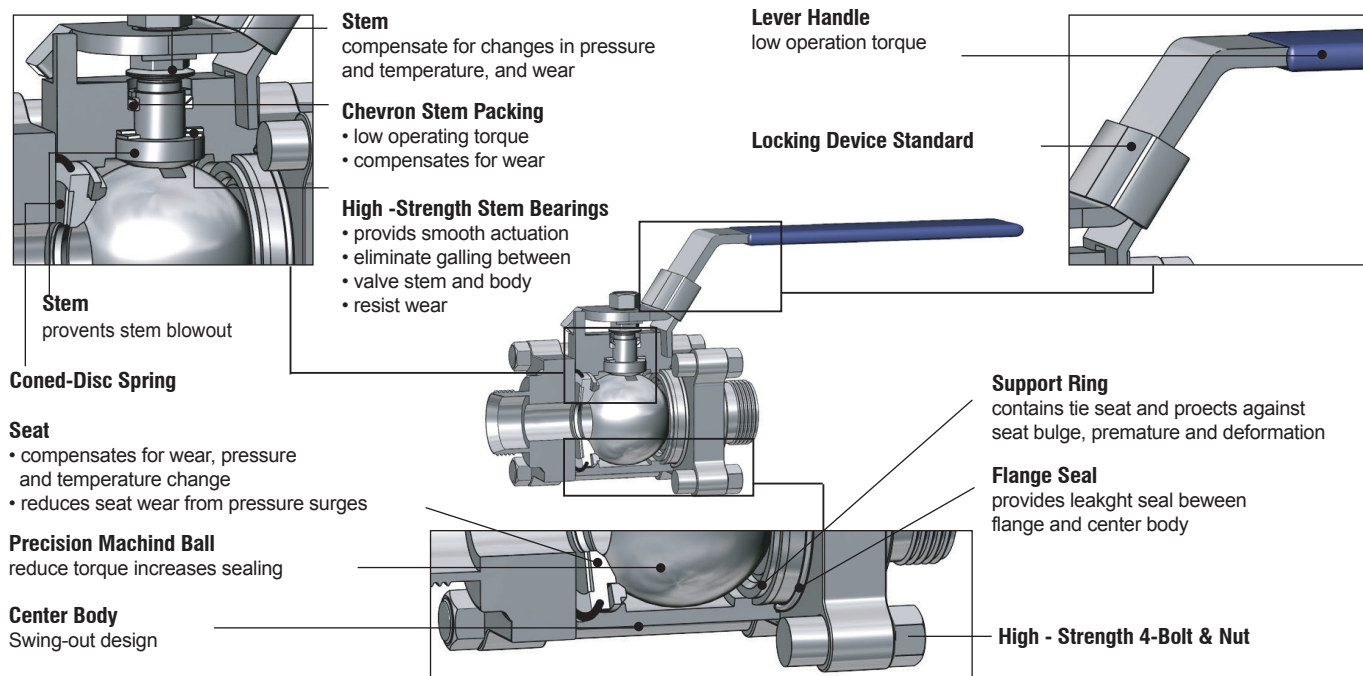

Materials of Construction

Component	Valve Body Materials		Q'TY
	Material / ASTM Specification		
1	Body	CF8M / A351	1
2	Ball	CF8M / A351	1
3	Support Ring	SS316 / A276	2
4	Seats	Reinforced PTFE	2
5	Seat Spring	Strain Hardned 316 SS / A240	2
6	Flange Seal	PTFE	2
7	Flange	CF8M / A351	2
8	Stem	SS316 / A276	1
9	Stem Bearing	PEEK	1
10	Lower Packing	Reinforced PTFE	1
11	Upper Packing	Reinforced PTFE	1
12	Packing Support	SS316 / A276	1
13	Packing Gland	SS316 / A276	1
14	Stem Spring	Stainless Steel	3
15	Packing Nut	Stainless Steel	2
16	Handle	Stainless Steel	1
17	Locking Device	Stainless Steel	1
18	Flange Bolt	A193/B8M	4
19	Flange Nut	A194/8M	4

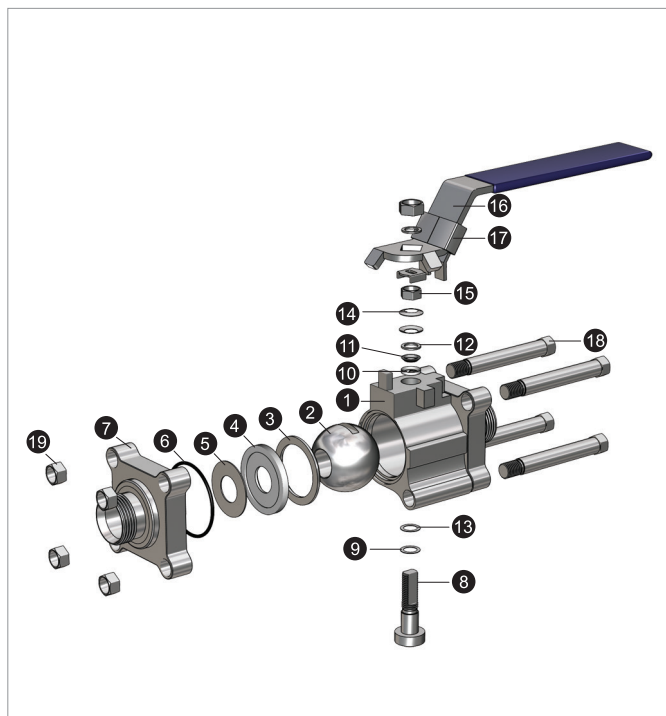

Instrumentation Ball Valves

Pressure/Temperature Rating

Reinforced PTFE Seats (R-PTFE) : Standard

Series	Pressure - Temperature Rating	
	Temperature °C (°F)	Working Pressure psig (bar)
SWB 320	-20 to 100 (-28 to 37)	2200 (151)
	150 (65)	1850 (127)
	200 (93)	1500 (103)
	250 (121)	1150 (79.2)
	300 (148)	800 (55.1)
	350 (176)	560 (38.5)
	400 (204)	330 (22.7)
	450 (232)	100 (6.8)

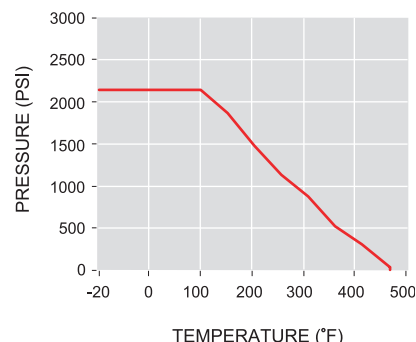

Carbon / Glass PTFE Seats : option

Series	Pressure - Temperature Rating	
	Temperature °C (°F)	Working Pressure psig (bar)
SWB 320	-20 to 100 (-28 to 37)	2500 (172)
	150 (65)	2430 (167)
	200 (93)	1870 (128)
	250 (121)	1620 (111)
	300 (148)	1240 (85.4)
	350 (176)	860 (59.2)
	400 (204)	480 (33.0)
	450 (232)	100 (6.8)

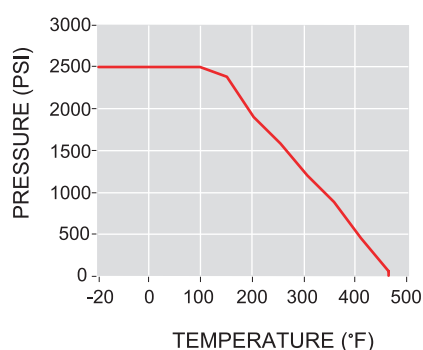

To order option item, add C to the end of ordering number.

PEEK Seats : option

Series	Pressure - Temperature Rating	
	Temperature °C (°F)	Working Pressure psig (bar)
SWB 320	-20 to 100 (-28 to 37)	3000 (206)
	150 (65)	2420 (166)
	200 (93)	1870 (128)
	250 (121)	1770 (121)
	300 (148)	1600 (110)
	350 (176)	1430 (98.5)
	400 (204)	1260 (86.8)
	450 (232)	800 (55.1)

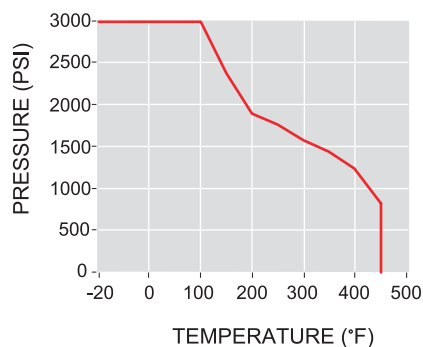

To order option item, add P to the end of ordering number.

Virgin PTFE Seats : option

Series	Pressure - Temperature Rating	
	Temperature °C (°F)	Working Pressure psig (bar)
SWB 320	-20 to 100 (-28 to 37)	1500 (103)
	150 (65)	1500 (103)
	200 (93)	1500 (103)
	250 (121)	1150 (79.2)
	300 (148)	800 (55.1)
	350 (176)	560 (38.5)
	400 (204)	330 (22.7)
	450 (232)	100 (6.8)

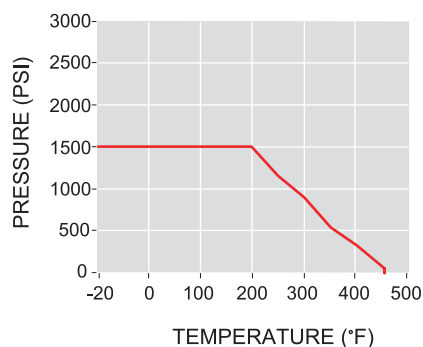

To order option item, add V to the end of ordering number.

Table of Dimensions

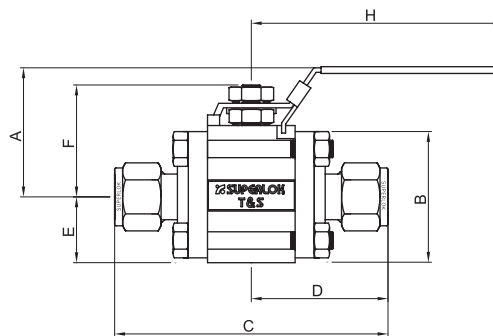
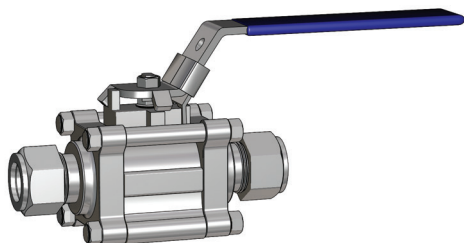

SUPERLOK Tube End Connection

Part Number	Orifice in.(mm)	Cv	End Connection	Dimension							
				A	B	C	D	E	F	H	
SWB3201	S4	0.188 (4.8)	1.2	1/4 " Superlok	47.7	33.0	80.8	40.40	16.75	31.8	57.2
	S6	0.281 (7.1)	3.8	3/8 " Superlok							
	S6M	0.188 (4.8)	1.2	6mm Superlok							
	S8M	0.250 (6.4)	2.5	8mm Superlok							
SWB3202	S10M	0.281 (7.1)	3.8	10mm Superlok	64.8	44.5	103.8	51.90	22.25	44.2	111.0
	S8	0.411 (10.4)	7.5	1/2 " Superlok							
	S12	0.516 (13.1)	13.6	3/4 " Superlok							
SWB3203	S12M	0.411 (10.4)	7.5	12mm Superlok	79.0	62.0	136.7	68.35	31.0	61.9	149.4
	S16	0.875 (22.2)	40.0	1 " Superlok							
SWB3204	S25M					25mm Superlok					
SWB3204	S24	1.250 (31.8)	100	1-1/2 " Superlok	102.0	77.7	192.6	96.3	38.9	79.8	232.0
SWB3205	S32	1.500 (38.1)	130	2 " Superlok	106.0	88.1	252.0	126.0	44.2	85.3	232.0

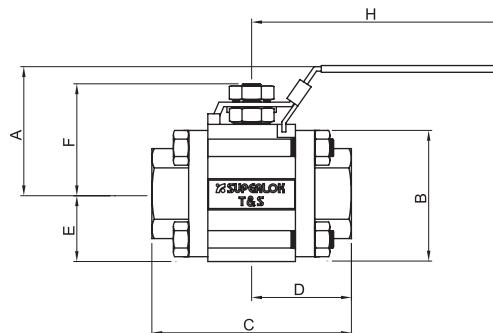
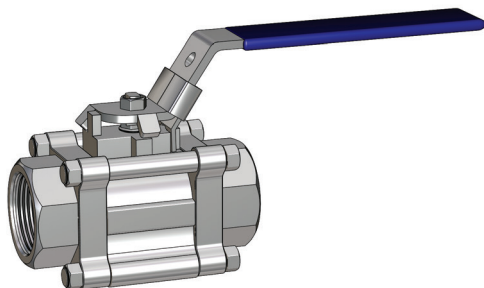

Female Pipe Thread End Connections

Part Number	Orifice in.(mm)	Cv	End Connection	Dimension							
				A	B	C	D	E	F	H	
SWB3201	F2N	0.281 (7.1)	3.8	1/8 " Female NPT	47.7	33.0	55.4	27.70	16.75	31.8	57.2
	F4N			1/4 " Female NPT							
	F4R			1/4 " Female PT							
SWB3202	F6N	0.516 (13.1)	12.0	3/8 " Female NPT	64.8	44.5	68.9	34.45	22.25	44.2	111.0
	F8N			1/2 " Female NPT							
	F8R			1/2 " Female PT							
SWB3203	F12N	0.875 (22.2)	40.0	3/4 " Female NPT	79.0	62.0	92.0	46.0	31.0	61.9	149.4
	F16N			1 " Female NPT							
	F12R			3/4 " Female PT							
	F16R			1 " Female PT							
SWB3204	F20N	1.250 (31.8)	90	1-1/4 " Female NPT	102.0	77.7	112.2	55.6	38.9	79.8	232.0
	F24N		100	1-1/2 " Female NPT							
	F24R			1-1/2 " Female PT							
SWB3205	F32N	1.500 (38.1)	130	2 " Female NPT	106.0	88.1	125.4	62.7	44.2	85.3	232.0
	F32R			2 " Female PT							

• All dimensions in millimeters unless specified as "inch". Dimension are for reference only, subject to change.

Table of Dimensions

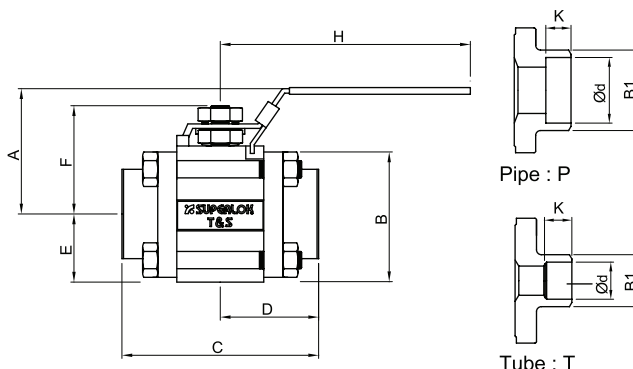
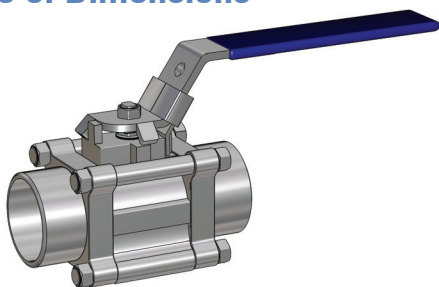

Socket weld end connections

Part Number	Orifice in.(mm)	Cv	End Connection	Dimension														
				ød	B1	A	B	C	D	E	F	H	K					
SWB3201	SW4T	0.188 (4.8)	1.2	1/4 " Socket Weld	6.50	13.70	47.7	33.0	55.4	27.70	16.75	31.8	57.2	7.1				
	SW6T	0.281 (7.1)	3.8	3/8 " Socket Weld	9.70	17.10								7.9				
SWB3202	SW8T	0.411 (10.4)	7.5	1/2 " Socket Weld	12.90	21.30	64.8	44.5	68.9	34.45	22.25	44.2	111.0	9.7				
	SW12T	0.516 (13.1)	13.6	3/4 " Socket Weld	19.20	26.70								11.2				
SWB3203	SW8P	0.516 (13.1)	15.0	1/2 " Socket Weld	21.80	31.20	79.0	62.0	92.0	46.00	31.00	61.9	149.4	9.7				
	SW16T		40.0	1 " Socket Weld	25.65	33.40								16.0				
	SW12P	0.875 (22.2)	36.0	3/4 " Socket Weld	27.20	42.16								12.7				
SWB3204	SW16P		42.0	1 " Socket Weld	33.90	45.30	102.0	77.7	112.2	55.6	38.9	79.8	232.0	15.7				
	SW20T	1.125 (28.6)	80.0	1-1/4 " Socket Weld	32.00	42.20								19.1				
	SW24T		100.0	1-1/2 " Socket Weld	38.30													
	SW20P	1.250 (31.8)	90.0	1-1/4 " Socket Weld	42.70	62.20								114.4	57.2	12.7		
SWB3205	SW24P		100.0	1-1/2 " Socket Weld	48.80		106.0	88.1	116.4	58.2	44.2	85.3	232.0	19.1				
	SW32T	1.500 (38.1)	130.0	2 " Socket Weld	51.10	70.10								86.8	125.4	62.7	43.2	16.0
	SW32P			2 " Socket Weld	61.20	75.10												

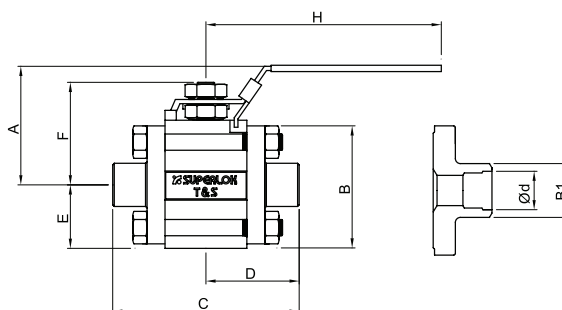
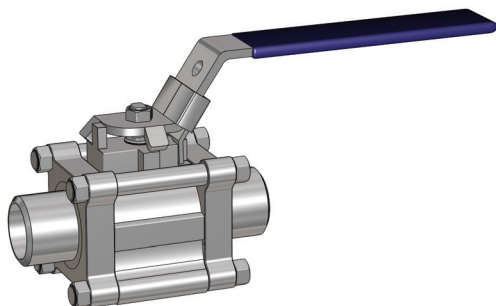

Butt weld end connections

Part Number	Schedule	Orifice in.(mm)	Cv	End Connection	Dimension								
					ød	B1	A	B	C	D	E	F	H
SWB3201	BW4P	0.188 (4.8)	1.2	1/4 " Butt Weld	10.40	13.70	47.7	33.0	52.4	26.20	16.75	31.8	57.2
SWB3202	BW8P	0.516 (13.1)	15.0	1/2 " Butt Weld	17.10	21.30	64.8	44.5	68.9	34.45	22.25	44.2	111.0
SWB3203	BW12P	0.875 (22.2)	36.0	3/4 " Butt Weld	22.45	26.67	79.0	62.0	92.0	46.00	31.0	61.9	149.4
SWB3203	BW16P		40.0	1 " Butt Weld	27.90	33.40			88.9	44.45			
SWB3201	BW4P	0.188 (4.8)	1.2	1/4 " Butt Weld	9.20	13.70	47.7	33.0	52.4	26.20	16.75	31.8	57.2
SWB3202	BW8P	0.516 (13.1)	15.0	1/2 " Butt Weld	15.80	21.30	64.8	44.5	68.9	34.45	22.25	44.2	111.0
SWB3203	BW12P	0.875 (22.2)	36.0	3/4 " Butt Weld	20.93	26.67	47.7	62.0	92.0	46.00	31.0	61.9	149.4
SWB3203	BW16P		40.0	1 " Butt Weld	26.60	33.40			88.9	44.45			
SWB3201	BW4P	0.188 (4.8)	1.2	1/4 " Butt Weld	7.70	13.70	79.0	33.0	52.4	26.20	16.75	31.8	57.2
SWB3201	BW6P	0.281 (7.1)	3.8	3/8 " Butt Weld	10.70	17.10	64.8	44.5	68.9	34.45	22.25	44.2	111.0
SWB3202	BW8P	0.411 (10.4)	7.5	1/2 " Butt Weld	13.90	21.30							
SWB3202	BW12P	0.516 (13.1)	13.6	3/4 " Butt Weld	18.80	26.70	79.0	62.0	88.9	44.45	31.00	61.9	149.4
SWB3203	BW16P	0.875 (22.2)	40.0	1 " Butt Weld	23.90	33.40							
SWB3204	BW24P	1.125 (28.6)	100	1-1/2 " Butt Weld	42.70	48.30	102.0	77.7	113.2	56.60	38.90	79.8	232.0
SWB3205	BW32P	1.500 (38.1)	130	2 " Butt Weld	54.80	60.30	106.0	88.1	121.4	60.70	44.20	85.3	
SWB3204	BW24P	1.125 (28.6)	100	1-1/2 " Butt Weld	40.90	48.30	102.0	77.7	113.2	56.60	38.90	79.8	232.0
SWB3205	BW32P	1.500 (38.1)	130	2 " Butt Weld	52.50	60.30	106.0	88.1	123.4	61.70	44.20	85.3	
SWB3204	BW24P	1.125 (28.6)	100	1-1/2 " Butt Weld	38.10	48.30	102.0	77.7	115.8	57.90	38.90	79.8	232.0
SWB3205	BW32P	1.500 (38.1)	130	2 " Butt Weld	49.30	60.30	106.0	88.1	129.6	64.80	44.20	85.3	

* All dimensions in millimeters unless specified as "inch". Dimension are for reference only, subject to change.

SWB 310 Series

Specification

Pressure Rating up to 1000 psig (69 bar) at 100°F (37°C)
 Temperature Range from -20°F (-28°C) to 450°F (232°C)

Testing

Each valve is tested with nitrogen at 1000 psig (69 bar) to maximum allowable leak rate of 0.1 SCCM.
 Hydrostatic shell test is performed at 1.5 times the working pressure.

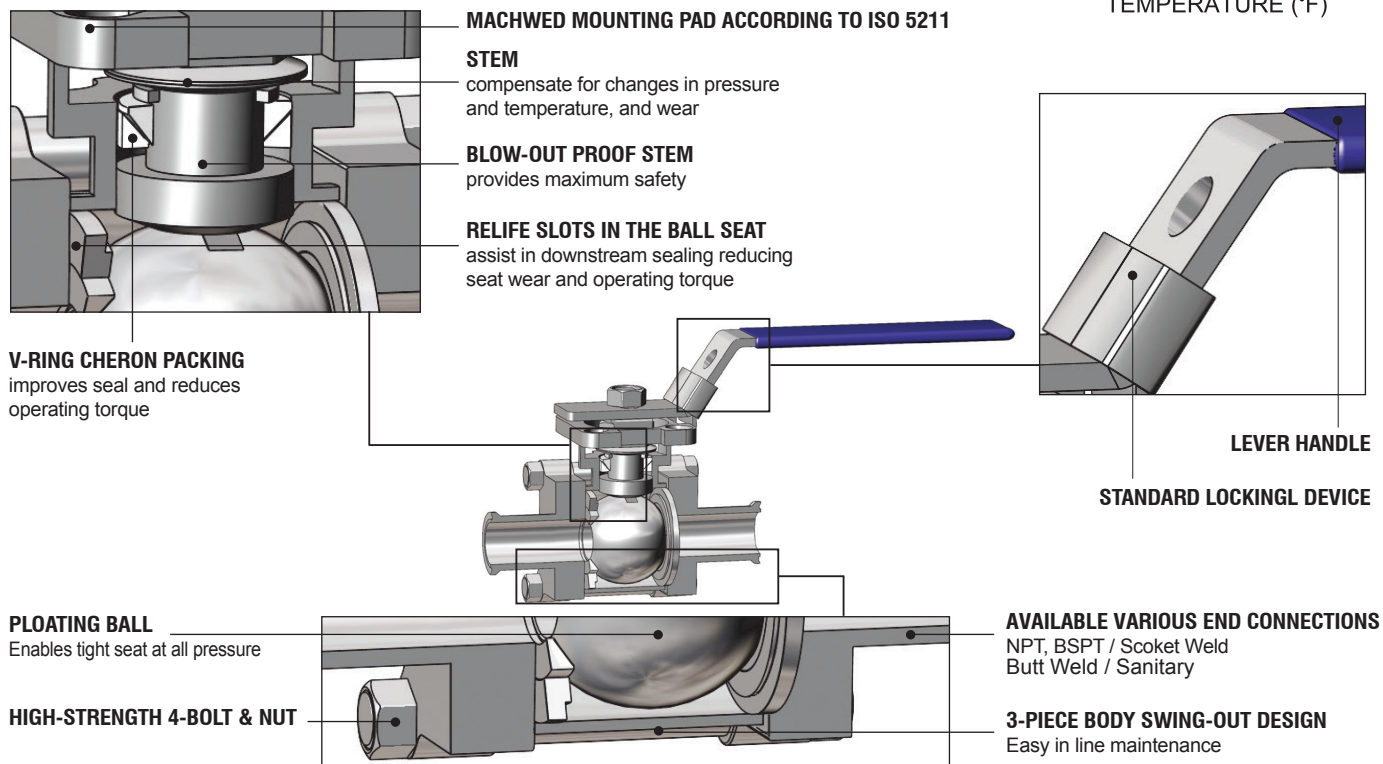
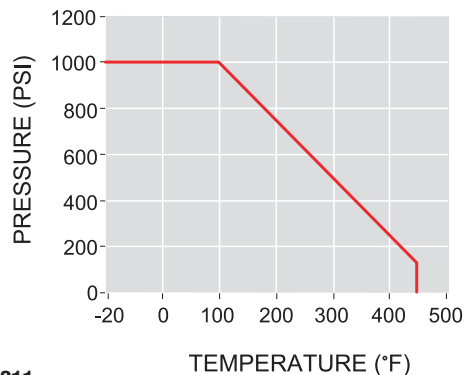

Materials of Construction

Component	Materials	Q'TY	
1	Body	ASTM A351GR/CF8M	1
2	End Cap	ASTM A351GR/CF8M	2
3	Ball	SS 316	1
4	Ball Seal	PTFE	2
5	Flange Seal	PTFE	2
6	Stem	SS316	1
7	Stem Seal	PTFE	1
8	Upper/Lower Packing	PTFE	1
9	Packing Gland	SS304	1
10	Handle Nut	STRAIN HARDNED 316	1
11	Disc Spring	SS304	2
12	Stem Nut	SS304	1
13	Handle	SS304	1
14	Locking Device	SS304	1
15	Stem Nut Lock	SS304	1
16	Flange Bolt	SS304	4
17	Flange Nut	SS304	4

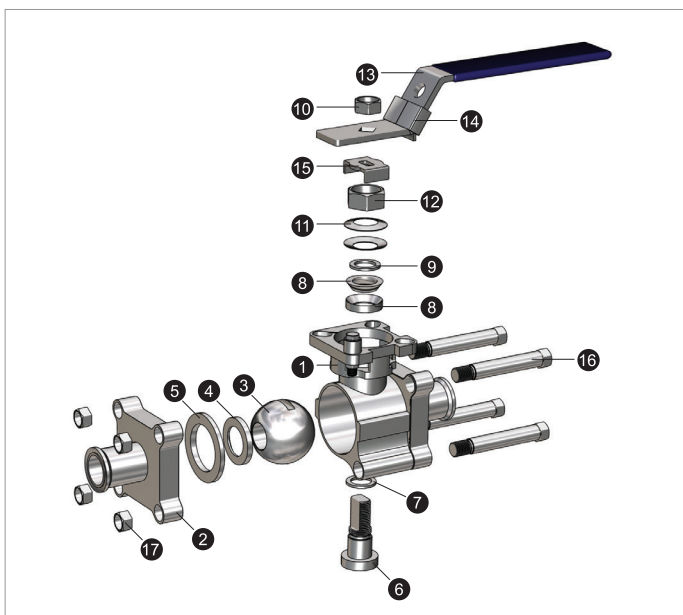
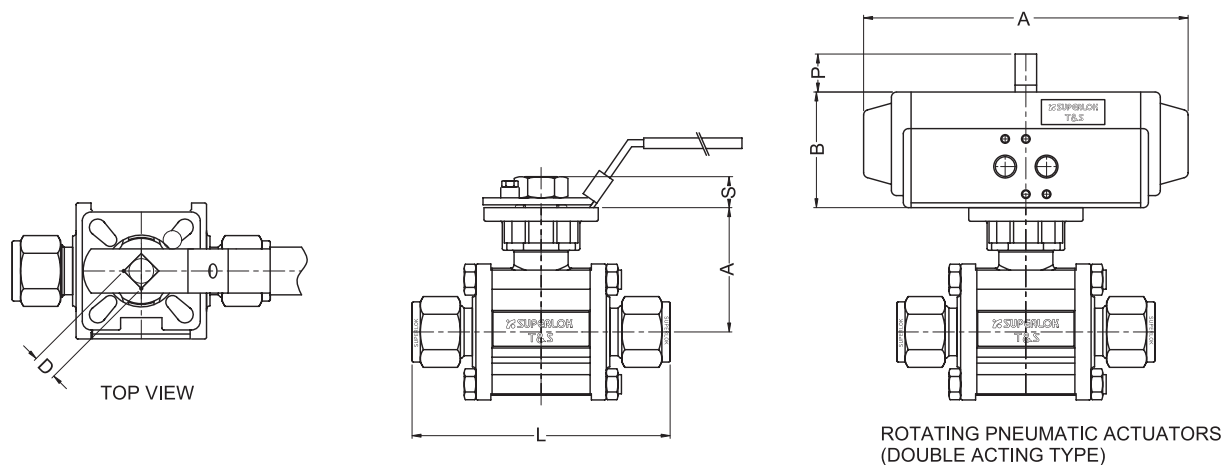

Table of Dimensions



SUPERLOK Tube End Connection

Part Number	Size	Dimension								
		A	S	D	L	A1	B	P		
SWB3101	S4	1/4 " SUPERLOK	39.0	8.5	9.0	72.6	188.0	67.0	20.0	
	S6	3/8 " SUPERLOK				74.2				
	S8	1/2 " SUPERLOK				75.6				
	F4N(R)	1/4 " FEMALE NPT (PT)				63.5				
	F6N(R)	3/8 " FEMALE NPT (PT)								
	F8N(R)	1/2 " FEMALE NPT (PT)								
	SW4P	1/4 " SOCKET WELD								
	SW6P	3/8 " SOCKET WELD								
	SW8P	1/2 " SOCKET WELD								
	BW4P	1/4 " BUTT WELD								62.5
	BW6P	3/8 " BUTT WELD								65.5
	BW8P	1/2 " BUTT WELD								89.0
SA8	1/2 " SANITARY	9.0	86.0							
SWB3102	S12	3/4 " SUPERLOK	43.0	8.5	9.0	86.0	188.0	67.0	20.0	
	F12N(R)	3/4 " FEMALE NPT (PT)				72.5				
	SW12P	3/4 " SOCKET WELD				76.2				
	BW12P	3/4 " BUTT WELD				102.0				
	SA12	3/4 " SANITARY				9.0				104.0
SWB3103	S16	1 " SUPERLOK	53.0	11.4	9.0	104.0	188.0	67.0	20.0	
	F16N(R)	1 " FEMALE NPT (PT)				81.0				
	SW16P	1 " SOCKET WELD				86.0				
	BW16P	1 " BUTT WELD				124.0				
	SA16	1 " SANITARY				11.0				11.0
SWB3104	F24N(R)	1-1/2 " FEMALE NPT (PT)	70.0	14.0	11.0	104.0	234.0	86.0	20.0	
	SW24P	1-1/2 " SOCKET WELD				119.0				
	BW24P	1-1/2 " BUTT WELD				141.0				
	SA24	1-1/2 " SANITARY				14.0				14.0
SWB3105	F32N(R)	2 " FEMALE NPT (PT)	78.0	13.7	14.0	121.5	234.0	86.0	20.0	
	SW32P	2 " SOCKET WELD				131.4				
	BW32P	2 " BUTT WELD				162.0				
	SA32	2 " SANITARY				14.0				14.0

• All dimensions in millimeters unless specified as "inch". Dimension are for reference only, subject to change.

Oval handle

Oval as an option. If require oval handle as option, add OH to the end of ordering number.

ex) SWB3202-S12-OH

Actuator

We can provide pneumatic actuation package as optional item with following features. If require actuator as option, add P(number) to the end of ordering number.

ex) SWB3202-F6N-P3

Ordering Information

Example: **SWB3202 - S 12 - PE - OH - SS**

1
2
3
4
5
6

1. Valve Series

SWB3201 SWB3101
 SWB3202 SWB3102
 SWB3203 SWB3103
 SWB3204 SWB3104
 SWB3205 SWB3105

2. Port Type

S : SUPERLOK Tube Fitting
 M : Male Thread
 F : Female Thread
 SW : Socket Weld
 BW : Butt Weld
 SA : SANITARY

3. Port Size

Tube O.D Designation

Tube O.D (inch)	1/4	3/8	1/2	3/4	1	1-1/4	1-1/2	2
Designation	4	6	8	12	16	20	24	32
Tube O.D (mm)	6	8	10	12	20	25	32	38
Designation	6M	8M	10M	12M	20M	25M	32M	38M

Pipe Thread Designation

Size (inch)	1/8	1/4	3/8	1/2	3/4	1	1-1/4	1-1/2	2
Screwed BSPT	2R	4R	6R	8R	12R	16R	20R	24R	32R
Screwed NPT	2N	4N	6N	8N	12N	16N	20N	24N	32N

Socket Weld & Butt Weld Designation

Size (inch)	1/4	3/8	1/2	3/4	1	1-1/4	1-1/2	2
Tube	4T	6T	8T	12T	16T	20T	24T	32T
Pipe	4P	6P	8P	12P	16P	20P	24P	32P

4. Seat Material

BLANK : GLASS15% PTFE (T1)
 PE : PEEK
 PT : PTFE
 T2 : GLASS25% PTFE
 T3 : CARBON15% PTFE
 T4 : CARBON25% PTFE

5. Option

OH : Oval Handle
 Actuator
 - P1 : Single Acting - 90° Turn
 - P2 : Single Acting - 180° Turn
 - P3 : Double Acting - 90° Turn
 - P4 : Double Acting - 180° Turn

6. Body Material

SS : 316 Stainless Steel

Examples

ex1) SWB3103 - SA16 - SS

SWB3103 Series / [Port1]SANITARY x [Port2]SANITARY / Port Size: 1" x 1"
 Seat Material: R-PTFE / Body Material: 316 Stainless Steel

ex2) SWB3201 - S6 - T4 - SS

SWB3201 Series / [Port1]SUPERLOK x [Port2]SUPERLOK / Port Size: 3/8" x 3/8"
 Seat Material: Carbon PTFE / Body Material: 316 Stainless Steel