

2SA1082 TRANSISTOR (PNP)

FEATURES

- Low Frequency Amplifier

MARKING

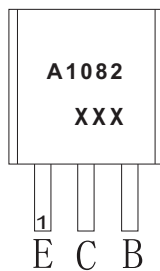

TO - 92

1. EMITTER
2. COLLECTOR
3. BASE

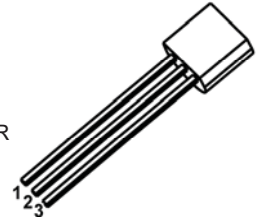

Equivalent Circuit

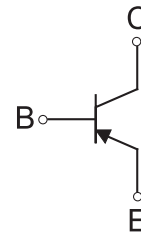

ORDERING INFORMATION

Part Number	Package	Packing Method	Pack Quantity
2SA1082	TO-92	Bulk	1000pcs/Bag

MAXIMUM RATINGS (T_a=25°C unless otherwise noted)

Symbol	Parameter	Value	Unit
V _{CB0}	Collector-Base Voltage	-120	V
V _{CEO}	Collector-Emitter Voltage	-120	V
V _{EBO}	Emitter-Base Voltage	-5	V
I _C	Collector Current	-0.1	A
P _C	Collector Power Dissipation	400	mW
R _{θJA}	Thermal Resistance From Junction To Ambient	312	°C/W
T _J , T _{stg}	Operation Junction and Storage Temperature Range	-55~+150	°C

$T_a=25\text{ }^\circ\text{C}$ unless otherwise specified

Parameter	Symbol	Test conditions	Min	Typ	Max	Unit
Collector-base breakdown voltage	$V_{(BR)CBO}$	$I_C=-0.01\text{mA}, I_E=0$	-120			V
Collector-emitter breakdown voltage	$V_{(BR)CEO}$	$I_C=-1\text{mA}, I_B=0$	-120			V
Emitter-base breakdown voltage	$V_{(BR)EBO}$	$I_E=-0.01\text{mA}, I_C=0$	-5			V
Collector cut-off current	I_{CBO}	$V_{CB}=-50\text{V}, I_E=0$			-0.1	KA
Emitter cut-off current	I_{EBO}	$V_{EB}=-2\text{V}, I_C=0$			-0.1	KA
DC current gain	h_{FE}	$V_{CE}=-12\text{V}, I_C=-2\text{mA}$	250		800	
Collector-emitter saturation voltage	$V_{CE(sat)}$	$I_C=-10\text{mA}, I_B=-1\text{mA}$			-0.2	V
Base-emitter voltage	V_{BE}	$V_{CE}=-12\text{V}, I_C=-2\text{mA}$		-0.6		V
Collector output capacitance	C_{ob}	$V_{CB}=-10\text{V}, I_E=0, f=1\text{MHz}$		3.5		pF
Transition frequency	f_T	$V_{CE}=-12\text{V}, I_C=-2\text{mA}$		90		MHz

CLASSIFICATION OF h_{FE}

RANK	D	E
RANGE	250-500	400-800

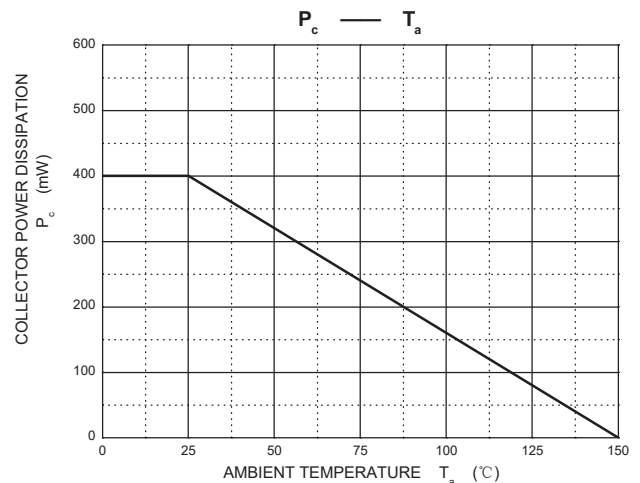
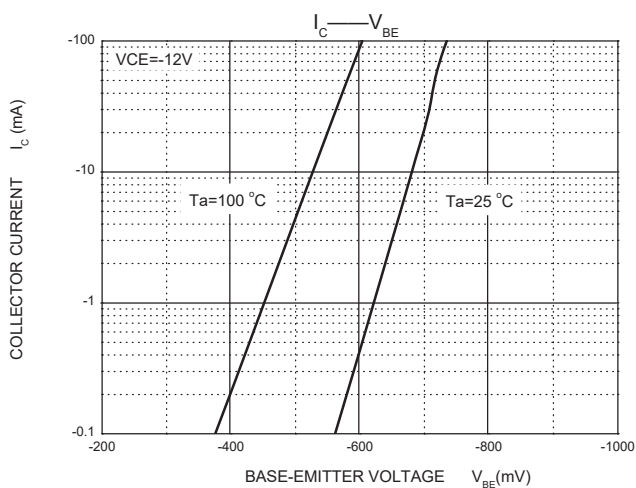
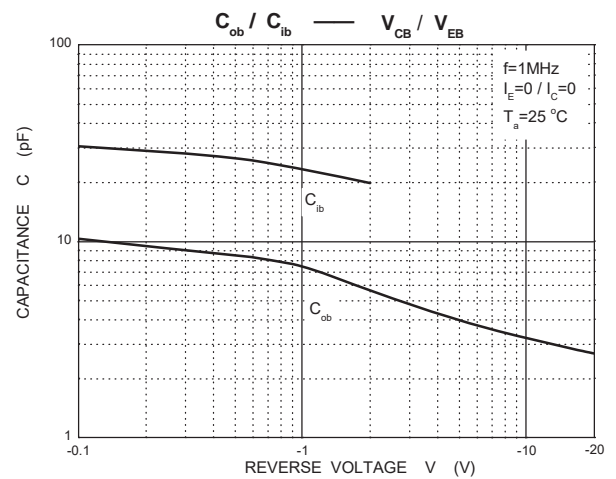
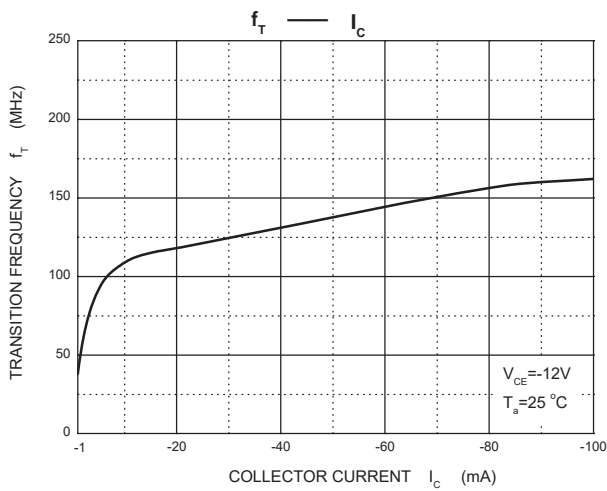
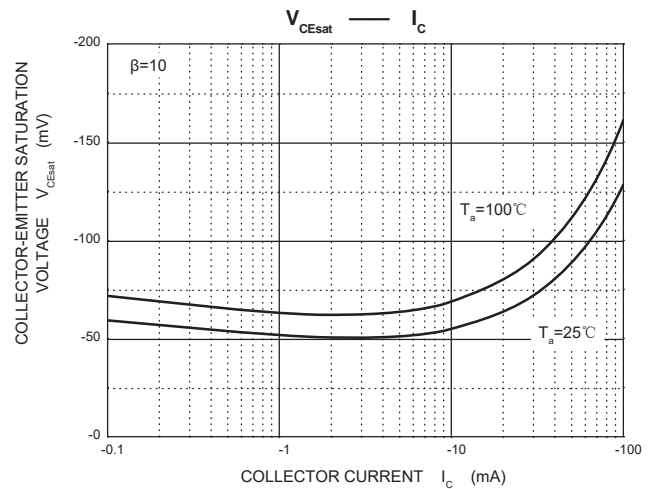
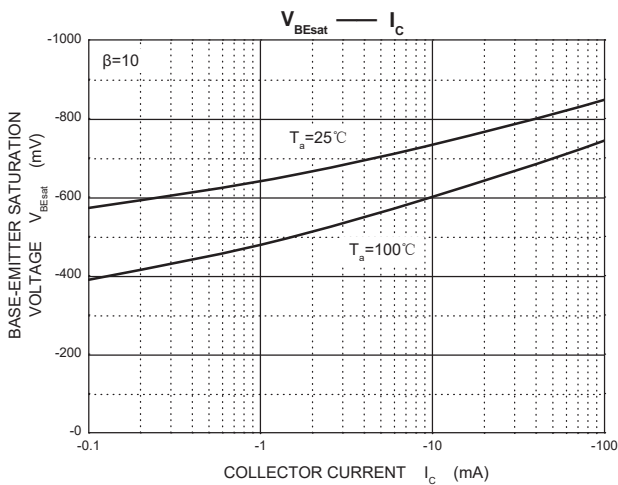
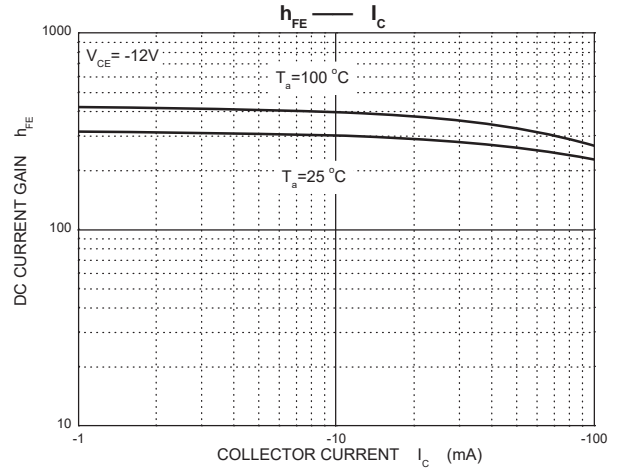
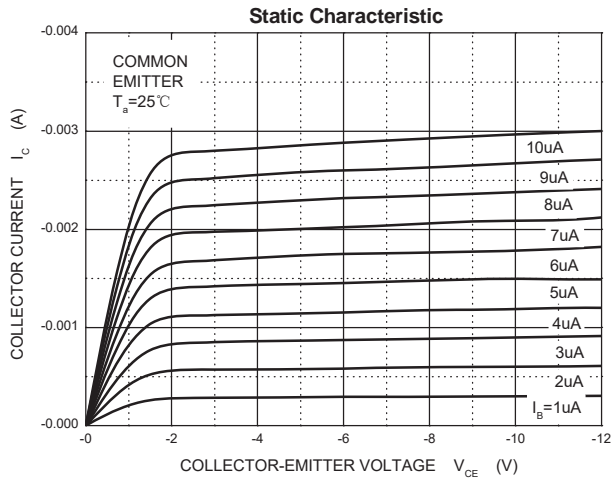

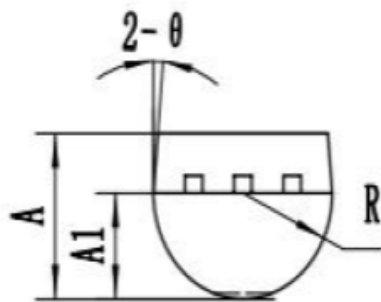
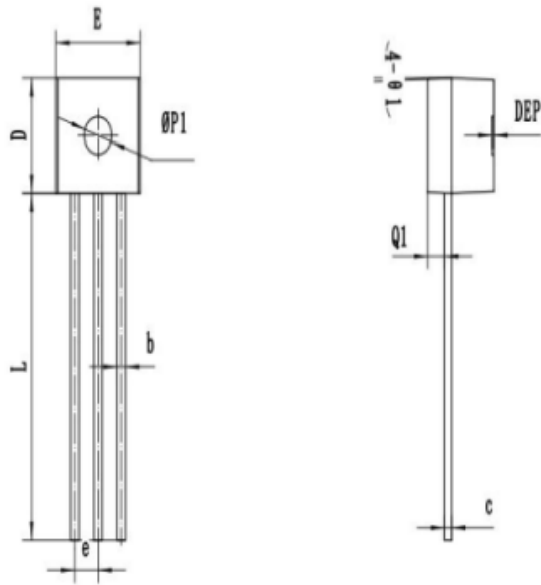

SYMBOL	MM		
	MIN	NOM	MAX
*A	3.00	3.25	3.50
A1	2.20	2.30	2.40
*b	0.40	0.45	0.50
*c	0.25	0.30	0.35
*D	4.50	4.60	4.70
*E	4.50	4.60	4.70
*e	1.22	1.27	1.32
*L	14.00	14.30	14.60
R	2.20	2.30	2.40
Q1	0.85	0.90	0.95
θ	3°	5°	7°
Ø1	1°	3°	5°
ØP1	1.40	1.50	1.60
DEP	0.05	0.10	0.20
带*为检验尺寸			