

## 2SA673 TRANSISTOR (PNP)

### FEATURES

- Low Frequency Amplifier
- Complementary Pair with 2SC1213

### TO - 92

1. EMITTER
2. COLLECTOR
3. BASE

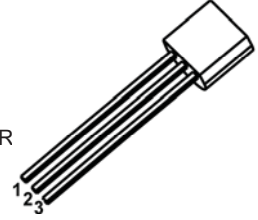

### MARKING

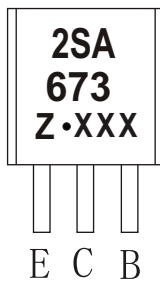

### Equivalent Circuit

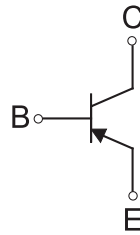

### ORDERING INFORMATION

Part Number	Package	Packing Method	Pack Quantity
2SA673	TO-92	Bulk	1000pcs/Bag

### MAXIMUM RATINGS (T<sub>a</sub>=25°C unless otherwise noted)

Symbol	Parameter	Value	Unit
V <sub>CB0</sub>	Collector-Base Voltage	-35	V
V <sub>CEO</sub>	Collector-Emitter Voltage	-35	V
V <sub>EBO</sub>	Emitter-Base Voltage	-4	V
I <sub>c</sub>	Collector Current -Continuous	-0.5	A
P <sub>D</sub>	Collector Power Dissipation	400	mW
R <sub>θJA</sub>	Thermal Resistance from Junction to Ambient	312	°C /W
T <sub>J</sub> ,T <sub>stg</sub>	Operation Junction and Storage Temperature Range	-55~+150	°C

$T_a=25\text{ }^\circ\text{C}$  unless otherwise specified

Parameter	Symbol	Test conditions	Min	Typ	Max	Unit
Collector-base breakdown voltage	$V_{(BR)CBO}$	$I_C=-0.01\text{mA}, I_E=0$	-35			V
Collector-emitter breakdown voltage	$V_{(BR)CEO}$	$I_C=-1\text{mA}, I_B=0$	-35			V
Emitter-base breakdown voltage	$V_{(BR)EBO}$	$I_E=-0.01\text{mA}, I_C=0$	-4			V
Collector cut-off current	$I_{CBO}$	$V_{CB}=-20\text{V}, I_E=0$			-0.5	$\mu\text{A}$
Emitter cut-off current	$I_{EBO}$	$V_{EB}=-3\text{V}, I_C=0$			-0.5	$\mu\text{A}$
DC current gain	$h_{FE(1)}$	$V_{CE}=-3\text{V}, I_C=-10\text{mA}$	60		320	
	$h_{FE(2)}^*$	$V_{CE}=-3\text{V}, I_C=-500\text{mA}$	10			
Collector-emitter saturation voltage	$V_{CE(sat)}^*$	$I_C=-150\text{mA}, I_B=-15\text{mA}$			-0.6	V
Base-emitter voltage	$V_{BE}$	$V_{CE}=-3\text{V}, I_C=-10\text{mA}$			-0.75	V

\*Pulse test: pulse width  $\leq 300\mu\text{s}$ , duty cycle  $\leq 2.0\%$ .

#### CLASSIFICATION OF $h_{FE(1)}$

RANK	B	C	D
RANGE	60-120	100-200	160-320

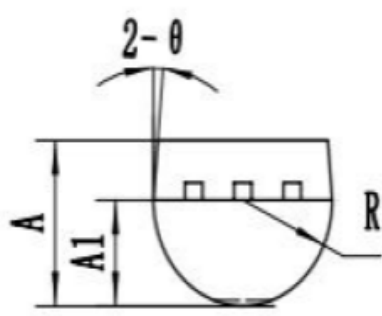
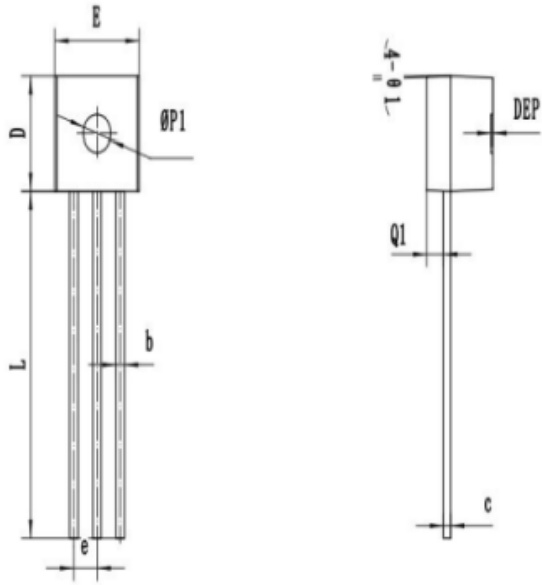

SYMBOL	MM		
	MIN	NOM	MAX
*A	3.00	3.25	3.50
A1	2.20	2.30	2.40
*b	0.40	0.45	0.50
*c	0.25	0.30	0.35
*D	4.50	4.60	4.70
*E	4.50	4.60	4.70
*e	1.22	1.27	1.32
*L	14.00	14.30	14.60
R	2.20	2.30	2.40
Q1	0.85	0.90	0.95
θ	3°	5°	7°
Ø1	1°	3°	5°
ØP1	1.40	1.50	1.60
DEP	0.05	0.10	0.20
带*为检验尺寸			