

1. Description

C9650 is a hand-tune and free debugging single radio chip with FM / AM / SW / LW /WB(Weather band) multi-band. Thanks to its monolithic integrated frequency synthesizers, radio frequency front end and MPX decoder ,this chip implements all receiver function from wireless input to audio output, eliminating the correction of the conventional PVC in the weeks of complex peripheral circuit and complex debugging correction production process.

C9650 chip integrates a high-performance low intermediate frequency digital audio DSP, so that the chip has an excellent sound quality in various receiving condition.

C9650 chip with AFC function so that make it an excellent performance and flexibility. C9650 chip can work from 2.0V to 3.6V Wide supply voltage range.

1.1. Features

- monolithic integrated FM/AM/SW/LW/WB (weather band) radio receiver
- extremely low power consumption
 - power consumption in FM mode is less than 32mA
 - power consumption in AM mode is less than 28mA
- Worldwide FM/AM/SW/LW band support
 - AM band within 520 -1710KHz
 - FW band within 87 -108MHz
 - Single FW band within 64 -108MHz
 - SW band within 3.20MHz-23.00MHz
 - LW band within153KHz-288KHz
- Support weather warning the United States (Weather band) band
 - 1050Hz is fast and accurate alarm
 - 1050Hz alarm indicator lamp
- support PVR manual search radio station
- support 32.768KHz crystal oscillator
- Integrated digital low-IF tuner
 - Transducers under the suppression of mirror
 - high performance A/D converter
- fully integrated digital frequency synthesizers
 - Fully integrated on chip RF VCO
 - fully integrated on chip loop filter
- automatic frequency control (AFC)
- support digital automatic gain control
- digital adaptive noise cancellation
 - mono output
 - stereo output(Customer choice)
- FM / AM frequency band selection for each region
- Support 25 SW mode
- Supports the use of 24C02 selection frequency
- package types: SSOP24(RoHS)

1.2. Applications

- Weather band radio
- Desktop and portable radio
- CD/DVD player
- Mini audio
- Entertainment system
- Toys or gifts

2. Functional diagram

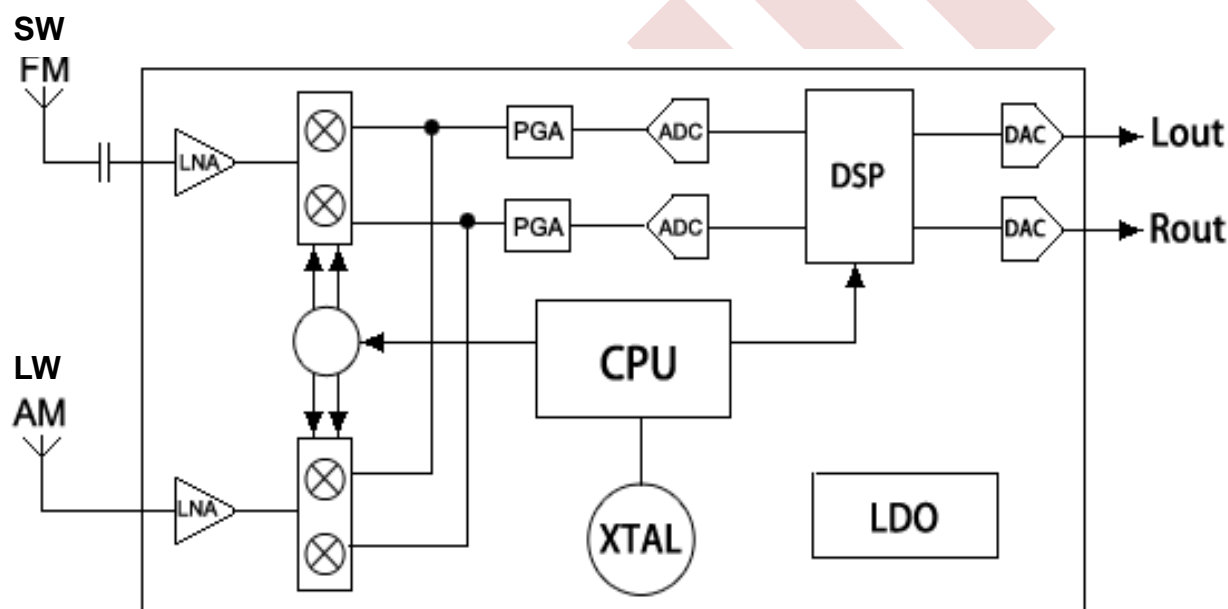

(Figure 1. C9650 Functional diagram)

3. Function Description

3.1. Overview

C9650 is a highly integrated single-chip and full-band FM / AM / SW / LW / WB receiver chip, which can realize the flexible radio receiver scheme, greatly minimizing the peripheral device chip, reducing the BOM and the cost of application, more convenient for factory production.

3.2. FM 、 WB Receiver

C9650 chip using low-IF architecture, avoiding the image rejection problems which were brought by direct frequency conversion, reducing the cost and complexity of the applications effectively. C9650 chip integrates the FM low-noise amplifier (FM_LNA) for which support the single-band (64 to 108MHz), a orthogonal image rejection mixer, a programmable gain amplifier (PGA), a high-resolution analog to digital converters, an audio DSP and a high-fidelity digital to analog converter (DAC).

C9650 chip Support weather warning the United States (Weather band) band,1050Hz is fast and accurate alarm,1050Hz alarm indicator lamp

FM_LNA amplifying the RF signal and converting it to differential signal; the orthogonal image rejection mixer change the frequency of FM-LNA differential RF signal to low-IF signal, and complete image rejection function at the same time; PGA enlarge orthogonal image reject the IF signal which were outputted by the mixer, then changing the low-IF signal which were outputted by PGA through ADC to digital signal, sending to the audio DSP for subsequent processing.

The DSP audio complete the channel selection, FM demodulation, decoding MPX stereo and audio signal output. MPX decoder can automatically complete stereo / mono switch to reduce the output noise.

3.3. AM Receiver

C9650 chip using digital low-IF architecture, supports the global AM band which the frequency ranging from 520 kHz to 1710 kHz. The AM reception of C9650 chip only requires minimal external components, and does not need manual adjustment. Digital low-IF architecture enables C9650 chip having high accuracy filter, excellent selectivity and signal to noise ratio throughout the whole AM band. Similar to the FM receiver phase, the AM receiver of C9650-chip receiver optimized the sensitivity of the receiver and the suppression for strong interference signal, making the receiver of weak signal radio easier. To provide the maximum flexibility, C9650 chip supports ferrite coil magnet of wide range. C9650 chip can also increase the effective inductance of the loop antenna through a transformer.

3.4. SW/LW Receiver

C9650 chip supports eight shortwave bands range from 3.20MHz to 23.00 MHz . Also supports arbitrary frequency range of frequency selection. The characteristics of shortwave reception of C9650 chip has few external discrete devices and does not require factory calibration. C9650 chip also supports the application of FM antenna to receive shortwave signals. LW band supports frequency range from 153KHz to 288KHz.

3.5. Frequency Synthesizer

- The vibration signal generated from frequency synthesizer is input to a quadrature mixer, RF signal down-conversion to low intermediate frequency signal of fixed frequency. The frequency of the reference clock of the frequency synthesizer is 32.768 KHz (+ 10ppm).

5. Electrical Specification

Table 1: Operation Condition

Parameter	Symbol	Operating Condition	Min	Typ	Max	Units
Power Supply	AVDD	Relative to GND	2.0	3.3	3.6	V
Ambient Temperature	Ta		-15		+85	°C

Table 2: DC Characteristics

Parameter		Symbol	Test/Operating Condition	Min	Typ	Max	Units
Current Consumption	FM/WB Model	I _{FM}			32		mA
	AM Model	I _{AM}			28		mA
	SW Model	I _{SW}			28		mA
	LW Model	I _{LW}			28		mA

(Table 3: FM Receiver Characteristics)

(VDD = 3.0 V, Ta = 0 to 45 °C)

ITEMS	Test/Operating Condition	TYP	Units
Frequency Coverage Range	Low	87	MHz
	High	108	MHz
Sensitivity For 30dB S/N	90 MHz	9	dB
	98 MHz	9	dB
	106 MHz	9	dB
S/N Ratio 60dB Input	98 MHz	54	dB
3dB Limiting Sensitivity	98 MHz	14	dB
AFC Holding Range	98 MHz	+ - 50	KHz
AM Suppression 60dB Input	98 MHz	45	dB
Distortion 60db Input	98 MHz	0.5	%
Overload THD.75 KHz Dev.	98 MHz	0.3	%
Power Output 10% T.H.D.(MOD=75KHz)	98 MHz	175	mVrms
Max.Power Output (MOD=75KHz)	98 MHz	175	mVrms
No Signal Current		13	uA
Current Drain Current at OutPut		32	mA
Modulation Hum. (100dB)		1.5	mV
Frequency Response 1mV Input with 1KHz=0dB (-6dB)	High	5	KHz
	Low	80	Hz
Level Difference Mono/Stereo	98 MHz	0	dB
Sens.For Stereo Indicator On	98 MHz	22	dB
Channel Balance	98 MHz	0.2	dB
Separation 1KHz	98 MHz	50	dB
NOTE: <ol style="list-style-type: none"> 1. Frequency is 87~108 MHz. 2. $V_{EMF} = 1$ mV. 3. FMOD = 1 kHz, MONO, and L = R unless noted otherwise. 4. $\Delta f = 22.5$ kHz. 5. $f_2 - f_1 > 2$ MHz, $f_0 = 2 \times f_1 - f_2$. 6. BAF = 300 Hz to 15 kHz, A-weighted. 7. At LOUT and ROUT pins. 8. $f = 75$ kHz. 			

(Table 4: AM Receiver Characteristics)

(VDD = 3.0 V, Ta = 0 to 45 °C)

ITEMS	Test/Operating Condition	TYP	Units
Frequency Coverage Range	Low	520	KHz
	High	1710	KHz
Sensitivity For 20dB S/N	600 KHz	83	dB/m
	1000 KHz	83	dB/m
	1400 KHz	83	dB/m
S/N Ratio (5mV/m)	1000 KHz	40	dB/m
A.G.C -10dB (100mV/m)	1000 KHz	50	dB/m
Selectivity ±9KHz	1000 KHz	18	dB/m
Band width (-6dB)	1000 KHz	12	KHz
Power Output 10% T.H.D. (Mod=80%)	1000 KHz	170	mVrms
Max. Power Output (Mod=80%)	1000 KHz	170	mVrms
Distortion 30% MOD.74dB INPUT	1000 KHz	0.5	%
Frequency Response -6dB 5mV/m Input 1KHz=0dB	Low	2.8	KHz
	High	80	Hz
Min. Volume Output		0.2	mV
Modulation Hum. (100dB)		4	mV
No Signal Current		10	uA
Current Drain Current at MAX. Output		28	mA
NOTE: 1. Volume = maximum,for all tests. Tested at RF = 520 kHz. 2. FMOD = 1 kHz, 30% modulation, 2 kHz channel filter. 3. BAF = 300 Hz to 15 kHz, A-weighted. 4. VIN = 5mVrms. 5. Stray capacitance on antenna and board must be < 10 pF to achieve full tuning range at higher inductance levels.			

(Table 5.SW Receiver Characteristics)

(VDD = 3.0 V, Ta = 0 to 45 °C)

ITEMS	Test/Operating Condition	TYP	Units
Frequency Coverage Range	Low	9.0	MHz
	High	22	MHz
Sensitivity For 20dB S/N	9.5 MHz	13	dB
	15MHz	13	dB
	20 MHz	13	dB
S/N Ratio 74dB Input	15 MHz	>35	dB
A.G.C -10dB (100mV/m)	15 MHz	40	dB
Selectivity ± 9KHz	15 MHz	± 10	dB
Band width (-6dB)	15 MHz	3- 6	KHz
Power Output 10% T.H.D. (Mod=80%)	15 MHz	50 ~ 100	mVrms
Max. Power Output (Mod=80%)	15 MHz	50 ~ 100	mVrms
Distortion 30% MOD.74dB INPUT	15MHz	< 1	%
Modulation Hum. (100dB)		< 5	mv
Max Volume output		30	mv
Min. Volume Output		0.5	mv
Frequency Response -6dB 5mV/m Input 1KHz=0dB	High	2.8	KHz
	Low	80	Hz
No Signal Current		10	uA
Current Drain Current at MAX. Output		28	uA
Spurious Frequency Rejection Ratio		9 ~ 18	dB
NOTE:			

(Table 6.LW Receiver Characteristics)

(VDD = 3.0 V, Ta = 0 to 45 °C)

ITEMS	Test/Operating Condition	TYP	Units
Frequency Coverage Range	Low	153	KHz
	High	288	KHz
Sensitivity For 20dB S/N	162 KHz	88	dB/u
	216 KHz	88	dB/u
	279 KHz	88	dB/u
S/N Ratio (74dB/m)	216 KHz	40	dB
A.G.C -10dB (100mV/m)	216 KHz	40	dB
Selectivity ±9KHz	216 KHz	±10	dB
Band width (-6dB)	216 KHz	3 - 6	KHz
Power Output 10% T.H.D. (Mod=80%)	216 KHz	50 ~ 100	mVrms
Max. Power Output (Mod=80%)	216 KHz	50 ~ 100	mVrms
Distortion 30% MOD.74dB INPUT	216 KHz	<1	%
Frequency Response -6dB 5mV/m Input 1KHz=0dB	Low	2.8	KHz
	High	80	Hz
Min. Volume Output		0.5 ~ 2.0	mV
Current Drain Current at MAX. Output		28	mA
NOTE:			

6. Chip pin description

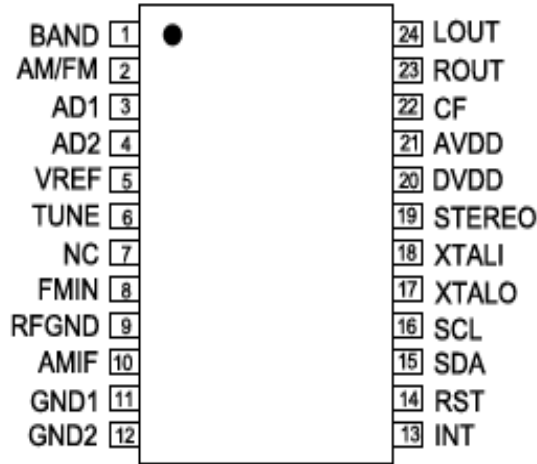

(Table 7. C9650 Chip pin description)

Pin	Pin Name	Description
1	BAND	State detection
2	AM/FM	AM / FM band switch
3	AD1	Country or Region Selection
4	AD2	Band Selection
5	VREF	Voltage Detection
6	TUNE	Frequency Tune
7	NC	NC
8	FMIN	FM RF input
9	RFGND	RF GND
10	AMIN	AM RF input
11,12	GND1、2	GND
13	INT	state detection/NC
14	RST	Reset
15	NC	NC/state detection
16	NC	NC/state detection
17	XTALO	crystal oscillator output
18	XTALI	crystal oscillator input
19	STEREO	stereo lamp
20	DVDD	digital power
21	AVDD	Analog power
22	CF	bypass capacitor filter
23	ROUT	Right output
24	LOUT(A-OUT)	Left output (MONO output)

6. C9650 chip pin settings

6.1 BAND and AM/FM pin settings

(Table 8. band selection)

BAND	AM/FM	Band selection
1	1	AM
1	0	FM

6.2 AD1 pin settings

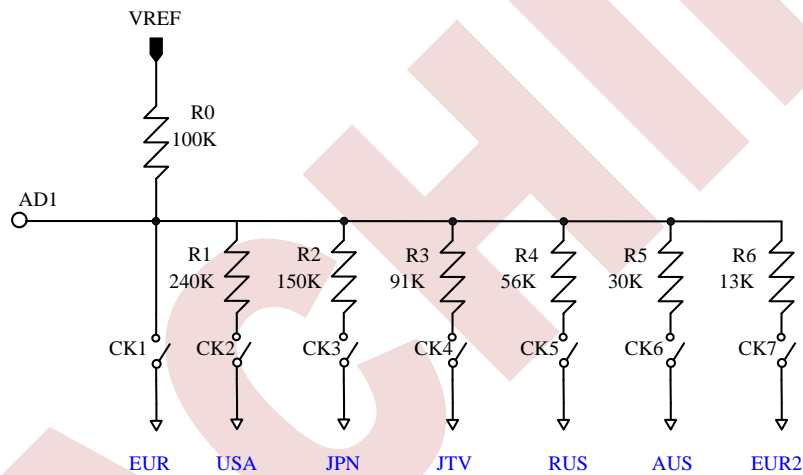

(Table 9. Countries and regions frequency range selection)

Countries or regions	switch	resistance value
EUR	CK1	0R
USA	CK2	240K
JPN	CK3	150K
JTV	CK4	91K
RUS	CK5	56K
AUS	CK6	30K
EUR2	CK7	13K

Note: The above are reference parameters, all accurate parameters should be referred to actual circuit.

(Table 10. Regional frequency range selection table)

Radio station area	Countries or regions	Hand tuning frequency width limit
EUR	Europe / Korea / Taiwan	AM Lower : 522 KHz ; AM Upper : 1620 KHz
		FM Lower : 87.0MHz ; FM Upper : 108.0 MHz
USA	U.S.A. , Canada & Latin America	AM Lower : 520 KHz ; AM Upper : 1710 KHz
		FM Lower : 87.0 MHz ; FM Upper : 108.0 MHz
JPN	Japan (without TV-Band)	AM Lower : 522 KHz ; AM Upper : 1710 KHz
		FM Lower : 76.0 MHz ; FM Upper : 95.0 MHz
JTV	Japan (with TV-Band TV1, TV2 & TV3)	AM Lower : 522 KHz ; AM Upper : 1710KHz
		FM Lower : 76.0 MHz ; FM Upper : 108.0 MHz
RUS	Russia	AM Lower : 522 KHz ; AM Upper : 1620 KHz
		FM Lower : 64.0 MHz ; FM Upper : 108.0 MHz
AUS	Australia, New Zealand & S. Africa	AM Lower : 531 KHz ; AM Upper : 1602KHz
		FM Lower : 87.5 MHz ; FM Upper : 108.0 MHz
EUR2	UNUSED(Global)	AM Lower : 522 KHz ; AM Upper : 1620KHz
		FM Lower : 87.5 MHz ; FM Upper : 108.0 MHz

SW Default narrow frequency range: (MHz)

SW1	SW2	SW3	SW4	SW5	SW6	SW7	SW8	SW9
3.20 ~ 5.50	5.60 ~ 6.50	6.60 ~ 8.00	8.50~10.00	11.00~12.50	13.00~14.50	14.60~15.90	17.00~19.00	21.00~23.00

SW Default wide frequency range: (MHz)

SW1	SW2	SW3	SW4	SW5	SW6	SW7	SW8
2.30~10.00	3.20~8.00	3.20~7.00	5.60~22.00	5.60~12.00	3.20~19.00	8.00~16.00	7.00~19.00
SW9	SW10	SW11	SW12	SW13	SW14	SW15	SW16
7.00~23.00	10.00~16.00	8.50~22.00	9.00~18.00	10.00~22.00	12.00~22.00	16.00~22.00	2.30~22.00

Note: the customer can choose the frequency range of the end of the 24C02;

7. Typical application circuit of AM/FM/WB

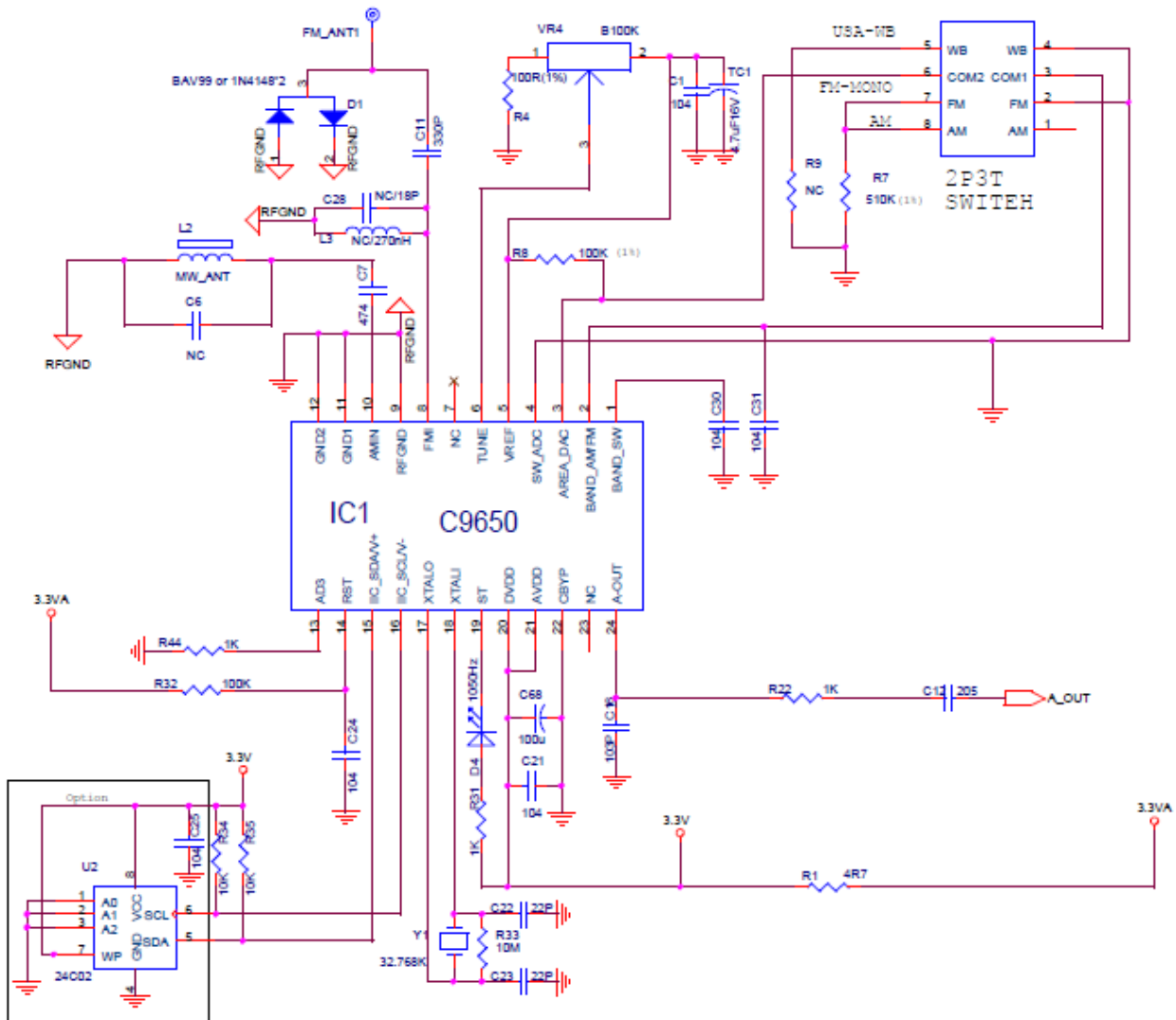

(Table11. Typical application schematic diagram)

Note: The above demonstration circuit is for the C9650 chip reference design circuit, Our company reserves the right to modify the circuit. When entering the normal product design, please obtain the latest information from our engineering staff.

8. Package

Package dimensions: SSOP 24

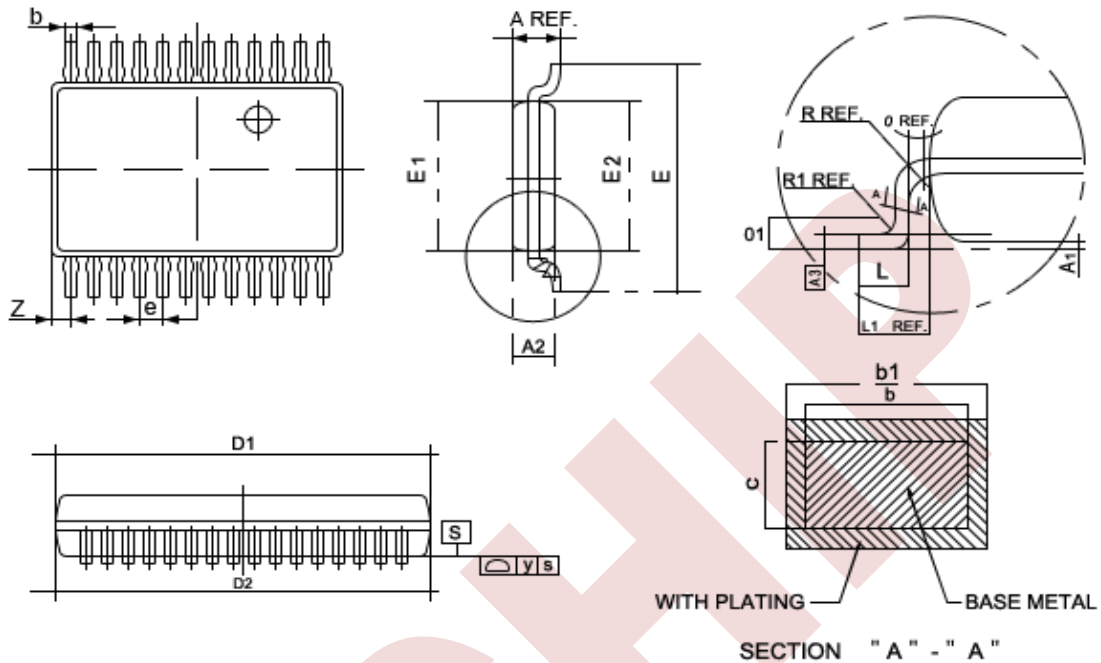

Symbol	Min	Nom	Max
A	1.500	1.600	1.700
A1	0.100	0.150	0.200
A2	1.400	1.450	1.500
A3	-----	0.203	-----
b	-----	0.254	-----
b1	0.260	0.320	0.380
c	-----	0.203	-----
D1	8.600	8.650	8.700
D2	8.610	8.660	8.710
E	5.800	6.000	6.100
E1	3.800	3.900	4.000
E2	3.850	3.950	4.050
e	-----	0.635	-----
L	0.560	0.660	0.760
L1	0.950	1.050	1.150
R	-----	0.120	-----
R1	-----	0.200	-----
θ	0	-----	-----
θ 1	0	-----	8°
y	-----	-----	0.1
Z	-----	0.838	-----

Note:

1. All dimension are in mm;
2. Dim D1/D2 & E1/E2 does not include plastic flash; flash: Plastic residual around body edge after dejunk/singulation.
3. Dim b does not include dambar protrusion/intrusion.
4. Plating thickness 0.005-0.015 mm.

(Table 12.SSOP-24 package dimension)