

CETONI

CETONI nemesys XL Hardware Manual

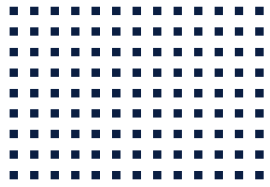

ORIGINAL MANUAL 2.03- MARCH 2020



CETONI GmbH
Wiesenring 6
07554 Korbussen
Germany

T +49 (0) 36602 338-0
F +49 (0) 36602 338-11
E info@cetoni.de

www.cetoni.de

The information and data contained in this document are subject to change without notice. CETONI GmbH is constantly striving to develop all its products. This means that there may be changes in form, equipment and technology. Claims can therefore not be made on the basis of information, illustration or descriptions in these instructions. The description for the product specification in this manual does not constitute an integral part of the contract.

If you control the products with a software from CETONI GmbH, you agree to the applicable license agreement, which can be read in the corresponding software manual. This and all other current product manuals can be found at <https://www.cetoni.de/en/downloads/manuals>.

CETONI GmbH grants its customers the right to reproduce this manual for the purpose of providing technical information to potential users of CETONI products. Extracts of these documents may only be reproduced or transmitted with a precise reference to the authorship of CETONI GmbH, irrespective of the manner in which they are reproduced or transmitted, either electronically or mechanically. Any duplication or use of excerpts for other purposes requires the written permission of CETONI GmbH.

We are always open to comments, corrections and requests. Please send them to info@cetoni.de.

The general terms and conditions of CETONI GmbH shall apply. Alternative agreements must be in written form.

Copyright © CETONI GmbH – Automation and Microsystems. All rights reserved.

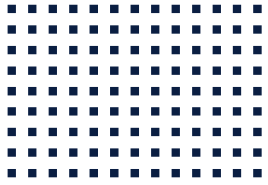

1 Overviews & Directories

1.1 Content

1	Overviews & Directories	5
1.1	Content	5
1.2	Revision History	7
2	Introduction	8
2.1	Foreword	8
2.2	Symbols and Keywords Used	8
2.3	Norms and Directives	9
2.4	Application Purpose	9
2.4.1	General Description of the Device	9
2.4.2	Intended Use	9
2.4.3	Reasonably Foreseeable Faulty Application	9
2.4.4	Security Measures	9
2.4.5	Measures for Safe Operation	11
2.4.6	Safety Features of the Device	11
2.4.7	Device Condition	12
2.5	Warranty and Liability	12
3	Scope of Delivery	13
4	Technical Data	15
4.1	Operating Environment	15
4.2	Mechanical Data	15
4.3	Electrical Data	15
4.4	Interfaces	15
4.5	Wetted Parts	16
4.6	Dimensions	16

5 Initial Start-Up	17
5.1 Software Installation	17
5.2 Set Up the Device	17
5.3 Connect the Device	17
5.3.1 Connection and Operation as a Single Device	18
5.3.2 Use with an Existing neMESYS or Qmix System	19
5.3.3 Connecting Additional Modules to the neMESYS Ultra High Pressure Module	19
5.3.4 Connection via RS232	20
6 Operating the Hardware	22
6.1 Syringes	22
6.1.1 Maintenance of the Syringes	22
6.1.2 Syringe Configuration	22
6.1.3 Installation on the Device	22
6.2 Fluidic Connection	25
6.2.1 High Pressure Connection (for 10 ml Syringe)	26
6.2.2 Reducer Union	28
6.3 Signal interface	30
6.4 Overload Clutch	31
6.4.1 Overload Procedure	32
6.5 Valve Interface	33
7 Transport and Storage	34
8 Maintenance and Care	35
9 Disposal	36

1.2 Revision History

REV	DATE	CHANGES	VALID FOR
1.00	03.08.2012	Creation of the NEMESYS XL module hardware manual	NEM-B206-01 A
1.01	14.01.2012	Changes considering the new 12-pole sensor interface	NEM-B206-01 B
1.02	21.02.2013	Added colors to the 12-pole sensor interface table	
1.03	06.02.2014	Changes considering the 12-pole sensor interface	
1.04	06.05.2015	Added notes regarding the Pressure Equipment Directive 2014/68/EU, corrected address	
2.00	21.01.2016	New layout, changes in connection technology and 10 ml syringe	NEM-B206-01 C
2.01	10.03.2016	Revision Manual Design	
2.02	08.04.2016	Removed Digital Input 3 from I/O interface table because it is not available	
2.03	06.03.2020	Adaptation of the scope of delivery	NEM-B206-01 D



IMPORTANT. In its current revision, this manual applies only to the product types listed in the last line. Should you require a manual from a previous revision, please do not hesitate to contact us. Please let us know your device type and email address and we will send you the appropriate manual as a pdf file.

The type of your product can be found on the label behind "Type:", according to the marked number in the following example:



2 Introduction

2.1 Foreword

Thank you for purchasing a product from CETONI. With this user manual we would like to support you as well as possible when handling the device. If you have any questions or suggestions, please do not hesitate to contact us.

2.2 Symbols and Keywords Used

The following symbols are used in this manual and should assist you in navigating through this document:



TIPP. Describes practical tips and useful information to facilitate the handling of the device.



IMPORTANT. Describes important information and other especially useful notes, in which no dangerous or damaging situations can arise.



CAUTION. Identifies a potentially harmful situation. Failure to avert this situation may result in damage to the product or anything in its proximity.



ATTENTION. Indicates a potentially dangerous situation. Failure to avert this situation may result in light or minor injuries or damages.

2.3 Norms and Directives



cetoni GmbH declares under its sole responsibility, that the individual neMESYS devices and the entire neMESYS syringe pump system comply with the health and safety requirements of the relevant European directives.

2.4 Application Purpose

2.4.1 General Description of the Device

The neMESYS Ultra High Pressure module is a syringe pump. It allows the emptying and filling of syringes by a relative linear movement between a syringe holder and a syringe piston holder.

2.4.2 Intended Use

The neMESYS Ultra High Pressure module is for the precise and pulsation-free dosage of fluid streams with an operating pressure of up to 890 bar and flow rates of nanoliters to milliliters per second. Its default operating environment is a laboratory-like room.

2.4.3 Reasonably Foreseeable Faulty Application

A use for applications distinct from the intended purpose can lead to dangerous situations and is to be omitted.

2.4.4 Security Measures

Safety for the operator as well as trouble-free operation of the device are ensured only when using original equipment parts and original accessories. Warranty claims will not be accepted for damage due to the use of alien accessories or expendables.

The device has been developed and designed to avoid harmful situations during intended use. However, the following safety measures have to be observed to exclude potentially remaining risks:

- CETONI GmbH points out the operator responsibility during use. Relevant laws and regulations at the location of use must be observed. In the interest of safety, operators and users are responsible to adhere to all relevant regulations.
- The device must neither be used as a medical product nor in medical applications.

- The device is designed and approved to work in fluidic systems, which fall within the scope of Article 4 Paragraph 3 of the Pressure Equipment Directive 2014/68/EU.

This means that the system may not exceed a maximum volume of 1 liter. With the use of fluids from Group 1 according to Article 13 of the Pressure Equipment Directive 2014/68/EU, the maximum allowable system pressure is 200 bar. For fluids from Group 2 it is 1000 bar. If different, product-specific values for the maximum pressure are given in the section "Technical Data", these values must be complied with. Regarding the maximum operating temperature, the specification from the section "Technical Data" must be observed.

CETONI GmbH is not liable for consequences that may arise if the user expands the system by peripheral devices, such that one of the values or both values are exceeded.

It is the user's responsibility to become familiar with the mentioned Pressure Equipment Directive and to comply with the prevailing requirements.

- The operator has to ensure functional safety and proper condition of the device before use.
- The operator must be familiar with how to operate the device and the software.
- The device, accessories, and cables must be checked for damages before use. Damaged cables and interfaces must be replaced immediately.
- Cables are to be laid out such as to prevent the danger of tripping.
- The device must only be operated with the safety cover firmly attached. Any safety installations must not be tampered with nor rendered in-operational.
- Touching any of the devices moving parts during operation must be avoided due to the danger of contusions.
- It is forbidden to use the device in an explosive atmosphere or with potentially explosive materials.
- Safety goggles must be worn when operating or handling the device, in particular with corrosive, hot, or otherwise dangerous substances.
- Potential leakages at the device or connected parts and accessories may cause medium to exit under high pressures. This may cause potentially harmful situations. Tight fittings of all interconnected parts and the use of safety goggles must be ensured at all times.
- Please note that continuous use of the device may cause wear of the syringes. This may increase the likelihood of leakages. Leaking syringes must be replaced immediately.
- Assembly tasks, such as replacing of the syringe, may only be carried out when the device is not operating and completely de-pressurized. The device must not be shut down or stored with pressurized syringes. Before switching off the software that operates the device, the syringe must be de-pressurized.

- Operate the device on safety benches equipped with an emergency-stop button.
- The user has to ensure that the application setup includes measures and devices, such as safety valves, that relieve the system pressure in case of errors or malfunctions.
- Only stainless steel syringes specified for the device are to be used to avoid dangers due to bursting syringes.
- Transport, storage, and operation of the device at a temperature below 0°C/32°F with water within the fluidic system may cause damage to the device.

2.4.5 Measures for Safe Operation

- Electromagnetic emissions

The device is intended for use in any type of facility, connected directly to the public power supply network that supplies buildings used for domestic purposes.

- Electrostatic discharge

Floors should be made of wood, concrete, or ceramic tiles. If the flooring is made of a synthetic material, the relative humidity must be at least 30%.

- Electric disturbances

The quality of the supply voltage should be to the standard of a typical business or hospital environment.

- Magnetic disturbances

Do not place power connector cables, even of other appliances, in close proximity of the devices and their cables. Mobile communication devices may not be used in closer proximity of the devices or their cables than the recommended safety distance!

2.4.6 Safety Features of the Device

In case of an emergency, the device may be switched off at any time by pulling the power supply connector. This will cause no damage to the device itself.

Additionally, the device features a safety cover that shields all moving parts and reduces the risk of injury. Removing the cover will stop and switch off the device.

Using the pressure sensor interface, the device may be programmed to automatically stop if a preset maximum pressure is exceeded.

To avoid damage, the device is equipped with an overload clutch that will disconnect the driving unit and switch off the device in case of failure.

2.4.7 Device Condition

Despite a faultless manufacture of the unit, damage may occur at any time whilst the unit is in operation. With this in mind, the user must always carry out a visual check of the device and any attached or co-operated components prior to use. Particular attention must be paid to crushed power cables and deformed plugs as well as damaged feed lines (tubing, capillaries, etc.). If any damage to the device is noticed, the device is not to be used and CETONI GmbH should be informed. CETONI will ensure that operational conditions are reestablished within a reasonable time. Do not attempt to repair the unit yourself.

2.5 Warranty and Liability

This device left our company in perfect condition. Only the manufacturer is permitted to open the device. All guarantee and liability entitlements, in particular damage entitlements due to personal injuries, are void if the unit is opened by personnel not authorized by CETONI.

The duration of the warranty is 1 year from the date of delivery. It is not extended or renewed due to work carried out under warranty.

CETONI GmbH considers itself responsible for the unit with regard to safety, reliability, and function only if assembly, new settings, changes, extensions, and repairs are carried out by CETONI GmbH or an authorized center or agent, and if the unit has been used in accordance with this instruction manual.

The device conforms to the basic safety regulation standards. Industrial property rights are reserved on the circuits, methods, names, software programs, and devices.

3 Scope of Delivery

The following items should be included

NEMESYS ULTRA HIGH PRESSURE MODULE

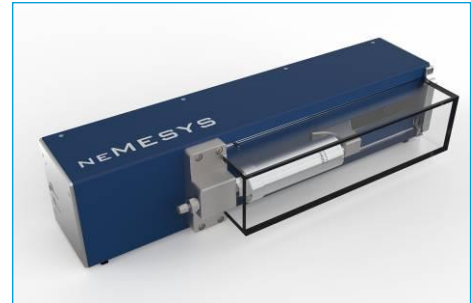

POWER SUPPLY

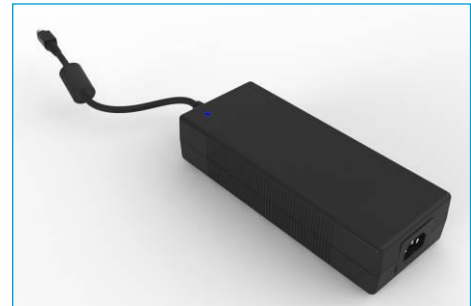

MAINS CABLE

(US or EU model as applicable)

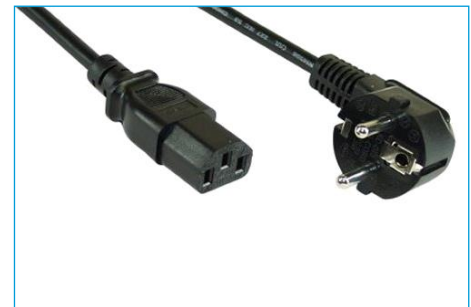

USB-TO-CAN ADAPTER



CAN CONNECTOR CABLE OR INTERCONNECT CABLE



TERMINATOR PLUG



SYRINGE(S) AS PER ORDER



MANUAL & SOFTWARE CD

- Device drivers for the USB interface
- QmixElements Software
- Qmix device configuration
- Qmix SDK (optional)



4 Technical Data

4.1 Operating Environment

OPERATING TEMPERATURE	0°C ~ 45°C
STORAGE TEMPERATURE	-20°C ~ 75°C
OPERATING HUMIDITY	20% – 90%, not condensing
STORAGE HUMIDITY	20% – 90%, not condensing
SOUND POWER LEVEL	≤70 dB(A)

4.2 Mechanical Data

WEIGHT	21 kg
DIMENSIONS (L x W x H)	600 x 194 x 146 mm

4.3 Electrical Data

SUPPLY VOLTAGE (POWER SUPPLY)	90 ~ 264VAC
FREQUENCY	47 ~ 63 Hz

4.4 Interfaces

CAN	max. 1 Mbit / s
RS-232	max. 115200 bit/s

4.5 Wetted Parts

SYRINGES AND SYRINGE HOLDER

Stainless Steel

SEALING GASKET

EPDM / NBR / FKM



CAUTION. Check the chemical resistance of the wetted parts against the used chemicals before using the device.

4.6 Dimensions

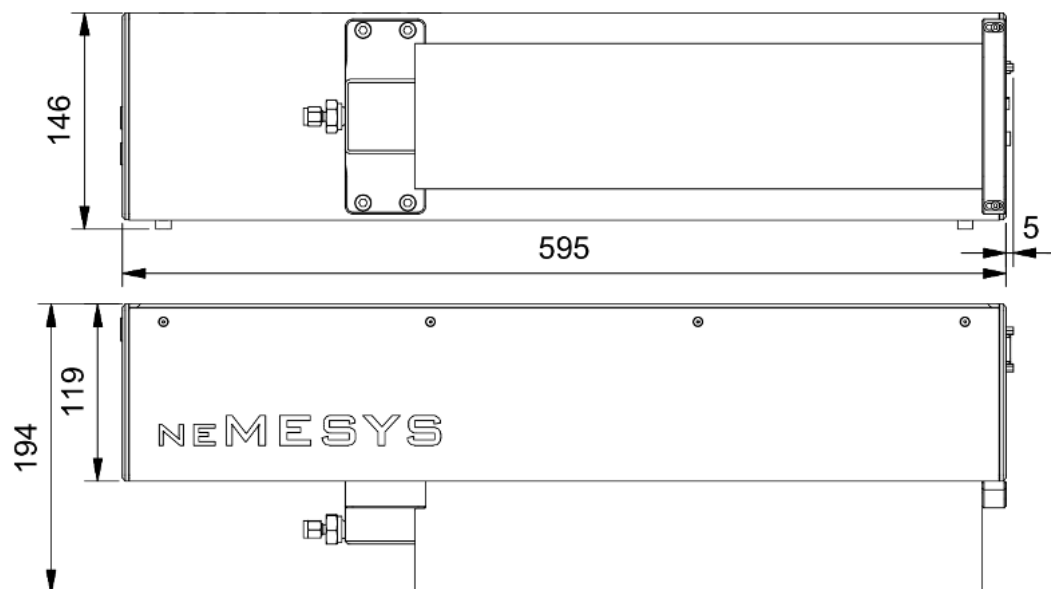

5 Initial Start-Up

To ensure a trouble-free initial operation of your neMESYS Ultra High Pressure module, work through the sections below.



IMPORTANT. Please read this manual and the accompanying software manual carefully and completely before setting up and operating your neMESYS Ultra High Pressure module.

5.1 Software Installation

Supplied software and drivers must be installed prior to connecting this or any other CETONI device to a computer. Please refer to the accompanying software manual, which may be found on the supplied CD, for a detailed description.



IMPORTANT. Please follow the instructions and install software and device drivers before connecting the device to your PC via USB.

5.2 Set Up the Device

Place the neMESYS Ultra High Pressure module on an even and horizontal surface, such as a table, base cabinet or instrument trolley. Make sure that the surface has an adequate load capacity and keep a sufficient distance from the edge, to prevent the device from falling down.

5.3 Connect the Device

After having installed software and drivers you are ready to take the device into operation. The steps required for (re-)connecting the neMESYS Ultra High Pressure module, either stand-alone or in combination with additional devices, are detailed in the software manual that should be consulted prior to initial operation.

There are various alternatives for how the neMESYS Ultra High Pressure module may be connected and used – these are explained in more detail below.

5.3.1 Connection and Operation as a Single Device

Connect the USB plug of the USB-to-CAN adaptor with an available USB port (USB Type A) of your PC. Next, use the provided D-Sub-to-IXXAT cable to connect the 9 pin D-Sub plug of the USB-to-CAN adaptor with the neMESYS Ultra High Pressure module's CAN socket (male) right above the power socket.

Attach the terminator plug to the upper CAN socket (female) of the XL module.



IMPORTANT. Always plug the terminator plug into the socket of the last module in your system. Otherwise there may be disruptions in data communication.

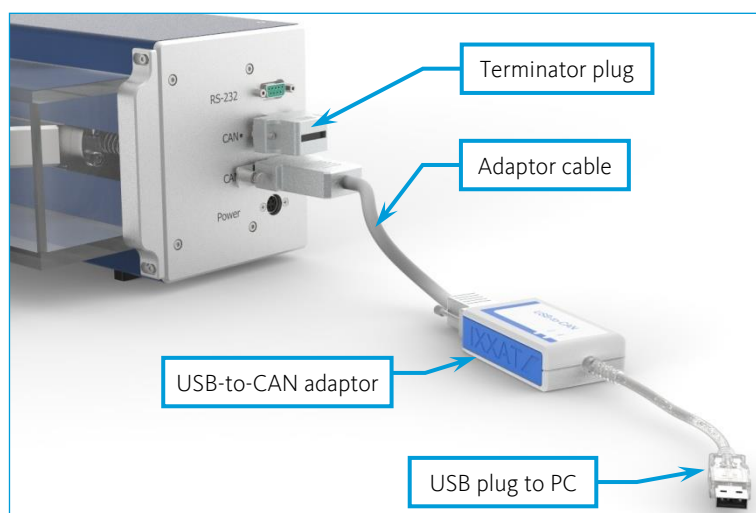

Connect the plug of the provided power supply to the respective port of the neMESYS Ultra High Pressure module labeled *Power*. The flattened side of the plug with the two small arrows has to point upwards.

The plug locks into place. To unplug, you must pull the back the black sleeve of the plug with the two small arrows – do not pull the cable directly.

Use the supplied equipment connection cable to connect the power supply with the power socket (mains). The device may be used with voltages from 90 to 264 V (AC, alternating current) at 47 to 63 Hz.

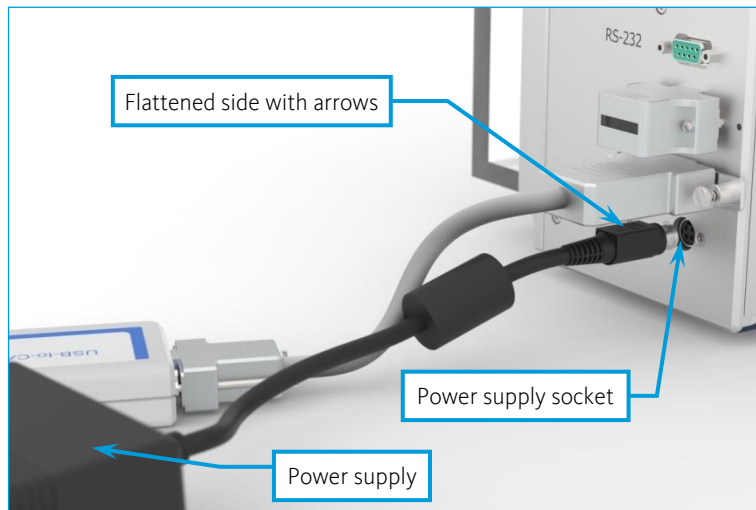

5.3.2 Use with an Existing neMESYS or Qmix System

The neMESYS Ultra High Pressure module can be connected to an existing neMESYS or Qmix system. In this case, you do not need the USB-to-CAN adapter, because this is already included in the base module of the system. Then, use a CAN Interconnect cable to connect the lower CAN socket (male) of your new XL module to the CAN socket of the last module of the existing system. Interconnect cables are available from CETONI GmbH.

Since the base modules only provide 24 VDC, but the neMESYS Ultra High Pressure module requires a power supply of 48 VDC, it cannot be supplied by a base module, but needs its own power supply. The connection of terminator plug and power supply is carried out as described in section Fehler! Verweisquelle konnte nicht gefunden werden..



IMPORTANT. Please read and follow the appropriate section in the accompanying software manual before connecting additional devices.

5.3.3 Connecting Additional Modules to the neMESYS Ultra High Pressure Module

The neMESYS Ultra High Pressure module provides 24 VDC at 2 A via the upper connector labeled CAN. This makes it possible to connect for example up to five dosing or two medium pressure modules via an interconnect cable. The last module in the sequence then has to have the terminator plug attached to its CAN (out) port.



IMPORTANT. Please read and follow the appropriate section in the accompanying software manual before connecting additional devices.

5.3.4 Connection via RS232

The neMESYS Ultra High Pressure module provides a standard 9-pin D-Sub socket as RS232 interface.



Connection via RS232

On the neMESYS Ultra High Pressure module PIN 2 is the output. It must be connected to the input of the RS232 interface on the PC (usually also PIN2).

The input is PIN 3 on the neMESYS Ultra High Pressure module and must be connected to the output of the RS232 interface on the PC (usually also PIN3).

The signal ground is PIN 5 on the neMESYS Ultra High Pressure module. It is usually also PIN 5 on the PC's RS232 interface.

The neMESYS Ultra High Pressure module may be connected to a PC via a conventional RS232 cable. The module should be switched off and the power supply interrupted to do this. After connecting, you can insert the power plug again and send or receive data via RS232. As every neMESYS syringe pump contains a RS232 to CAN gateway, all connected modules may be controlled via only one RS232 cable connection. The following communication settings should be used for the serial connection, whether at your PC or at another controller:

- Baud rate: 115200
- Data bits: 8
- Parity: none

- Stop bits: 1
- Flow control: none



ATTENTION. Danger due to damaged cables and connectors! Regularly check the device and all cables for damages! Never operate a device with damaged cables or connectors! Only use supplied original cables!



ATTENTION. Danger of tripping over power and connecting cables! Always place cables such as to avoid any danger of tripping!

6 Operating the Hardware

6.1 Syringes

The neMESYS Ultra High Pressure module must only be used with those syringes that have been developed especially for this module; other syringes may not withstand the forces applied by the pump during operation. This may cause damages to the syringes and the module or injuries to the operator.



ATTENTION. Use the neMESYS Ultra High Pressure only with one of the exclusive syringes especially developed for it by CETONI GmbH.

6.1.1 Maintenance of the Syringes

The maintenance of the syringes, such as the disassembly and the change of the seals is treated in the accompanying syringe manual.



IMPORTANT. Please read the corresponding syringe manual before using the syringes.

6.1.2 Syringe Configuration

The syringes for the neMESYS Ultra High Pressure module are preconfigured in the software. If your syringe is not available in this selection, for instance because it is newer than the software version, you must configure it. Only this will ensure that the flow rates and dosed volumes shown by the software are equivalent to the actual values, respectively; it also prevents mechanical damages due to wrong stroke distances. The correct procedure to configure syringes is described in detail in the accompanying software manual; please proceed as described therein. The data and values that you require for syringe configuration can be found in the syringe manual.

6.1.3 Installation on the Device

1. Perform a reference move as described in the software manual. This is to calibrate the position of the piston holder. This ensures that the syringe volume will be optimally utilized and that no collision and thus damage to the syringe or the module will occur during operation.



CAUTION. Carry out a reference move before mounting a syringe. This ensures optimal use of the syringe volume and avoids potential damages to syringe and module.

Now, use the software to move the piston holder to a position appropriate for mounting the syringe. Next, remove the safety cover by pulling at its distant end (as shown in the picture below) until the cover is released.

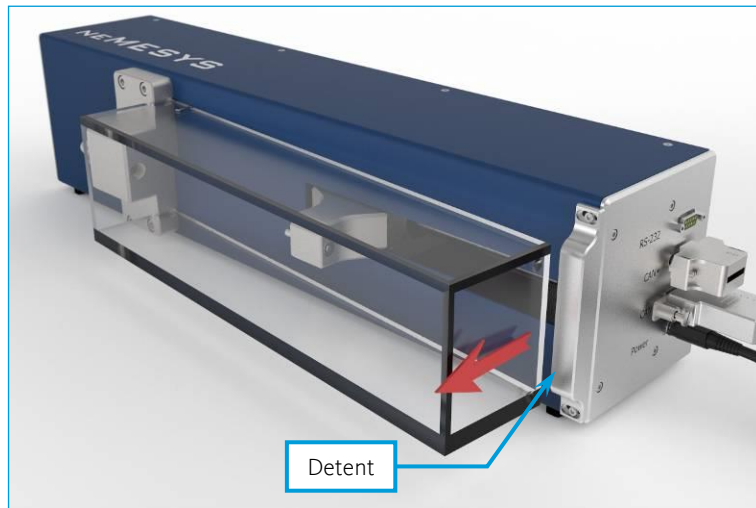

2. To establish a leak-tight connection between the syringe and syringe holder, a metal seal ring is used. Place the metal seal ring into the tapped hole of the syringe holder and screw in the syringe by hand until it stops.

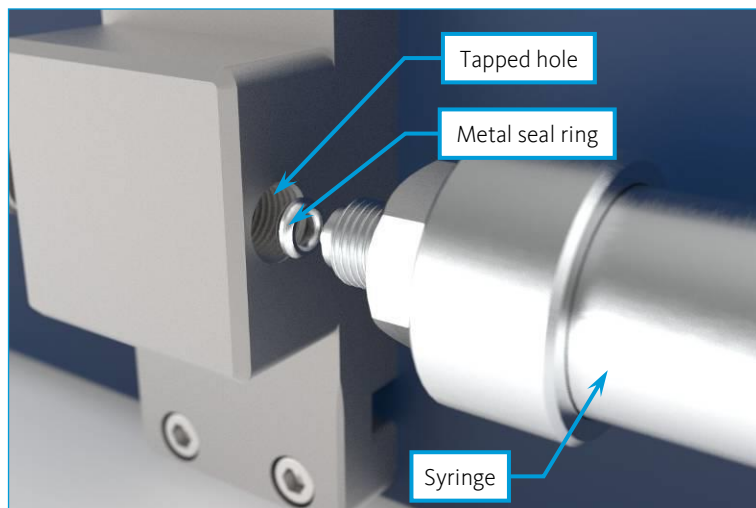

3. The syringes for the neMESYS Ultra High Pressure module have a 24mm hex directly behind the threaded tip. Use a 24 mm open-end wrench and tighten the syringe by another half to three-quarters turn.

If you remove the syringe and install it again later, after the finger tightening the syringe another quarter turn is sufficient for a tight connection.

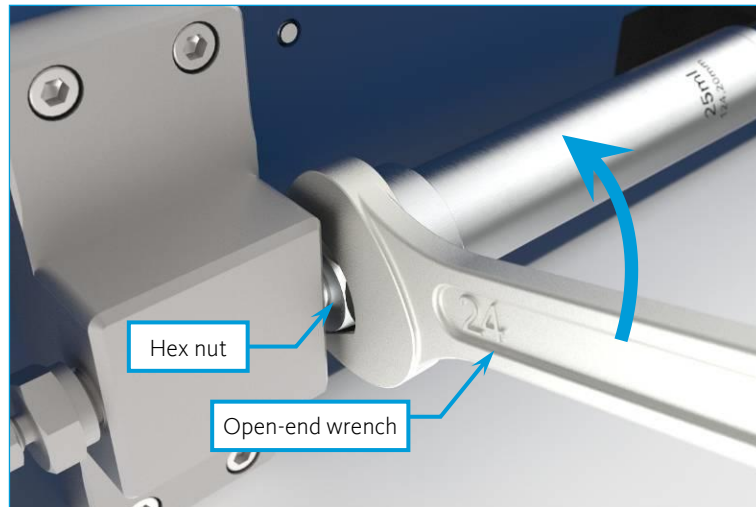

Assembly / Disassembly

4. Connect the syringe piston to the piston holder using the supplied socket head screw. Tighten the screw using a 4 mm Allen key.

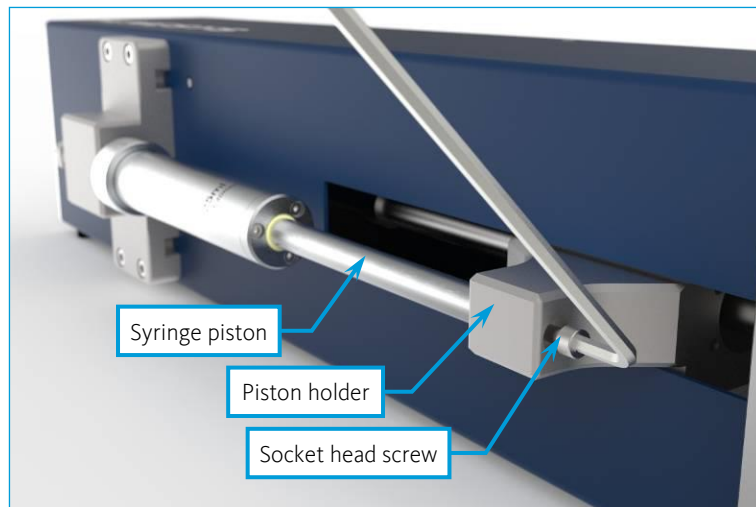

Mounting of the piston holder

5. Then set the safety cover back on the device. To do this, insert the two hooks of the cover into the recesses of the syringe holder and press the cover back into the detent.



Mounting the hood



CAUTION. When used over extended periods of time, the syringe may display wear. Please check the condition of the syringe regularly and exchange the seals or the syringe as required.



CAUTION. Please ensure that the device has been stopped using the software prior to mounting or exchanging syringes.

6.2 Fluidic Connection

On the outlet side the syringe holder provides a connection for high-pressure tubing with 1/4" outer diameter. This is necessary because ordinary tube fittings cannot withstand the high pressure of 890 bar, that can be achieved, using the 10 ml syringe. The high pressure connection on the other hand is approved for a pressure of 1550 bar.

In order to use thinner tubing, if you work with syringes, which do not produce such a high pressure, the device is supplied with a reducer union for 1/8" tubing.

The operation of the two fittings is explained below.



CAUTION. Make sure that the tubing and connection technology, you want to use, are suitable for the expected pressures.

6.2.1 High Pressure Connection (for 10 ml Syringe)

The high pressure connection is designed for the use of high-pressure tubing with an outer diameter of 1/4". Therefore the end of the tubing must be provided with a 58° cone and a 1/4"-28 UNF left-hand-thread. The exact specifications can be found in the following drawing:

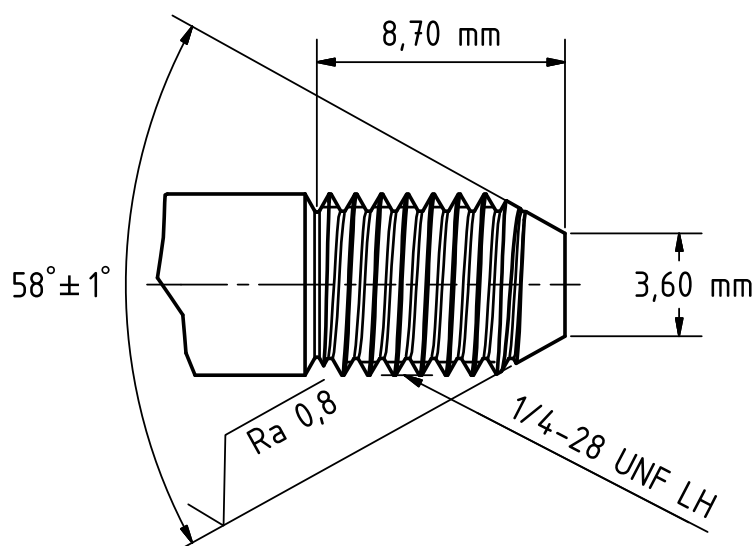

Tubing that is already provided with this kind of end machining can be ordered in different lengths directly from MAXIMATOR GmbH, or from CETONI. The same applies to a hand tool for making the cone and a hand tool for threading. The respective order numbers of MAXIMATOR GmbH can be found in the following table:

ROHRLÄNGE [mm/ (Zoll)]	BESTELLNUMMER
69,85 / (2,75)	21N4M-2.75-316
76,2 / (3)	21N4M-3-316
101,6 / (4)	21N4M-4-316
152,4 / (6)	21N4M-6-316
203,2 / (8)	21N4M-8-316
254 / (10)	21N4M-10-316
304,8 / (12)	21N4M-12-316
KONUSWERKZEUG	CT4M
GEWINDESCHNEIDER	TT4

For installation of the tube, slide the gland onto the prepared tube and then screw the collar on. Keep in mind that you must rotate the pressure ring counterclockwise due to the left-hand thread.

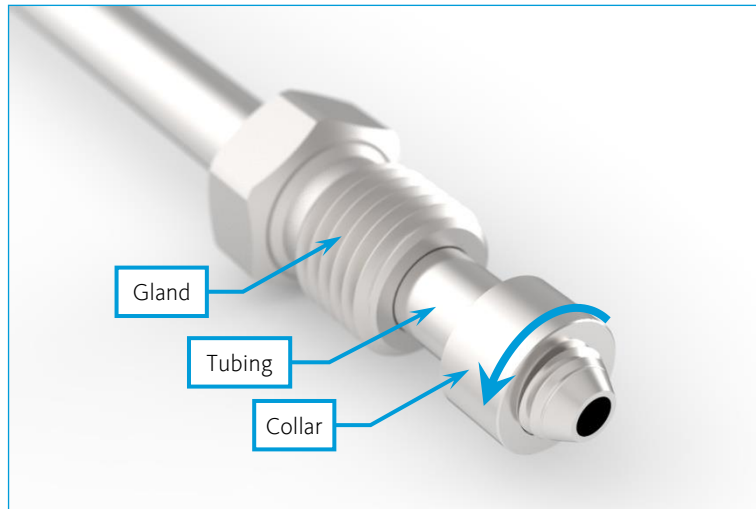

Insert the tubing with the collar into the tapped bore of the syringe holder and tighten the gland by hand until it stops. Use a 1/2" open-end wrench and tighten the syringe by another half to three-quarters turn.

After the installation is completed, check the leak tightness of the connection and pull the gland a little tighter if liquid emerges from the overload bore.

If you remove the connection and install it again later, after the finger tightening the connection another quarter turn is sufficient for a tight connection.

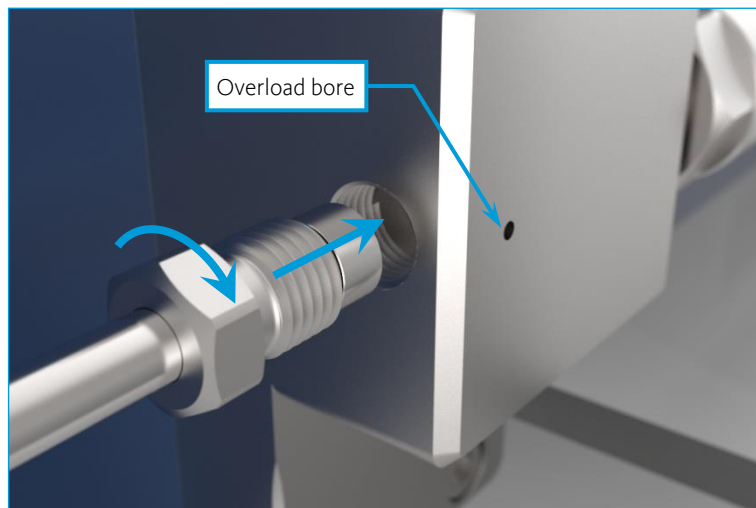

6.2.2 Reducer Union

In order to use thinner tubing, if you work with syringes, which do not produce such a high pressure, the device is supplied with a Swagelok reducer union for 1/8" tubing. It is suitable for using capillaries made from metal (e.g. stainless steel, titanium) and plastic (e.g. PTFE, PEEK). Please refer to information provided by the respective manufacturer with respect to maximum pressure. The operation of the reducer union is explained below:

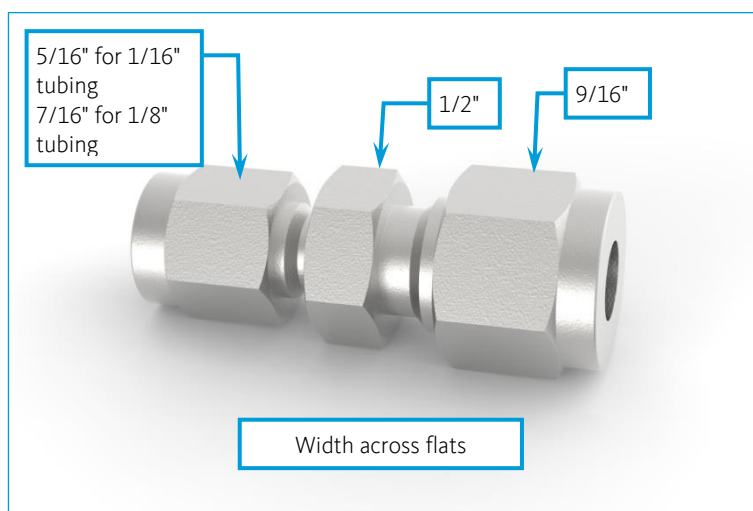

6.2.2.1 FIRST-TIME INSTALLATION

1. Fully insert the capillary into the fitting and against the shoulder. Then rotate the cap nut finger-tight.
2. Mark the cap nut at the 6 o'clock position.
3. Tighten the cap nut three-quarters turn to the 3 o'clock position with an open-end wrench while holding backup on the body of the union with a second wrench.

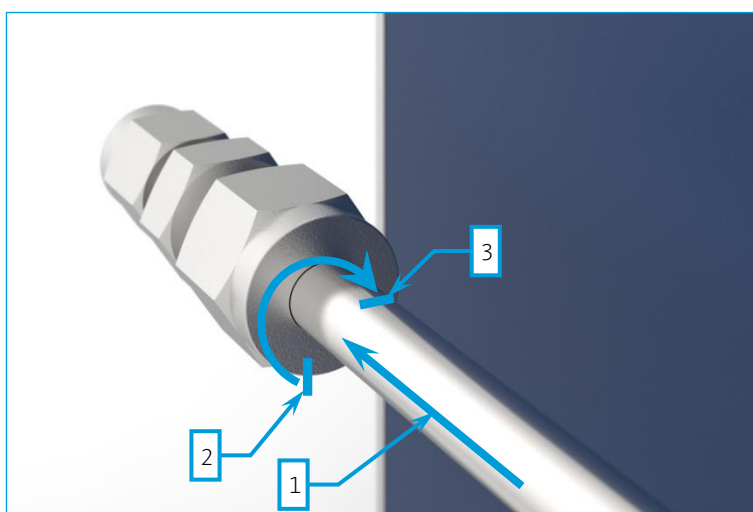

6.2.2.2 DISASSEMBLY



CAUTION. Release pressure from the system before loosening the fittings.

1. Before disassembly, draw a marker line across the cap nut and the body of the union. In this way you create a reference for retightening the cap nut to exactly the same position it was in before.
2. Pull out the capillaries. The cap nut and the ferrules remain on the capillary.

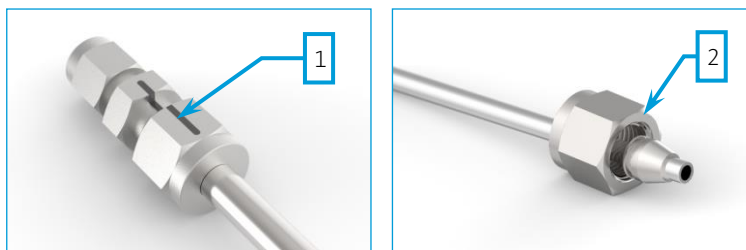

6.2.2.3 REASSEMBLY

1. To reassemble, insert the capillary with preassembled ferrules into the fitting body until the front ferrule seats against the fitting body.
2. Rotate the nut with open-end wrench to the previously pulled-up position as indicated by the marks you made before; at this point you will feel a significant increase in resistance.
3. Retighten the nut slightly. Done!



CAUTION. After (re-)connecting, check the tightness of all fluidic connections on a regular basis.

6.3 Signal interface

The neMESYS Ultra High Pressure module is equipped with an accessory port or The additional port allows the use of a pressure sensor, for example.



The pin assignment of the connector at the module can be found in the following table. Of course, you can also purchase ready-made periphery devices from CETONI GmbH.

A matching connector plug is also available from Hirose (order number HR10A-10P-12P(73)).



IMPORTANT. The configuration of pressure sensors is described in the software manual. Read and observe the relevant section before connecting a pressure sensor.



PIN	SIGNAL	DESCRIPTION		
1	Analog Input 1	12 bit 0 - 10 V		
2	Analog Input 2	12 bit 0 - 10 V		
3	Digital Input 1	<5 V (<1 mA) ≙ Low	>9 V (>3 mA) ≙ High	30 V max.
4	Digital Input 2	<5 V (<1 mA) ≙ Low	>9 V (>3 mA) ≙ High	30 V max.
5	reserved			
6	Digital Output 1	NPN (active low)	Aktive = 0 V	Inaktive = 24 V (Ri= 22kΩ)
7	Digital Output 2	NPN (active low)	Aktive = 0 V	Inaktive = 24 V (Ri= 22kΩ)
8	Digital Output 3	NPN (active low)	Aktive = 0 V	Inaktive = 24 V (Ri= 22kΩ)
9	Digital Ground			
10	+24 V Out	+24 VDC / <1 A		
11	+5 V Out	+5 VDC / <150 mA		
12	Analog Ground			

6.4 Overload Clutch

In order to avoid an overload of the neMESYS Ultra High Pressure module and the syringes, the module features an overload clutch. The clutch is designed so that the maximum pressures specified in the data sheet are reached. When the allowed driving force is exceeded, the clutch disconnects the drive from the piston holder and switches off the drive.

The clutch is purely a safety measure – it is not a substitute for a pressure sensor!



CAUTION. You should use a pressure sensor in all your applications to avoid dangerous situations. The built-in overload clutch is only there as a safety device in case of errors or faults.

6.4.1 Overload Procedure

1. Make sure to remove the cause for the overload.
2. Following an overload interrupt, the overload clutch may re-engage automatically; the module may then directly be controlled again via the software. If this is the case, please continue with step 4.
3. In some cases, the overload clutch will not re-engage automatically and the module must be reset manually. For this, there is a push button behind a small hole at the front plate of the module.



Push and hold the button using a thin object (wire, pin) to bridge the clutch sensor and to allow operation of the module. Now carefully build up a pressure by setting a very low flow rate until the clutch re-engages – you will hear a clear 'clack' sound.

4. Due to the separation of drive and piston holder, the real position of the piston holder may deviate from that stored in the software. In order to reset the module, perform a reference move using the software. Following this recalibration, the module is again ready to be used.



CAUTION. To avoid another case of system overload, the reference move should be carried out with the syringe removed from the module.

6.5 Valve Interface

The neMESYS Ultra High Pressure module also features a valve interface. It is located on the front plate of the module and allows the direct control of a high-pressure valve unit. Please refer to the valve's manual on how to connect and operate the valve.

7 Transport and Storage

Use the original packaging for transportation or shipping of the module.

Concerning the storage conditions, please observe the data from chapter 4.1.



CAUTION. Transportation, storage or operation of the modules below 0°C with water in the fluid passages may cause damage to the module.

8 Maintenance and Care

If used in accordance with intended purpose, the device is maintenance-free. Should there be a failure despite this, which you cannot eliminate yourself, or which requires opening the device, please contact CETONI GmbH to coordinate further actions. The device may only be opened by CETONI GmbH or thereby authorized service staff. Otherwise the warranty and guarantee claims are void.

Software-related troubles are dealt with in the Software Manual.

For cleaning it please rub the surface gently with a soft, damp cloth. The cloth must not be wet, so that no fluency can trickle into the device. In case of a heavier soiling you can also use a little bit of detergent or alcohol.

9 Disposal

Please return your old devices to CETONI GmbH which will ensure correct disposal according to the Electrical and Electronic Equipment Act.

Please decontaminate the device if necessary and include the completed Declaration of Decontamination form.