

**YGMOS Technology Crop.**

20V N-Channel Enhancement-Mode MOSFET 20V N 沟道增强型 MOS 管

**VDS = 20V**
**RDS(ON), Vgs@2.5V, Ids@5.2A = 40mΩ**
**RDS(ON), Vgs@4.5V, Ids@6A = 30mΩ**
**Features 特性**

Advanced trench process technology 高级的加工技术

High Density Cell Design For Ultra Low On-Resistance 极低的导通电阻高密度的单元设计

High Power and Current handling capability 大功率高电流

Ideal for Li ion battery pack applications 锂电池的理想选择

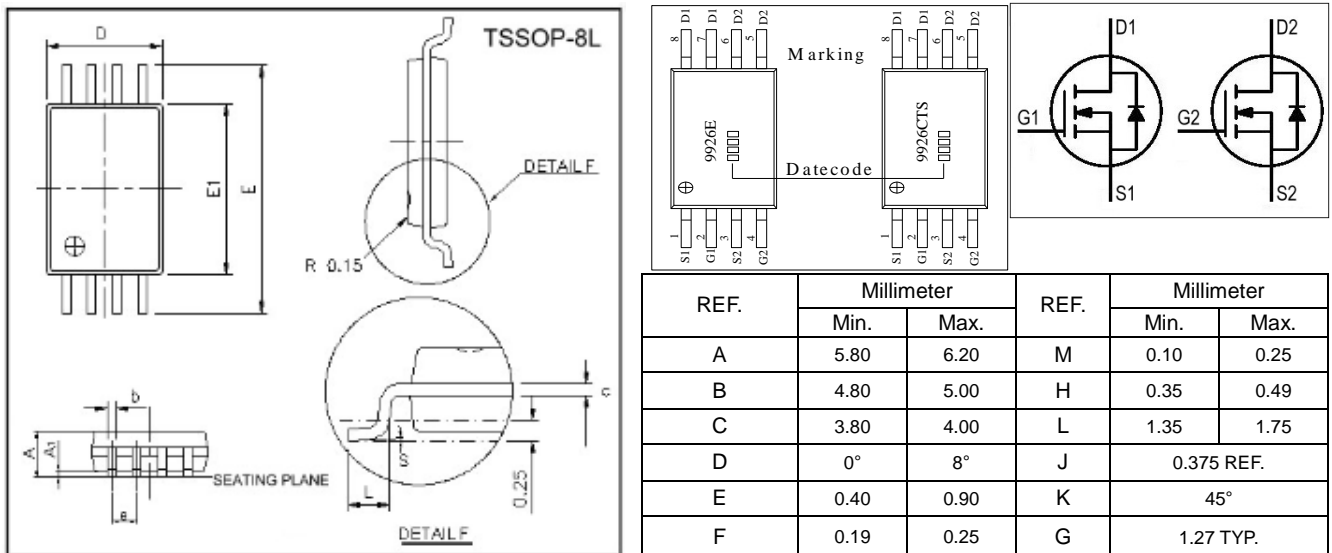
**Package Dimensions 封装尺寸及外形图**

**Maximum Ratings and Thermal Characteristics (TA = 25°C unless otherwise noted) 25°C 极限参数和热特性**

Parameter 极限参数	Symbol 符号	Limit 范围	Unit 单位	
Drain-Source Voltage 漏源电压	V <sub>DS</sub>	20	V	
Gate-Source Voltage 栅源电压	V <sub>GS</sub>	± 12		
Continuous Drain Current 连续漏极电流	I <sub>D</sub>	6	A	
Pulsed Drain Current 脉冲漏极电流	I <sub>DM</sub>	20		
Maximum Power Dissipation 最大耗散功率	P <sub>D</sub>	TA = 25°C	2	W
		TA = 75°C	1.28	
Operating Junction and Storage Temperature Range 使用及储存温度	T <sub>J</sub> , T <sub>stg</sub>	-55 to 150	°C	
Junction-to-Ambient Thermal Resistance (PCB mounted) 结环热阻	R <sub>θJA</sub>	62.5	°C/W	

**YGMOS Technology Crop.**
**ELECTRICAL CHARACTERISTICS** 一般电气特性

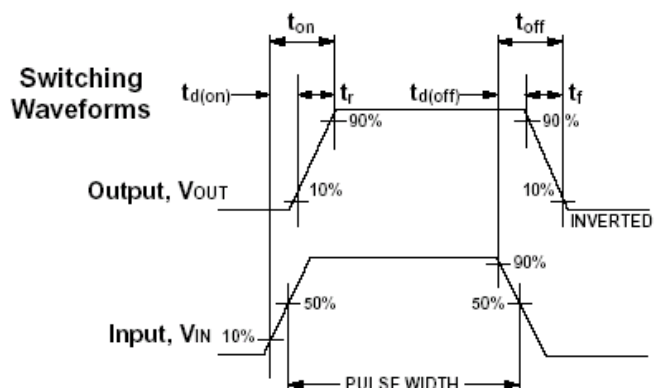
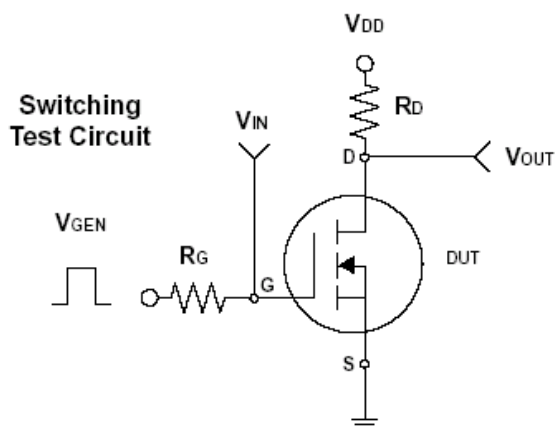
Parameter 参数	符号	Test Condition 测试条件	最小值	典型值	最大值	单位
<b>Static 静态参数</b>						
Drain-Source Breakdown Voltage 漏源击穿电压	$BV_{DSS}$	$V_{GS} = 0V, I_D = 250\mu A$	20	-	-	V
Drain-Source On-State Resistance 漏源导通电阻	$R_{DS(on)}$	$V_{GS} = 2.5V, I_D = 5.2A$		32.0	40.0	m $\Omega$
Drain-Source On-State Resistance 漏源导通电阻	$R_{DS(on)}$	$V_{GS} = 4.5V, I_D = 6A$		23.0	30.0	
Gate Threshold Voltage 开启电压	$V_{GS(th)}$	$V_{DS} = V_{GS}, I_D = 250\mu A$	0.6		1.2	V
Zero Gate Voltage Drain Current 零栅压漏极电流	$I_{DSS}$	$V_{DS} = 20V, V_{GS} = 0V$			1	$\mu A$
Gate Body Leakage 漏极短路时截止栅电流	$I_{GSS}$	$V_{GS} = \pm 12V, V_{DS} = 0V$			$\pm 100$	nA
Forward Transconductance 正向跨导	$g_{fs}$	$V_{DS} = 10V, I_D = 6A$		5	—	S
<b>Dynamic 动态参数</b>						
Total Gate Charge 栅极总电荷	$Q_g$	$V_{DS} = 10V, I_D = 6A$ $V_{GS} = 4.5V$		5	7	nC
Gate-Source Charge 栅-源极电荷	$Q_{gs}$			1		
Gate-Drain Charge 栅-漏极电荷	$Q_{gd}$			1.5		
Turn-On Delay Time 导通延迟时间	$t_{d(on)}$	$V_{DD} = 10V, R_G = 6\Omega$ $I_D = 1A, V_{GS} = 4.5V$		8	20	ns
Turn-On Rise Time 导通上升时间	$t_r$			10	20	
Turn-Off Delay Time 关断延迟时间	$t_{d(off)}$			22	45	
Turn-Off Fall Time 关断下降时间	$t_f$			6	15	
Input Capacitance 输入电容	$C_{iss}$	$V_{DS} = 8V, V_{GS} = 0V$ $f = 1.0\text{ MHz}$		565		pF
Output Capacitance 输出电容	$C_{oss}$			105		
Reverse Transfer Capacitance 反向传输电容	$C_{rss}$			75		
<b>Source-Drain Diode 源漏二极管参数</b>						
Max. Diode Forward Current 最大正向电流	$I_S$				1.7	A
Diode Forward Voltage 正向电压	$V_{SD}$	$I_S = 1.7A, V_{GS} = 0V$			1.2	V

 Note: Pulse test: pulse width  $\leq 300\mu s$ , duty cycle  $\leq 2\%$  注意: 脉冲测试: 脉冲宽度  $\leq 300\mu s$  死区  $\leq 2\%$ 

**YGMOS Technology Corp.**
**Typical Characteristics (T<sub>J</sub> = 25°C Noted)**
