

YGMOS Technology Crop.

100V N Channel Enhancement Mode MOSFET 100 V N 沟道增强型 MOS 管

VDS= 100V

RDS(ON), Vgs@10V, Ids@1.6A = 135mΩ

RDS(ON), Vgs@5.0V, Ids@1.3A = 175mΩ

Features 特性

Advanced trench process technology 高级的加工技术

High Density Cell Design For Ultra Low OnResistance

极低的导通电阻高密度的单元设计

Improved ShootThrough FOM 改进的成型工艺

Package Dimensions 封装尺寸及外形图

Package Dimensions 封装尺寸及外形图

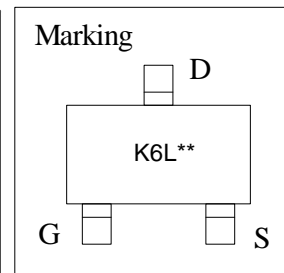
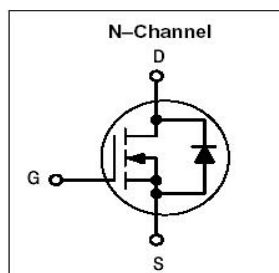
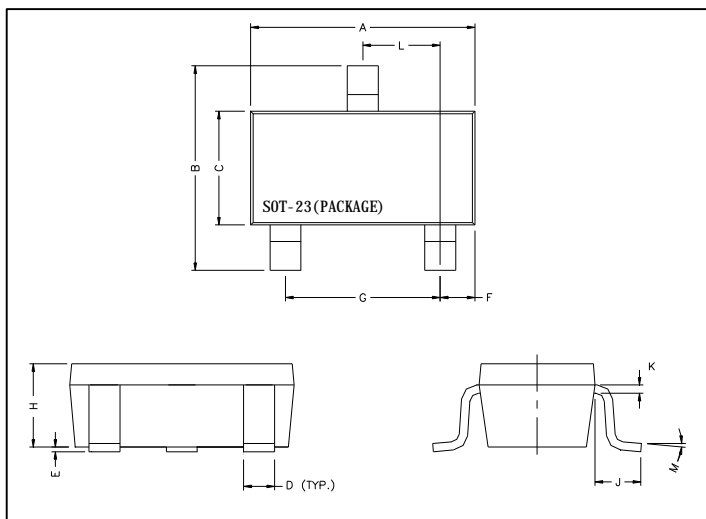

REF.	Millimeter		REF.	Millimeter	
	Min.	Max.		Min.	Max.
A	2.70	3.10	G	1.90	REF.
B	2.40	2.80	H	1.00	1.30
C	1.40	1.60	K	0.10	0.20
D	0.35	0.50	J	0.40	-
E	0	0.10	L	0.85	1.15
F	0.45	0.55	M	0°	10°

Maximum Ratings and Thermal Characteristics (TA = 25°C unless otherwise noted) 25°C 极限参数和热特性

Parameter 极限参数	Symbol 符号	Limit 范围	Unit 单位	
DrainSource Voltage 漏源电压	V _{DS}	100	V	
GateSource Voltage 栅源电压	V _{GS}	± 20		
Continuous Drain Current 连续漏极电流	I _D	1.6	A	
Pulsed Drain Current 脉冲漏极电流	I _{DM}	5		
Maximum Power Dissipation 最大耗散功率	P _D	TA = 25°C	1	W
		TA = 75°C	0.5	
Operating Junction and Storage Temperature Range 使用及储存温度	T _J , T _{stg}	-55 to 150	°C	
JunctiontoAmbient Thermal Resistance (PCB mounted) 结环热阻	R _{θJA}	125	°C/W	

YGMOS Technology Crop.

ELECTRICAL CHARACTERISTICS 一般电气特性

Parameter 参数	符号	Test Condition 测试条件	最小值	典型值	最大值	单位
Static 静态参数						
DrainSource Breakdown Voltage 漏源击穿电压	BV_{DSS}	$V_{GS} = 0V, I_D = 250\mu A$	100			V
DrainSource OnState Resistance 漏源导通电阻	$R_{DS(on)}$	$V_{GS} = 10V, I_D = 1.6A$		110	135	mΩ
DrainSource OnState Resistance 漏源导通电阻	$R_{DS(on)}$	$V_{GS} = 5.0V, I_D = 1.3A$		140	175	
Gate Threshold Voltage 开启电压	$V_{GS(th)}$	$V_{DS} = V_{GS}, I_D = 250\mu A$	2.0	2.9	4.0	V
Zero Gate Voltage Drain Current 零栅压漏极电流	I_{DSS}	$V_{DS} = 60V, V_{GS} = 0V$			1	μA
Gate Body Leakage 漏极短路时截止栅电流	I_{GSS}	$V_{GS} = \pm 20V, V_{DS} = 0V$			±100	nA
Forward Transconductance 正向跨导	g_{fs}	$V_{DS} = 5V, I_D = 1A$		2.4		S
Dynamic 动态参数						
Total Gate Charge 栅极总电荷	Q_g	$V_{DS} = 50V, I_D = 1.5A$ $V_{GS} = 4.5V$		6.2		nC
GateSource Charge 栅源极电荷	Q_{gs}			2.3		
GateDrain Charge 栅漏极电荷	Q_{gd}			4.2		
TurnOn Delay Time 导通延迟时间	$t_{d(on)}$	$V_{DD} = 50V, I_D = 1.5A$ $V_{GEN} = 4.5V, R_G = 6.8\Omega$		10		ns
TurnOn Rise Time 导通上升时间	t_r			11.5		
TurnOff Delay Time 关断延迟时间	$t_{d(off)}$			27		
TurnOff Fall Time 关断下降时间	t_f			2.5		
Input Capacitance 输入电容	C_{iss}	$V_{DS} = 25V, V_{GS} = 0V$ $f = 1.0MHz$		740		pF
Output Capacitance 输出电容	C_{oss}			56		
Reverse Transfer Capacitance 反向传输电容	C_{rss}			22.5		
SourceDrain Diode 源漏二极管参数						
Max. Diode Forward Current 最大正向电流	I_S				1.2	A
Diode Forward Voltage 正向电压	V_{SD}	$I_S = 1.0A, V_{GS} = 0V$			1.2	V

Note :

- 1.The data tested by surface mounted on a 1 inch² FR-4 board with 20Z copper.
- 2.The data tested by pulsed , pulse width $\leq 300\mu s$, duty cycle $\leq 2\%$
- 3.The power dissipation is limited by 150°C junction temperature
- 4.The data is theoretically the same as I_D and I_{DM} , in real applications , should be limited by total power dissipation.

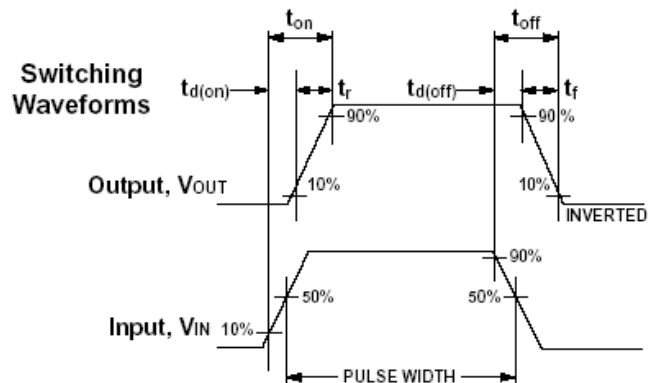
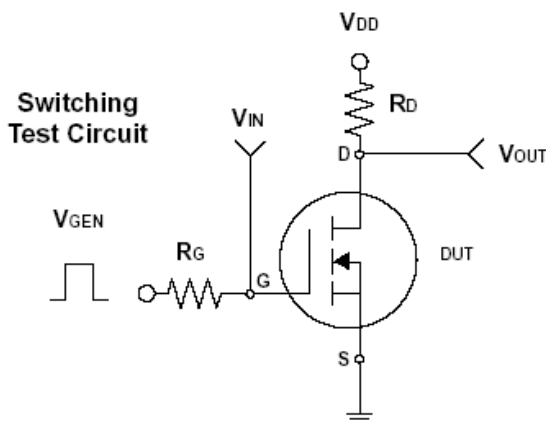

YGMOS Technology Crop.

TYPICAL CHARACTERISTICS (25 °C, unless otherwise noted)

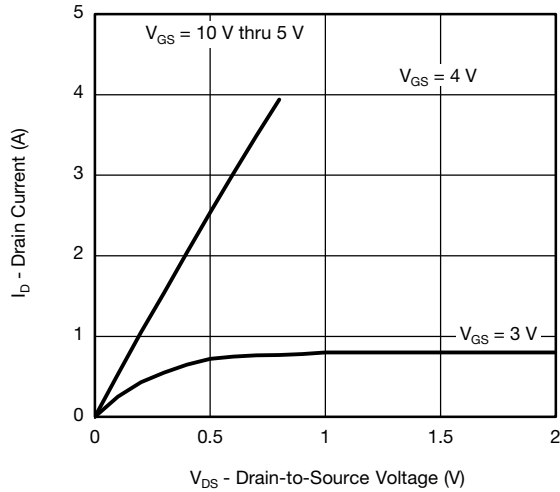

Output Characteristics

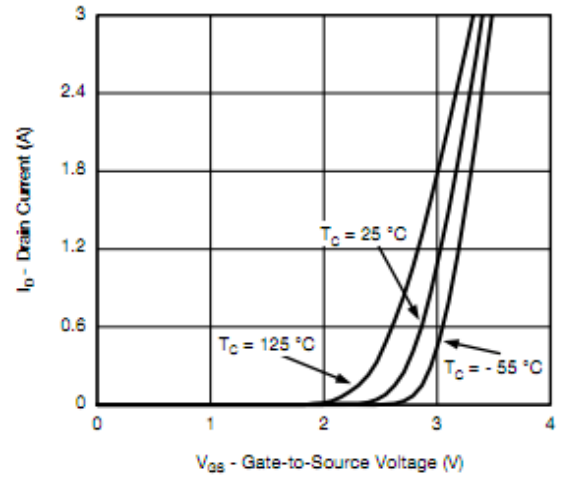

Transfer Characteristics

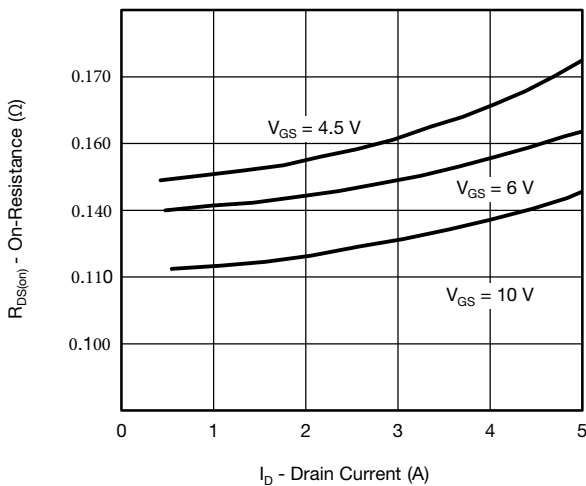

On-Resistance vs. Drain Current and Gate Voltage

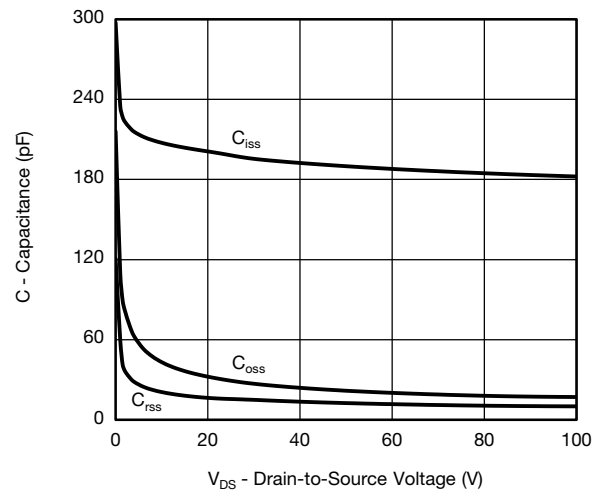

Capacitance

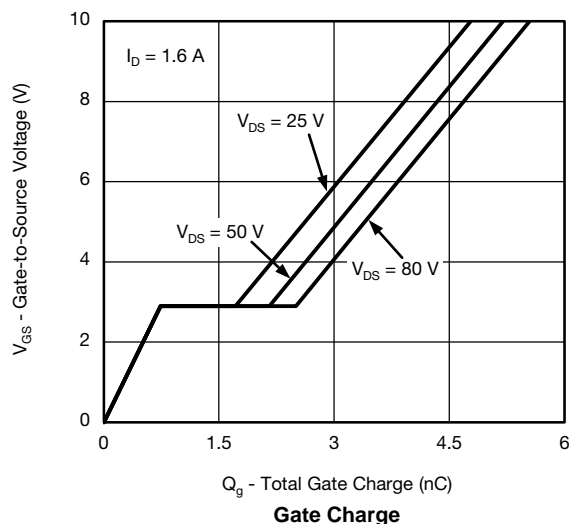

Gate Charge

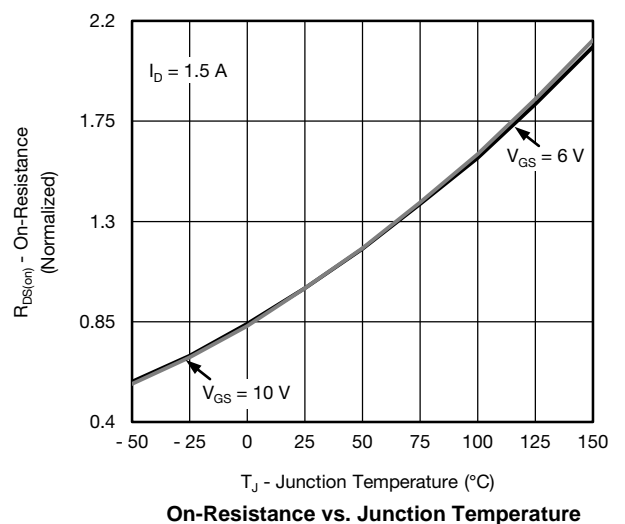

On-Resistance vs. Junction Temperature