

YGMOS Technology CO. LTD

-30V P-Channel Enhancement-Mode MOSFET

-30V P 沟道增强型 MOS 管

VDS≤-30V

RDS(ON), Vgs@-10V, Ids@-8A ≤ 10m Ω

RDS(ON), Vgs@-4.5V, Ids@-6A ≤ 15mΩ

Features 特性

Advanced trench process technology 高级的加工技术

High Density Cell Design For Ultra Low On-Resistance 极低的导通电阻高密度的单元设计

High Power and Current handling capability 大功率高电流

Package Dimensions

封装尺寸及外形图

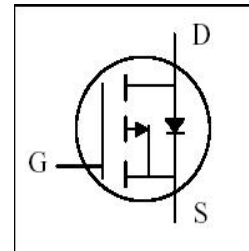
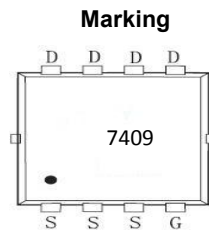
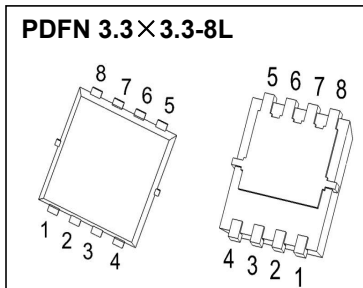

Maximum Ratings and Thermal Characteristics (TA = 25 °C unless otherwise noted) 25 °C 极限参数和热特性

Parameter 极限参数	Symbol 符号	Limit 范围	Unit 单位	
Drain-Source Voltage 漏源电压	V _{DS}	-30	V	
Gate-Source Voltage 栅源电压	V _{GS}	±20		
Continuous Drain Current 连续漏极电流	I _D	-30	A	
Pulsed Drain Current 脉冲漏极电流	I _{DM}	-100		
Maximum Power Dissipation 最大耗散功率	P _D	TA = 25 °C	55	W
		TA = 75 °C	38	
Operating Junction and Storage Temperature Range 使用及储存温度	T _J , T _{stg}	-55 to 150	°C	
Junction-to-Ambient Thermal Resistance (PCB mounted) 结环热阻	R _{qJA}	75	°C/W	
Junction-to-Case Thermal Resistance 结壳热阻	R _{qJC}	4.5		

YGMOS Technology CO. LTD

ELECTRICAL CHARACTERISTICS 一般电气特性						
Parameter 参数	Symbol 符号	Test Condition 测试条件	Minimum 最小值	Typical 典型值	Maximum 最大值	Unit 单位
Static 静态参数						
Drain-Source Breakdown Voltage 漏源击穿电压	BV_{DSS}	$V_{GS} = 0V, I_D = 250\mu A$	-30			V
Drain-Source On-State Resistance 漏源导通电阻	$R_{DS(on)}$	$V_{GS} = -10V, I_D = -8A$		8.1	10	m Ω
Drain-Source On-State Resistance 漏源导通电阻	$R_{DS(on)}$	$V_{GS} = -4.5V, I_D = -6A$		12	15	
Gate Threshold Voltage 开启电压	$V_{GS(th)}$	$V_{DS} = V_{GS}, I_D = 250\mu A$	-1	-1.3	-3	V
Zero Gate Voltage Drain Current 零栅压漏极电流	I_{DSS}	$V_{DS} = -24V, V_{GS} = 0V$			-1	μA
Gate Body Leakage 漏极短路时截止栅电流	I_{GSS}	$V_{GS} = \pm 20V, V_{DS} = 0V$			± 100	nA
Dynamic 动态参数						
Total Gate Charge 栅极总电荷	Q_g	$V_{DS} = -15V, I_D = -1.5A$ $V_{GS} = 10V$		82		nC
Gate-Source Charge 栅-源极电荷	Q_{gs}			6.8		
Gate-Drain Charge 栅-漏极电荷	Q_{gd}			9.6		
Turn-On Delay Time 导通延迟时间	$t_{d(on)}$	$V_{DD} = -15V, R_L = 15\Omega$ $I_D = -1A, V_{GEN} = -10V$ $R_G = 6\Omega$		11.7		ns
Turn-On Rise Time 导通上升时间	t_r			14.4		
Turn-Off Delay Time 关断延迟时间	$t_{d(off)}$			146		
Turn-Off Fall Time 关断下降时间	t_f			36.6		
Input Capacitance 输入电容	C_{iss}	$V_{DS} = -15V, V_{GS} = 0V$ $f = 200KHz$		4053		pF
Output Capacitance 输出电容	C_{oss}			433		
Reverse Transfer Capacitance 反向传输电容	C_{rss}			370		
Source-Drain Diode 源漏二极管参数						
Max. Diode Forward Current 最大正向电流	I_S				-2.5	A
Diode Forward Voltage 正向电压	V_{SD}	$I_S = -2.1A, V_{GS} = 0V$			-1.2	V

Note: Pulse test: pulse width $\leq 300\mu s$, duty cycle $\leq 2\%$ 注意: 脉冲测试: 脉冲宽度 $\leq 300\mu s$ 死区 $\leq 2\%$

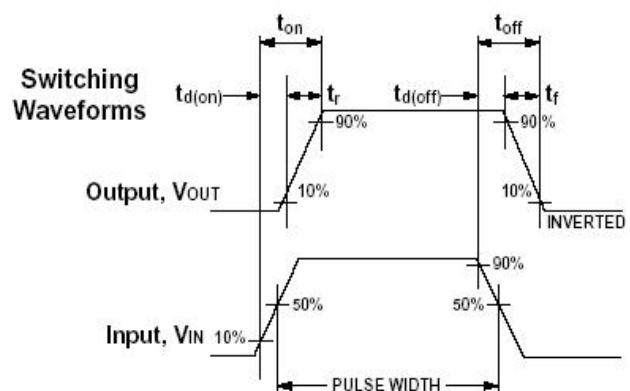
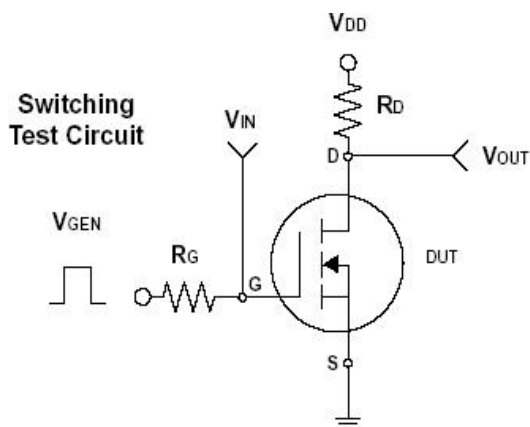

YG MOS Technology CO. LTD

PDFN 3.3*3.3-8L Package Outline Dimensions

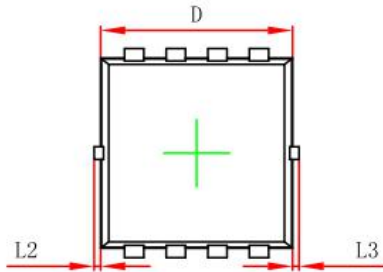

Top View
[顶视图]

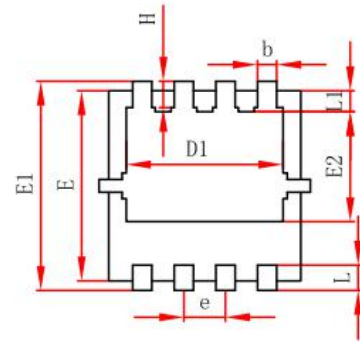

Bottom View
[背视图]

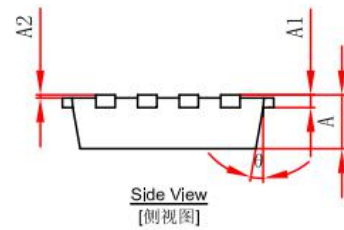
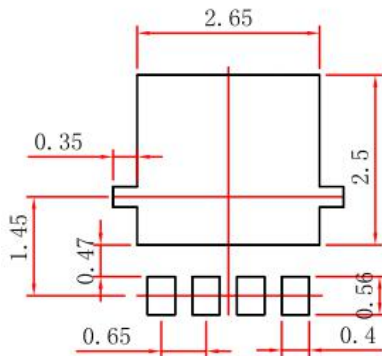

Side View
[侧视图]

Symbol	Dimensions In Millimeters		Dimensions In Inches	
	Min.	Max.	Min.	Max.
A	0.650	0.850	0.026	0.033
A1	0.152 REF.		0.006 REF.	
A2	0~0.05		0~0.002	
D	2.900	3.100	0.114	0.122
D1	2.300	2.600	0.091	0.102
E	2.900	3.100	0.114	0.122
E1	3.150	3.450	0.124	0.136
E2	1.535	1.935	0.060	0.076
b	0.200	0.400	0.008	0.016
e	0.550	0.750	0.022	0.030
L	0.300	0.500	0.012	0.020
L1	0.180	0.480	0.007	0.019
L2	0~0.100		0~0.004	
L3	0~0.100		0~0.004	
H	0.315	0.515	0.012	0.020
θ	9°	13°	9°	13°