

# Servomech Screw Jack SJ Series

## Screw jacks SJ Series

### Screw jacks SJ Series with travelling screw (Mod.A) STRUCTURAL ELEMENTS

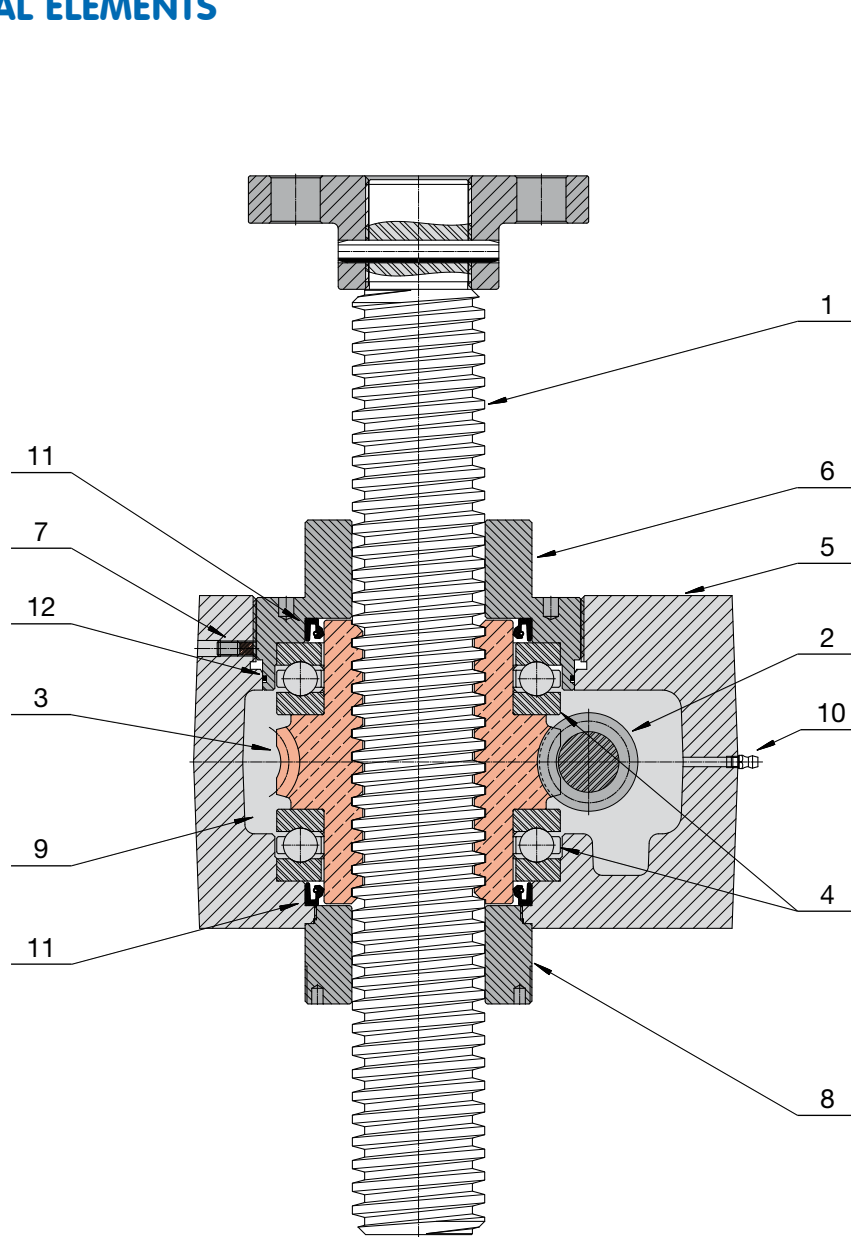

3

- 1 - acme screw in steel C 43 (UNI 7847), rolled or whirled thread
- 2 - worm shaft with true involute, ground worm profile ZI (UNI 4760), made in steel, case-hardened
- 3 - bronze wormwheel with internal nut, toothing with true involute profile ZI (UNI 4760)
- 4 - thrust ball bearing for high load capacity
- 5 - monoblock gear box
- 6 - threaded cover with guide for acme screw; may be used as a spigot diameter
- 7 - grub screw which prevents the threaded cover unscrewing
- 8 - guide for acme screw; may be used as a spigot diameter
- 9 - long-life synthetic grease lubricated worm gearbox
- 10 - grease nipple
- 11 - radial lubricant seal
- 12 - O-Ring as lubricant seal

# Screw jacks SJ Series

## Screw jacks SJ Series with travelling nut (Mod.B) STRUCTURAL ELEMENTS

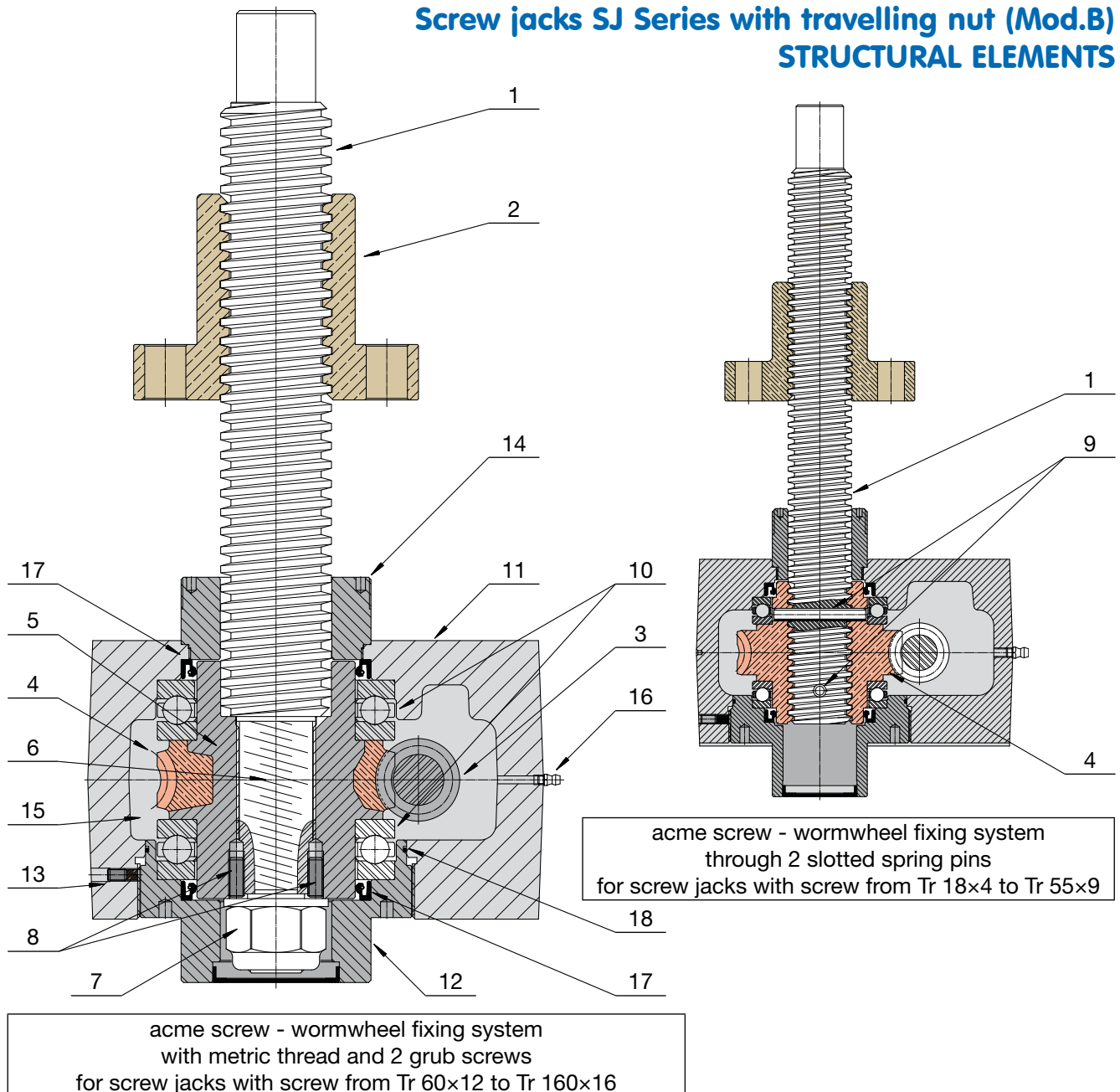

acme screw - wormwheel fixing system  
through 2 slotted spring pins  
for screw jacks with screw from Tr 18x4 to Tr 55x9

acme screw - wormwheel fixing system  
with metric thread and 2 grub screws  
for screw jacks with screw from Tr 60x12 to Tr 160x16

- 1 - acme screw in steel C 43 (UNI 7847), whirled thread
- 2 - bronze travelling nut with flange
- 3 - worm shaft with true involute, ground worm profile ZI (UNI 4760), made in steel, case-hardened
- 4 - bronze wormwheel with true involute profile ZI (UNI 4760)
- 5 - cast iron support of the wormwheel bronze rim
- 6 - acme screw fixed to the wormwheel through LEFT-HAND (for push load) or RIGHT-HAND (for pull load) metric thread
- 7 - lock nut with the opposite direction metric thread to ensure safe acme screw fixing
- 8 - acme screw – wormwheel pins against unscrewing
- 9 - slotted spring pin
- 10 - thrust ball bearing for high load capacity
- 11 - monoblock gear box
- 12 - threaded cover with guide for acme screw; may be used as a spigot diameter
- 13 - grub screw which prevents the threaded cover unscrewing
- 14 - guide for acme screw; may be used as a spigot diameter
- 15 - long-life synthetic grease lubricated worm gearbox
- 16 - grease nipple
- 17 - radial lubricant seal
- 18 - O-Ring as lubricant seal

## Screw jacks SJ Series

### Screw jacks SJ Series with 1-start acme screw TECHNICAL SPECIFICATIONS

SCREW JACK SIZE		SJ 5	SJ 10	SJ 25	SJ 50	SJ 100	SJ 150	SJ 200	
Load capacity [kN], (push - pull)		5	10	25	50	100	150	200	
1-start acme screw		Tr 18x4	Tr 22x5	Tr 30x6	Tr 40x7	Tr 55x9	Tr 60x12	Tr 70x12	
Worm gear centre distance [mm]		25	30	50	63	63	80	90	
Available ratio	RH	1 : 4 (5 : 20)	—	—	—	—	—	—	
	RV	1 : 6.25(4 : 25)	1 : 4 (4 : 16)	1 : 6 (4 : 24)	1 : 7 (4 : 28)	1 : 7 (4 : 28)	1 : 8 (4 : 32)	1 : 7 (4 : 28)	
	RN	1 : 12.5(2 : 25)	1 : 16 (2 : 32)	1 : 18 (2 : 36)	1 : 14 (2 : 28)	1 : 14 (2 : 28)	1 : 24	—	
	RL	1 : 25	1 : 24	1 : 24	1 : 28	1 : 28	1 : 32	1 : 28	
Stroke [mm] for 1 input shaft revolution	Ratio	RH1	1	—	—	—	—	—	
		RV1	0.64	1.25	1	1	1.28	1.5	1.71
		RN1	0.32	0.31	0.33	0.5	0.64	0.5	—
		RL1	0.16	0.21	0.25	0.25	0.32	0.375	0.43
Starting efficiency	Ratio	RH1	0.25	—	—	—	—	—	
		RV1	0.25	0.26	0.20	0.18	0.20	0.20	0.19
		RN1	0.21	0.20	0.16	0.15	0.17	0.13	—
		RL1	0.16	0.16	0.13	0.11	0.13	0.12	0.12
Running efficiency at 1500 rpm <sup>(1)</sup>	Ratio	RH1	0.35	—	—	—	—	—	
		RV1	0.34	0.36	0.34	0.32	0.33	0.36	0.36
		RN1	0.29	0.28	0.27	0.28	0.29	0.29	—
		RL1	0.25	0.25	0.25	0.23	0.24	0.26	0.25
Starting torque on input shaft at max. load [Nm]	Ratio	RH1	3.8	—	—	—	—	—	
		RV1	2.5	9	20	44	77	120	325
		RN1	1.7	3.5	8.3	25	47	62	—
		RL1	1	2.5	7.6	18	34	50	125
Max. permissible operating power [kW] <sup>(2)</sup>	Ratio	RH1	0.40	—	—	—	—	—	
		RV1	0.40	0.60	1.2	2.4	2.5	3	4
		RN1	0.20	0.30	0.7	1.7	1.8	2.6	—
		RL1	0.17	0.25	0.6	1.2	1.2	2.3	3.2
Reactive torque on acme screw (nut) required at max. load [Nm]		8	20	65	165	460	800	1 200	
Gear box material		casting in aluminium alloy EN 1706 - AC-AISi10Mg T6			casting in cast iron EN-GJL-250 (UNI EN 1561)				
Mass of screw jack without acme screw [kg]		1.5	2.3	10.4	25	35	55	75	
Mass for every 100 mm of acme screw [kg]		0.16	0.23	0.45	0.8	1.6	1.8	2.5	

<sup>(1)</sup> - efficiency figures at different input speed on page 61

<sup>(2)</sup> - THERMAL limit, referred to work with max. duty cycle 30 % over 10 min time period (20 % over 1 hour time period) at 25°C environment temperature

# Screw jacks SJ Series

## Screw jacks SJ Series with 1-start acme screw TECHNICAL SPECIFICATIONS

SJ 250	SJ 300	SJ 350	SJ 400	SJ 600	SJ 800	SJ 1000	SCREW JACK SIZE	
250	300	350	400	600	800	1000	Load capacity [kN], (push - pull)	
Tr 80x12	Tr 90x12	Tr 100x12	Tr 100x12	Tr 120x14	Tr 140x14	Tr 160x16	1-start acme screw	
90	110	110	140	140	200	200	Worm gear centre distance [mm]	
—	—	—	—	—	—	—	RH	
1 : 7 (4 : 28)	3 : 29	3 : 29	3 : 28	3 : 28	3 : 35	3 : 35	RV	
—	—	—	—	—	—	—	RN	
1 : 28	1 : 30	1 : 30	1 : 29	1 : 29	1 : 36	1 : 36	RL	
—	—	—	—	—	—	—	RH1	
1.71	1.24	1.24	1.29	1.5	1.2	1.37	RV1	
—	—	—	—	—	—	—	RN1	
0.43	0.4	0.4	0.41	0.48	0.39	0.44	RL1	
—	—	—	—	—	—	—	RH1	
0.17	0.15	0.13	0.13	0.13	0.12	0.11	RV1	
—	—	—	—	—	—	—	RN1	
0.11	0.09	0.09	0.08	0.08	0.08	0.07	RL1	
—	—	—	—	—	—	—	RH1	
0.35	0.31	0.29	0.30	0.31	0.28	0.28	RV1	
—	—	—	—	—	—	—	RN1	
0.24	0.22	0.21	0.21	0.21	0.21	0.19	RL1	
—	—	—	—	—	—	—	RH1	
360	350	450	540	960	1175	1675	RV1	
—	—	—	—	—	—	—	RN1	
138	175	225	270	485	605	860	RL1	
—	—	—	—	—	—	—	RH1	
4	8	8	15	17	20	25	RV1	
—	—	—	—	—	—	—	RN1	
3.2	6.5	6.5	12	14	17	22	RL1	
1 650	2 150	2 700	3 100	5 500	8 500	12 000	Reactive torque on acme screw (nut) required at max. load [Nm]	
casting in cast iron EN-GJL-250 (UNI EN 1561)			casting in steel Fe G 60 (UNI 4010)				Gear box material	
75	120	120	260	260	800	800	Mass of screw jack without acme screw [kg]	
3.4	4.4	5.5	5.5	7.9	10.9	14.2	Mass for every 100 mm of acme screw [kg]	

(<sup>1</sup>) - efficiency figures at different input speed on page 61

(<sup>2</sup>) - THERMAL limit, referred to work with max. duty cycle 30 % over 10 min time period (20 % over 1 hour time period)  
at 25°C environment temperature

# Screw jacks SJ Series - 1-start acme screw

Following tables show the screw jack LINEAR SPEED  $v$  [mm/s] and relative TORQUE  $T_1$  [Nm] and POWER  $P_1$  [kW] on input shaft, with reference to the INPUT SPEED  $n_1$  [rpm], the RATIO (RV, RN, RL) and the LOAD [kN] applied on the screw jack.

Intermediate values for linear speed  $v$ , torque  $T_1$  and power  $P_1$  at different input speed can be calculated by linear interpolation of the figures stated in the table.

The figures in the tables refer to work with max. duty cycle of 30 % over 10 min time period or 20 % over 1 hour time period at 25°C environment temperature.

**ATTENTION!** The figures in the **red shaded area** indicate operational restrictions due to thermal limits. When the selection is made within such area, the duty cycle must be reduced or the greater size screw jack must be selected, in order to allow effective heat dissipation. For a better evaluation, please contact SERVOMECH Engineering Dpt.

SJ 5					LOAD																							
					5 kN								3 kN								1 kN							
$n_1$ [rpm]	LINEAR SPEED $v$ [mm/s]				RATIO								RATIO								RATIO							
	RH1	RV1	RN1	RL1	RH1		RV1		RN1		RL1		RH1		RV1		RN1		RL1		RH1		RV1		RN1		RL1	
					$T_1$ Nm	$P_1$ kW	$T_1$ Nm	$P_1$ kW	$T_1$ Nm	$P_1$ kW	$T_1$ Nm	$P_1$ kW	$T_1$ Nm	$P_1$ kW	$T_1$ Nm	$P_1$ kW	$T_1$ Nm	$P_1$ kW	$T_1$ Nm	$P_1$ kW	$T_1$ Nm	$P_1$ kW	$T_1$ Nm	$P_1$ kW	$T_1$ Nm	$P_1$ kW	$T_1$ Nm	$P_1$ kW
1500	25	16	8	4	1.9	0.29	1.3	0.20	0.7	0.12	0.5	0.07	1.1	0.17	0.8	0.12	0.4	0.07	0.3	0.04	0.4	0.06	0.3	0.04	0.1	0.02	0.1	0.01
1000	16.7	10.7	5.3	2.7	2.0	0.21	1.4	0.14	0.8	0.09	0.5	0.05	1.2	0.12	0.8	0.09	0.5	0.05	0.3	0.03	0.4	0.04	0.3	0.03	0.2	0.02	0.1	0.01
750	12.5	8	4	2	2.1	0.16	1.4	0.11	0.8	0.07	0.5	0.04	1.3	0.10	0.8	0.07	0.5	0.04	0.3	0.03	0.4	0.03	0.3	0.02	0.2	0.01	0.1	0.01
500	8.3	5.3	2.7	1.3	2.3	0.12	1.5	0.08	0.9	0.05	0.6	0.03	1.4	0.07	0.9	0.05	0.5	0.03	0.3	0.02	0.5	0.02	0.3	0.02	0.2	0.01	0.1	0.01
300	5	3.2	1.6	0.8	2.4	0.08	1.6	0.05	1.0	0.03	0.6	0.02	1.5	0.05	1.0	0.03	0.6	0.02	0.4	0.01	0.5	0.02	0.3	0.01	0.2	0.01	0.1	0.01
100	1.7	1.1	0.5	0.3	2.8	0.03	2.0	0.02	1.1	0.01	0.7	0.01	1.7	0.02	1.2	0.01	0.7	0.01	0.4	0.01	0.6	0.01	0.4	0.01	0.2	0.01	0.1	0.01
50	0.8	0.5	0.3	0.1	3.1	0.02	2.0	0.01	1.2	0.01	0.7	0.01	1.8	0.01	1.2	0.01	0.7	0.01	0.4	0.01	0.6	0.01	0.4	0.01	0.2	0.01	0.1	0.01

SJ 10					LOAD																									
					10 kN						8 kN						6 kN						2 kN							
$n_1$ [rpm]	LINEAR SPEED $v$ [mm/s]				RATIO						RATIO						RATIO						RATIO							
	RV1	RN1	RL1	RV1	RN1	RL1	RV1	RN1	RL1	RV1	RN1	RL1	RV1	RN1	RL1	RV1	RN1	RL1	RV1	RN1	RL1	RV1	RN1	RL1	RV1	RN1	RL1	RV1	RN1	RL1
1500	31.3	7.8	5.2	5.6	0.87	1.8	0.28	1.3	0.21	4.4	0.70	1.4	0.22	1.1	0.17	3.3	0.52	1.1	0.17	0.8	0.13	1.1	0.17	0.4	0.06	0.3	0.04			
1000	20.8	5.2	3.5	5.8	0.63	1.8	0.19	1.4	0.15	4.7	0.49	1.5	0.15	1.1	0.12	3.5	0.37	1.1	0.12	0.8	0.09	1.2	0.12	0.4	0.04	0.3	0.03			
750	15.6	3.9	2.6	6.0	0.47	1.9	0.15	1.5	0.11	4.8	0.38	1.5	0.12	1.2	0.09	3.6	0.28	1.2	0.09	0.9	0.07	1.2	0.10	0.4	0.03	0.3	0.02			
500	10.4	2.6	1.7	6.4	0.34	2.0	0.11	1.6	0.08	5.1	0.27	1.6	0.08	1.3	0.07	3.9	0.20	1.2	0.06	1.0	0.05	1.3	0.07	0.4	0.02	0.3	0.02			
300	6.3	1.6	1.1	6.6	0.21	2.1	0.07	1.7	0.05	5.3	0.17	1.7	0.05	1.3	0.04	4.0	0.13	1.3	0.04	1.0	0.03	1.3	0.04	0.4	0.01	0.3	0.01			
100	2.1	0.5	0.4	7.1	0.08	2.3	0.02	2.0	0.02	5.7	0.06	1.8	0.02	1.6	0.02	4.3	0.05	1.4	0.02	1.2	0.01	1.4	0.02	0.5	0.01	0.4	0.01			
50	1.1	0.3	0.2	7.4	0.04	2.5	0.01	2.1	0.01	5.9	0.03	2.0	0.01	1.7	0.01	4.4	0.02	1.5	0.01	1.3	0.01	1.5	0.01	0.5	0.01	0.2	0.01			

SJ 25					LOAD																									
					25 kN						20 kN						15 kN						10 kN							
$n_1$ [rpm]	LINEAR SPEED $v$ [mm/s]				RATIO						RATIO						RATIO						RATIO							
	RV1	RN1	RL1	RV1	RN1	RL1	RV1	RN1	RL1	RV1	RN1	RL1	RV1	RN1	RL1	RV1	RN1	RL1	RV1	RN1	RL1	RV1	RN1	RL1	RV1	RN1	RL1	RV1	RN1	RL1
1500	25	8.3	6.3	11.7	1.83	4.8	0.76	3.9	0.61	9.3	1.47	3.9	0.60	3.1	0.49	7.0	1.10	2.9	0.45	2.3	0.37	4.6	0.74	1.9	0.30	1.6	0.25			
1000	16.7	5.6	4.2	12.2	1.28	5.0	0.53	4.1	0.43	9.8	1.03	4.0	0.42	3.3	0.34	7.3	0.77	3.0	0.32	2.5	0.26	4.8	0.52	2.0	0.21	1.6	0.18			
750	12.5	4.2	3.1	12.7	1.00	5.2	0.41	4.2	0.33	10.2	0.80	4.2	0.33	3.4	0.27	7.6	0.60	3.1	0.24	2.5	0.20	5.0	0.40	2.1	0.16	1.7	0.14			
500	8.3	2.8	2.1	13.5	0.71	5.5	0.29	4.5	0.24	10.8	0.56	4.4	0.23	3.6	0.19	8.1	0.42	3.3	0.17	2.7	0.14	5.4	0.28	2.2	0.12	1.8	0.10			
300	5	1.7	1.3	14.1	0.44	5.8	0.18	4.8	0.15	11.3	0.35	4.6	0.15	3.9	0.12	8.5	0.27	3.5	0.11	2.9	0.09	5.6	0.09	2.4	0.08	2.0	0.06			
100	1.7	0.6	0.4	15.1	0.16	6.5	0.07	5.5	0.06	12.1	0.13	5.2	0.05	4.4	0.05	9.0	0.09	3.9	0.04	3.3	0.03	6.0	0.06	2.6	0.03	2.2	0.03			
50	0.8	0.3	0.2	15.8	0.08	6.9	0.04	6.0	0.03	12.6	0.07	5.5	0.03	4.8	0.02	9.5	0.05	4.1	0.02	3.6	0.02	3.2	0.04	2.8	0.02	2.4	0.01			

SJ 50					LOAD																									
					50 kN						35 kN						25 kN						10 kN							
$n_1$ [rpm]	LINEAR SPEED $v$ [mm/s]				RATIO						RATIO						RATIO						RATIO							
	RV1	RN1	RL1	RV1	RN1	RL1	RV1	RN1	RL1	RV1	RN1	RL1	RV1	RN1	RL1	RV1	RN1	RL1	RV1	RN1	RL1	RV1	RN1	RL1	RV1	RN1	RL1	RV1	RN1	RL1
1500	25	12.5	6.3	25.0	3.92	14.4	2.26	8.5	1.34	17.5	2.74	10.0	1.58	6.0	0.94	12.5	1.96	7.2	1.13	4.3	0.67	5.0	0.78	2.9	0.45	1.7	0.27			
1000	16.7	8.3	4.2	26.5	2.78	13.3	1.60	9.1	0.96	18.6	1.94	10.7	1.12	6.4	0.67	13.3	1.39	7.6	0.80	4.6	0.48	5.3	0.56	3.1	0.32	1.8	0.19			
750	12.5	6.3	3.1	27.4	2.15	16.0	1.25	9.5	0.74	19.2	1.51	11.1	0.87	6.6	0.52	13.7	1.08	7.9	0.62	4.7	0.37	5.5	0.43	3.2	0.25	1.9	0.15			
500	8.3	4.2	2.1	28.8	1.51	16.4	0.86	10.0	0.52	20.2	1.06	11.5	0.60	7.0	0.37	14.4	0.75	8.2	0.43	5.0	0.26	5.8	0.30	3.3	0.17	2.0	0.11			
300	5	2.5	1.3	30.5	0.96	17.4	0.55	10.8	0.34	21.3	0.67	12.2	0.38	7.6	0.24	15.2	0.48	8.7	0.27	5.4	0.17	6.1	0.19	3.5	0.11	2.1	0.07			
100	1.7	0.8	0.4	33.0	0.35	19.3	0.20	12.5	0.13	23.1	0.24	13.5	0.14	8.8	0.09	16.5	0.17	9.7	0.10	6.3	0.07	6.6	0.07	3.9	0.04	2.5	0.03			
50	0.8	0.4	0.2	35.0	0.18	21.0	0.11	13.6	0.07	24.3	0.13	14.5	0.08	9.5	0.05	17.4	0.09	10.3	0.05	6.8	0.04	7.0	0.04	4.1	0.02	2.7	0.01			

# Screw jacks SJ Series - 1-start acme screw

Following tables show the screw jack LINEAR SPEED  $v$  [mm/s] and relative TORQUE  $T_1$  [Nm] and POWER  $P_1$  [kW] on input shaft, with reference to the INPUT SPEED  $n_1$  [rpm], the RATIO (RV, RN, RL) and the LOAD [kN] applied on the screw jack.

Intermediate values for linear speed  $v$ , torque  $T_1$  and power  $P_1$  at different input speed can be calculated by linear interpolation of the figures stated in the table.

The figures in the tables refer to work with max. duty cycle of 30 % over 10 min time period or 20 % over 1 hour time period at 25°C environment temperature.

**ATTENTION!** The figures in the **red shaded area** indicate operational restrictions due to thermal limits. When the selection is made within such area, the duty cycle must be reduced or the greater size screw jack must be selected, in order to allow effective heat dissipation. For a better evaluation, please contact SERVOMECH Engineering Dpt.

SJ 100				LOAD																							
				100 kN				80 kN				60 kN				40 kN											
				RATIO		RATIO		RATIO		RATIO		RATIO		RATIO		RATIO		RATIO									
$n_1$ [rpm]	LINEAR SPEED $v$ [mm/s]			RV1	RN1	RL1	RV1	RN1	RL1	RV1	RN1	RL1	RV1	RN1	RL1	RV1	RN1	RL1	RV1	RN1	RL1						
	RV1	RN1	RL1	$T_1$ Nm	$P_1$ kW	$T_1$ Nm	$P_1$ kW	$T_1$ Nm	$P_1$ kW	$T_1$ Nm	$P_1$ kW	$T_1$ Nm	$P_1$ kW	$T_1$ Nm	$P_1$ kW	$T_1$ Nm	$P_1$ kW	$T_1$ Nm	$P_1$ kW	$T_1$ Nm	$P_1$ kW						
1 500	32.0	16.0	8.0										16.3	2.56	37.6	5.91	21.8	3.43	12.2	1.92	25.1	3.94	14.6	2.29	8.2	1.28	
1 000	21.4	10.7	5.3			39.1	4.10	25.0	2.62	53.4	5.59	30.2	3.16	17.0	1.78	40.0	4.19	22.6	2.37	12.7	1.33	26.7	2.80	15.1	1.58	8.5	0.89
750	16.1	8.0	4.0	68.4	5.37	42.2	3.31	26.3	2.06	54.7	4.22	32.6	2.56	17.7	1.39	41.0	3.17	24.4	1.92	13.3	1.04	27.3	2.11	16.3	1.28	8.9	0.70
500	10.7	5.3	2.7	73.2	3.83	44.5	2.34	27.5	1.44	58.2	3.05	34.0	1.78	18.5	0.97	43.7	2.29	25.5	1.33	13.9	0.73	29.1	1.52	17.0	0.89	9.3	0.48
300	6.4	3.2	1.6	82.4	2.59	47.6	1.50	30.6	0.96	63.7	2.00	35.1	1.10	22.3	0.70	47.7	1.50	26.3	0.83	16.8	0.53	31.8	1.00	17.5	0.55	11.2	0.35
100	2.1	1.1	0.5	91.5	0.96	55.5	0.58	35.6	0.37	66.2	0.69	37.6	0.39	24.0	0.25	49.7	0.52	28.2	0.30	18.0	0.19	33.1	0.35	18.8	0.20	12.0	0.13
50	1.1	0.5	0.3	98.9	0.52	59.5	0.31	39.9	0.21	69.0	0.36	40.7	0.21	25.5	0.13	51.7	0.27	30.6	0.16	19.1	0.10	34.5	0.18	20.4	0.11	12.7	0.07

SJ 150				LOAD																							
				150 kN				120 kN				80 kN				50 kN											
				RATIO		RATIO		RATIO		RATIO		RATIO		RATIO		RATIO		RATIO									
$n_1$ [rpm]	LINEAR SPEED $v$ [mm/s]			RV1	RN1	RL1	RV1	RN1	RL1	RV1	RN1	RL1	RV1	RN1	RL1	RV1	RN1	RL1	RV1	RN1	RL1	RV1	RN1	RL1	RV1	RN1	RL1
	RV1	RN1	RL1	$T_1$ Nm	$P_1$ kW	$T_1$ Nm	$P_1$ kW	$T_1$ Nm	$P_1$ kW	$T_1$ Nm	$P_1$ kW	$T_1$ Nm	$P_1$ kW	$T_1$ Nm	$P_1$ kW	$T_1$ Nm	$P_1$ kW	$T_1$ Nm	$P_1$ kW	$T_1$ Nm	$P_1$ kW	$T_1$ Nm	$P_1$ kW	$T_1$ Nm	$P_1$ kW		
1 500	37.5	12.5	9.4																								
1 000	25	8.3	6.3			46.9	4.91	38.2	4.00			33.7	5.29	27.6	4.34			22.4	3.52	18.4	2.89	32.0	5.02	14.0	2.20	11.5	1.81
750	18.8	6.3	4.7			49.3	3.87	39.0	3.06			37.5	3.93	30.5	3.20	55.3	5.79	25.0	2.62	20.4	2.13	34.6	3.62	15.6	1.64	12.7	1.33
500	12.5	4.2	3.1	116	6.06	51.1	2.68	41.4	2.17	86.0	6.75	39.4	3.09	31.2	2.45	57.3	4.50	26.3	2.06	20.8	1.63	35.8	2.81	16.4	1.29	13.0	1.02
300	7.5	2.5	1.9	128	4.01	55.6	2.75	46.8	1.47	102	3.21	44.5	1.40	33.1	1.73	61.7	3.23	27.3	1.43	22.1	1.16	38.6	2.02	17.0	0.89	13.8	0.72
100	2.5	0.8	0.6	140	1.46	64.4	0.67	54.5	0.57	112	1.17	51.6	0.54	43.6	0.46	74.4	0.78	34.4	0.36	29.1	0.30	46.5	0.49	21.5	0.22	18.2	0.19
50	1.3	0.4	0.3	150	0.78	72.6	0.38	61.4	0.32	120	0.63	58.1	0.30	49.1	0.26	79.9	0.42	38.7	0.20	32.7	0.17	49.9	0.26	24.2	0.13	20.5	0.11

SJ 200				LOAD															
				200 kN				150 kN				100 kN				50 kN			
				RATIO		RATIO		RATIO		RATIO		RATIO		RATIO		RATIO			
$n_1$ [rpm]	LINEAR SPEED $v$ [mm/s]			RV1	RL1	RV1	RL1	RV1	RL1	RV1	RL1	RV1	RL1	RV1	RL1				
	RV1	RL1	$T_1$ Nm	$P_1$ kW	$T_1$ Nm	$P_1$ kW	$T_1$ Nm	$P_1$ kW	$T_1$ Nm	$P_1$ kW	$T_1$ Nm	$P_1$ kW	$T_1$ Nm	$P_1$ kW	$T_1$ Nm	$P_1$ kW			
1 500	42.9	10.7																	
1 000	28.6	7.1			60.1	6.29			45.1	4.72	81.2	8.50	30.0	3.15	40.6	4.25	15.0	1.57	
750	21.4	5.4			64.5	5.07	129	10.1	48.4	3.80	86.0	6.76	32.26	2.53	43.0	3.38	16.1	1.27	
500	14.3	3.6	185	9.68	67.6	3.54	139	7.26	50.7	2.5	92.4	4.84	33.8	1.77	46.2	2.42	16.9	0.88	
300	8.6	2.1	201	6.32	75.8	2.38	151	4.74	56.8	1.79	101	3.16	37.9	1.19	50.3	1.58	18.9	0.60	
100	2.9	0.7	228	2.39	86.8	0.91	171	1.79	65.1	0.68	114	1.20	43.4	0.45	57.1	0.60	21.7	0.23	
50	1.4	0.4	252	1.32	98.9	0.52	189	0.99	74.2	0.39	126	0.66	49.4	0.26	62.9	0.33	24.7	0.13	

SJ 250				LOAD															
				250 kN				200 kN				150 kN				100 kN			
				RATIO		RATIO		RATIO		RATIO		RATIO		RATIO		RATIO			
$n_1$ [rpm]	LINEAR SPEED $v$ [mm/s]			RV1	RL1	RV1	RL1	RV1	RL1	RV1	RL1	RV1	RL1	RV1	RL1				
	RV1	RL1	$T_1$ Nm	$P_1$ kW	$T_1$ Nm	$P_1$ kW	$T_1$ Nm	$P_1$ kW	$T_1$ Nm	$P_1$ kW	$T_1$ Nm	$P_1$ kW	$T_1$ Nm	$P_1$ kW	$T_1$ Nm	$P_1$ kW			
1 500	42.9	10.7																	
1 000	28.6	7.1																	
750	21.4	5.4			87.1	6.84			63.8	6.68			47.9	5.01	87.1	9.12	31.9	3.34	
500	14.3	3.6			92.9	4.87	195	10.2	74.4	3.89	146	7.65	55.8	2.92	97.3	5.10	37.2	1.95	
300	8.6	2.1	264	8.29	103	3.22	211	6.63	82.1	2.58	158	4.97	61.6	1.93	106	3.31	41.1	1.29	
100	2.9	0.7	313	3.28	119	1.24	251	2.62	95.1	1.00	188	1.97	71.3	0.75	125	1.31	47.5	0.50	
50	1.4	0.4	339	1.77	137	0.72	271	1.42	109	0.57	203	1.06	82.0	0.43	135	0.71	54.7	0.29	

## Screw jacks SJ Series - 1-start acme screw

Following tables show the screw jack LINEAR SPEED  $v$  [mm/s] and relative TORQUE  $T_1$  [Nm] and POWER  $P_1$  [kW] on input shaft, with reference to the INPUT SPEED  $n_1$  [rpm], the RATIO (RV, RN, RL) and the LOAD [kN] applied on the screw jack.

Intermediate values for linear speed  $v$ , torque  $T_1$  and power  $P_1$  at different input speed can be calculated by linear interpolation of the figures stated in the table.

The figures in the tables refer to work with max. duty cycle of 30 % over 10 min time period or 20 % over 1 hour time period at 25°C environment temperature.

**ATTENTION!** The figures in the **red shaded area** indicate operational restrictions due to thermal limits. When the selection is made within such area, the duty cycle must be reduced or the greater size screw jack must be selected, in order to allow effective heat dissipation. For a better evaluation, please contact SERVOMECH Engineering Dpt.

SJ 300			LOAD															
			300 kN				250 kN				200 kN				100 kN			
			RATIO		RATIO		RATIO		RATIO		RATIO		RATIO		RATIO			
$n_1$ [rpm]	LINEAR SPEED $v$ [mm/s]		RV1	RL1	RV1	RL1	RV1	RL1	RV1	RL1	RV1	RL1	RV1	RL1	RV1	RL1		
	RV1	RL1	$T_1$ Nm	$P_1$ kW	$T_1$ Nm	$P_1$ kW	$T_1$ Nm	$P_1$ kW	$T_1$ Nm	$P_1$ kW	$T_1$ Nm	$P_1$ kW	$T_1$ Nm	$P_1$ kW	$T_1$ Nm	$P_1$ kW		
1 500	31.0	10			86.4	13.6			72.0	11.3	130	20.5	57.6	9.05	65.1	10.2	28.8	4.52
1 000	20.7	6.7			97.0	10.2	176	18.4	80.8	8.46	141	14.8	64.7	6.77	70.4	7.37	32.3	3.39
750	15.5	5	223	17.5	105	8.24	186	14.6	87.4	6.87	149	11.7	69.9	5.49	74.4	5.84	35.0	2.75
500	10.3	3.3	242	12.7	113	5.93	202	10.6	94.3	4.94	161	8.45	75.5	3.95	80.7	4.23	37.7	1.98
300	6.2	2	270	8.48	121	3.80	225	7.06	101	3.16	180	5.65	80.6	2.53	90.0	2.83	40.3	1.27
100	2.1	0.7	307	3.21	148	1.55	256	2.68	123	1.29	205	2.14	98.6	1.03	102	1.07	49.3	0.52
50	1.0	0.3	341	1.78	167	0.87	284	1.49	139	0.73	227	1.19	111	0.58	114	0.59	55.5	0.29

SJ 350			LOAD															
			350 kN				300 kN				200 kN				100 kN			
			RATIO		RATIO		RATIO		RATIO		RATIO		RATIO		RATIO			
$n_1$ [rpm]	LINEAR SPEED $v$ [mm/s]		RV1	RL1	RV1	RL1	RV1	RL1	RV1	RL1	RV1	RL1	RV1	RL1	RV1	RL1		
	RV1	RL1	$T_1$ Nm	$P_1$ kW	$T_1$ Nm	$P_1$ kW	$T_1$ Nm	$P_1$ kW	$T_1$ Nm	$P_1$ kW	$T_1$ Nm	$P_1$ kW	$T_1$ Nm	$P_1$ kW	$T_1$ Nm	$P_1$ kW		
1 500	31.0	10							92.2	14.5			61.4	9.65	66.5	10.5	30.7	4.83
1 000	20.7	6.7			119	12.5			102	10.7	149	15.6	68.0	7.12	74.6	7.81	34.0	3.56
750	15.5	5			129	10.1	235	18.5	111	8.68	157	12.3	73.7	5.79	78.3	6.15	36.9	2.89
500	10.3	3.3	299	15.6	142	7.4	256	13.4	122	6.37	171	8.94	81.1	4.25	85.3	4.47	40.5	2.12
300	6.2	2	337	10.6	151	4.75	289	9.07	130	4.07	192	6.04	86.4	2.71	96.2	3.02	43.2	1.36
100	2.1	0.7	388	4.06	186	1.95	332	3.48	159	1.67	222	2.32	106	1.11	111	1.16	53.2	0.56
50	1.0	0.3	425	2.22	208	1.09	364	1.91	178	0.93	243	1.27	119	0.62	121	0.64	59.4	0.31

SJ 400			LOAD															
			400 kN				300 kN				200 kN				100 kN			
			RATIO		RATIO		RATIO		RATIO		RATIO		RATIO		RATIO			
$n_1$ [rpm]	LINEAR SPEED $v$ [mm/s]		RV1	RL1	RV1	RL1	RV1	RL1	RV1	RL1	RV1	RL1	RV1	RL1	RV1	RL1		
	RV1	RL1	$T_1$ Nm	$P_1$ kW	$T_1$ Nm	$P_1$ kW	$T_1$ Nm	$P_1$ kW	$T_1$ Nm	$P_1$ kW	$T_1$ Nm	$P_1$ kW	$T_1$ Nm	$P_1$ kW	$T_1$ Nm	$P_1$ kW		
1 500	32.1	10.3			125	19.7	206	32.4	94.1	14.8	137	21.6	62.7	9.86	68.7	10.8	31.4	4.93
1 000	21.4	6.9	303	31.7	141	14.7	227	12.8	106	11.1	152	15.9	70.4	7.37	75.8	7.93	35.2	3.69
750	16.1	5.2	323	25.4	149	11.7	242	19.0	112	8.79	161	12.7	74.6	5.86	80.7	6.34	37.3	2.93
500	10.7	3.4	344	18.3	166	8.71	258	13.5	125	6.53	172	9.01	83.2	4.35	86.1	4.51	41.6	2.18
300	6.4	2.1	393	12.4	178	5.60	295	9.27	134	4.20	197	6.18	89.1	2.80	98.4	3.09	44.5	1.40
100	2.1	0.7	458	4.79	219	2.29	343	3.60	164	1.72	229	2.40	109	1.14	114	1.20	54.7	0.57
50	1.1	0.3	510	2.67	250	1.31	384	2.00	187	0.98	255	1.34	125	0.65	128	0.67	62.4	0.33

SJ 600			LOAD															
			600 kN				500 kN				400 kN				200 kN			
			RATIO		RATIO		RATIO		RATIO		RATIO		RATIO		RATIO			
$n_1$ [rpm]	LINEAR SPEED $v$ [mm/s]		RV1	RL1	RV1	RL1	RV1	RL1	RV1	RL1	RV1	RL1	RV1	RL1	RV1	RL1		
	RV1	RL1	$T_1$ Nm	$P_1$ kW	$T_1$ Nm	$P_1$ kW	$T_1$ Nm	$P_1$ kW	$T_1$ Nm	$P_1$ kW	$T_1$ Nm	$P_1$ kW	$T_1$ Nm	$P_1$ kW	$T_1$ Nm	$P_1$ kW		
1 500	37.5	12.1			220	34.5			183	28.8			146	23.0	155	24.4	73.2	11.5
1 000	25	8.0			241	25.1			200	21.0	349	36.5	160	16.8	174	18.3	80.0	8.38
750	18.8	6.0			263	20.7	471	37.0	219	17.2	377	29.6	175	13.8	188	14.8	87.7	6.88
500	12.5	4.0	608	31.8	292	15.3	507	26.5	243	12.8	405	21.2	195	10.2	203	10.6	97.4	5.50
300	7.5	2.4	671	21.1	316	9.94	559	17.6	264	8.28	447	14.1	211	6.62	224	7.03	105	3.31
100	2.5	0.8	813	8.51	397	4.15	677	7.09	330	3.46	542	5.67	264	2.77	271	2.84	132	1.8
50	1.3	0.4	893	4.68	437	2.29	744	3.90	364	1.91	595	3.12	291	1.52	298	1.56	146	0.76



## Screw jacks SJ Series - 1-start acme screw

Following tables show the screw jack LINEAR SPEED  $v$  [mm/s] and relative TORQUE  $T_1$  [Nm] and POWER  $P_1$  [kW] on input shaft, with reference to the INPUT SPEED  $n_1$  [rpm], the RATIO (RV, RN, RL) and the LOAD [kN] applied on the screw jack.

Intermediate values for linear speed  $v$ , torque  $T_1$  and power  $P_1$  at different input speed can be calculated by linear interpolation of the figures stated in the table.

The figures in the tables refer to work with max. duty cycle of 30 % over 10 min time period or 20 % over 1 hour time period at 25°C environment temperature.

**ATTENTION!** The figures in the **red shaded area** indicate operational restrictions due to thermal limits. When the selection is made within such area, the duty cycle must be reduced or the greater size screw jack must be selected, in order to allow effective heat dissipation. For a better evaluation, please contact SERVOMECH Engineering Dpt.

SJ 800			LOAD															
			800 kN				600 kN				400 kN				200 kN			
			RATIO		RATIO		RATIO		RATIO		RATIO		RATIO		RATIO			
$n_1$ [rpm]	LINEAR SPEED $v$ [mm/s]		RV1	RL1	$T_1$ Nm	$P_1$ kW	$T_1$ Nm	$P_1$ kW	$T_1$ Nm	$P_1$ kW	$T_1$ Nm	$P_1$ kW	$T_1$ Nm	$P_1$ kW	$T_1$ Nm	$P_1$ kW	$T_1$ Nm	$P_1$ kW
	1 500	30	9.7			263	41.4			197	31.0	280	44.0	132	20.8	140	22.0	65.8
1 000	20	6.5			284	29.8	472	49.4	213	22.3	314	33.0	142	14.9	157	16.5	71.1	7.44
750	15	4.9			309	24.3	501	39.4	232	18.2	334	26.2	155	12.2	167	13.1	77.3	6.07
500	10	3.2	722	37.8	349	18.3	541	28.4	262	13.7	361	18.9	175	9.15	180	9.45	87.4	4.57
300	6	1.9	827	26.0	379	11.9	620	19.5	284	8.94	414	13.0	190	5.95	207	6.50	94.8	2.98
100	2	0.6	978	10.2	480	5.02	733	7.68	360	3.77	489	5.12	240	2.51	244	2.56	120	1.26
50	1	0.3	1 076	5.63	527	2.76	807	4.23	395	2.07	538	2.82	263	1.38	269	1.41	132	0.69

SJ 1000			LOAD															
			1000 kN				800 kN				600 kN				400 kN			
			RATIO		RATIO		RATIO		RATIO		RATIO		RATIO		RATIO			
$n_1$ [rpm]	LINEAR SPEED $v$ [mm/s]		RV1	RL1	$T_1$ Nm	$P_1$ kW	$T_1$ Nm	$P_1$ kW	$T_1$ Nm	$P_1$ kW	$T_1$ Nm	$P_1$ kW	$T_1$ Nm	$P_1$ kW	$T_1$ Nm	$P_1$ kW	$T_1$ Nm	$P_1$ kW
	1 500	34.3	11.1							294	46.2			220	34.7	312	49.0	147
1 000	22.9	7.4			402	42.1			321	33.7	520	54.5	241	25.2	347	36.3	161	16.8
750	17.1	5.6			437	34.3	737	58.0	350	27.5	553	43.5	262	20.6	369	29.0	175	13.7
500	11.4	3.7	1 008	52.8	486	25.4	806	42.2	388	20.3	605	31.7	291	15.2	403	21.1	194	10.1
300	6.9	2.2	1 148	36.1	541	17.0	918	28.9	433	13.6	689	21.6	325	10.2	459	14.4	217	6.80
100	2.3	0.7	1 397	14.6	679	7.11	1 117	11.7	543	5.69	838	8.77	408	4.27	559	5.85	272	2.85
50	1.1	0.4	1 544	8.08	760	3.98	1 235	6.47	608	3.18	926	4.85	456	2.39	618	3.23	304	1.59

### Total efficiency of screw jack with 1-start acme screw

$\eta$	SJ 5				SJ 10			SJ 25			SJ 50			SJ 100			SJ 150		
	RH1	RV1	RN1	RL1	RV1	RN1	RL1	RV1	RN1	RL1	RV1	RN1	RL1	RV1	RN1	RL1	RV1	RN1	RL1
$n_1$ [rpm]																			
1 500	0.35	0.34	0.29	0.25	0.36	0.28	0.25	0.34	0.27	0.25	0.32	0.28	0.23	0.33	0.29	0.24	0.37	0.28	0.26
1 000	0.33	0.32	0.28	0.24	0.34	0.27	0.24	0.32	0.26	0.24	0.30	0.26	0.22	0.31	0.27	0.23	0.35	0.25	0.23
750	0.32	0.31	0.27	0.23	0.33	0.26	0.23	0.31	0.25	0.23	0.29	0.25	0.21	0.30	0.26	0.22	0.33	0.24	0.23
500	0.30	0.29	0.26	0.21	0.31	0.25	0.21	0.29	0.24	0.22	0.28	0.24	0.20	0.29	0.25	0.21	0.31	0.23	0.22
300	0.29	0.28	0.25	0.20	0.30	0.24	0.20	0.28	0.23	0.20	0.26	0.23	0.18	0.27	0.24	0.19	0.28	0.21	0.19
100	0.27	0.26	0.23	0.17	0.28	0.22	0.17	0.26	0.20	0.18	0.24	0.21	0.16	0.25	0.22	0.17	0.26	0.19	0.16
50	0.26	0.25	0.21	0.16	0.27	0.20	0.16	0.25	0.19	0.17	0.23	0.19	0.15	0.24	0.20	0.16	0.24	0.16	0.15
AT START	0.22	0.22	0.19	0.15	0.23	0.18	0.14	0.20	0.16	0.13	0.18	0.15	0.11	0.20	0.17	0.13	0.21	0.14	0.13

$\eta$	SJ 200		SJ 250		SJ 300		SJ 350		SJ 400		SJ 600		SJ 800		SJ 1000	
	RV1	RL1	RV1	RL1	RV1	RL1	RV1	RL1	RV1	RL1	RV1	RL1	RV1	RL1	RV1	RL1
$n_1$ [rpm]																
1 500	0.36	0.26	0.35	0.24	0.30	0.22	0.30	0.21	0.30	0.21	0.31	0.21	0.27	0.19	0.28	0.19
1 000	0.34	0.23	0.31	0.21	0.28	0.20	0.26	0.19	0.27	0.19	0.27	0.19	0.24	0.17	0.25	0.18
750	0.32	0.21	0.30	0.20	0.27	0.18	0.25	0.17	0.25	0.18	0.25	0.18	0.23	0.16	0.24	0.16
500	0.30	0.20	0.28	0.18	0.24	0.17	0.23	0.16	0.24	0.16	0.24	0.16	0.21	0.14	0.22	0.15
300	0.27	0.18	0.26	0.17	0.22	0.16	0.21	0.15	0.21	0.15	0.21	0.15	0.18	0.13	0.19	0.13
100	0.24	0.16	0.22	0.14	0.19	0.13	0.18	0.12	0.18	0.12	0.18	0.12	0.16	0.10	0.16	0.10
50	0.22	0.14	0.20	0.12	0.17	0.11	0.16	0.11	0.16	0.11	0.16	0.11	0.14	0.09	0.14	0.09
AT START	0.19	0.12	0.17	0.11	0.14	0.09	0.13	0.09	0.13	0.08	0.13	0.08	0.11	0.07	0.11	0.07

## Screw jacks SJ Series

### Screw jacks SJ Series with 2-starts acme screw TECHNICAL SPECIFICATIONS

SCREW JACK SIZE		SJ 5	SJ 10	SJ 25	SJ 50	SJ 100	SJ 150	SJ 200	
Load capacity [kN], (push - pull)		5	10	25	50	100	150	200	
2-starts acme screw		Tr 18x8 (P4)	Tr 22x10 (P5)	Tr 30x12 (P6)	Tr 40x14 (P7)	Tr 55x18 (P9)	Tr 60x24 (P12)	Tr 70x24 (P12)	
Worm gear centre distance [mm]		25	30	50	63	63	80	90	
Available ratio	RH	1 : 4 (5 : 20)	—	—	—	—	—	—	
	RV	1 : 6.25 (4 : 25)	1 : 4 (4 : 16)	1 : 6 (4 : 24)	1 : 7 (4 : 28)	1 : 7 (4 : 28)	1 : 8 (4 : 32)	1 : 7 (4 : 28)	
	RN	1 : 12.5 (2 : 25)	1 : 16 (2 : 32)	1 : 18 (2 : 36)	1 : 14 (2 : 28)	1 : 14 (2 : 28)	1 : 24	—	
	RL	1 : 25	1 : 24	1 : 24	1 : 28	1 : 28	1 : 32	1 : 28	
Stroke [mm] for 1 input shaft revolution	Ratio	RH1	2	—	—	—	—	—	
		RV1	1.28	2.5	2	2	2.57	3	3.43
		RN1	0.64	0.625	0.67	1	1.29	1	—
		RL1	0.32	0.42	0.5	0.5	0.64	0.75	0.86
Starting efficiency	Ratio	RH1	0.32	—	—	—	—	—	
		RV1	0.32	0.33	0.31	0.29	0.28	0.30	0.28
		RN1	0.28	0.26	0.23	0.24	0.23	0.21	—
		RL1	0.21	0.20	0.20	0.18	0.17	0.19	0.18
Running efficiency at 1500 rpm <sup>(1)</sup>	Ratio	RH1	0.48	—	—	—	—	—	
		RV1	0.45	0.50	0.47	0.46	0.46	0.49	0.48
		RN1	0.41	0.38	0.38	0.40	0.40	0.39	—
		RL1	0.33	0.34	0.34	0.33	0.33	0.36	0.36
Starting torque on input shaft at max. load [Nm]	Ratio	RH1	5	—	—	—	—	—	
		RV1	3.2	12.2	26.0	56	149	238	391
		RN1	1.9	3.9	11.4	33.5	90	114	—
		RL1	1.2	3.3	10.0	22.4	60	94	153
Max. permissible operating power [kW] <sup>(2)</sup>	Ratio	RH1	0.55	—	—	—	—	—	
		RV1	0.55	0.80	1.6	3.4	3.5	4	5.5
		RN1	0.28	0.40	1	2.4	2.4	3.6	—
		RL1	0.25	0.34	0.8	1.6	1.6	3.5	4.4
Reactive torque on acme screw (nut) required at max. load [Nm]		12	30	100	250	650	1 150	1 700	
Gear box material		casting in aluminium alloy EN 1706 - AC-AISi10Mg T6			casting in cast iron EN-GJL-250 (UNI EN 1561)				
Mass of screw jack without acme screw [kg]		1.5	2.3	10.4	25	35	55	75	
Mass for every 100 mm of acme screw [kg]		0.16	0.23	0.45	0.8	1.6	1.8	2.5	

<sup>(1)</sup> - efficiency figures at different input speed on page 67

<sup>(2)</sup> - THERMAL limit, referred to work with max. duty cycle 30 % over 10 min time period (20 % over 1 hour time period) at 25°C environment temperature

# Screw jacks SJ Series

## Screw jacks SJ Series with 2-starts acme screw TECHNICAL SPECIFICATIONS

SJ 250	SJ 300	SJ 350	SJ 400	SJ 600	SJ 800	SJ 1000	SCREW JACK SIZE	
250	300	350	400	600	800	1000	Load capacity [kN], (push - pull)	
Tr 80x24 (P12)	Tr 90x24 (P12)	Tr 100x24 (P12)	Tr 100x24 (P12)	Tr 120x28 (P14)	Tr 140x28 (P14)	Tr 160x32 (P16)	2-starts acme screw	
90	110	110	140	140	200	200	Worm gear centre distance [mm]	
—	—	—	—	—	—	—	RH	
1 : 7 (4 : 28)	3 : 29	3 : 29	3 : 28	3 : 28	3 : 35	3 : 35	RV	
—	—	—	—	—	—	—	RN	
1 : 28	1 : 30	1 : 30	1 : 29	1 : 29	1 : 36	1 : 36	RL	
—	—	—	—	—	—	—	RH1	
3.43	2.48	2.48	2.57	3	2.4	2.74	RV1	
—	—	—	—	—	—	—	RN1	
0.86	0.8	0.8	0.83	0.97	0.78	0.89	RL1	
—	—	—	—	—	—	—	RH1	
0.28	0.23	0.21	0.21	0.20	0.18	0.18	RV1	
—	—	—	—	—	—	—	RN1	
0.18	0.15	0.14	0.13	0.13	0.11	0.11	RL1	
—	—	—	—	—	—	—	RH1	
0.48	0.43	0.42	0.42	0.43	0.40	0.41	RV1	
—	—	—	—	—	—	—	RN1	
0.36	0.33	0.31	0.31	0.31	0.29	0.29	RL1	
—	—	—	—	—	—	—	RH1	
527	521	650	790	1 407	1 685	2 405	RV1	
—	—	—	—	—	—	—	RN1	
206	257	320	399	711	866	1 237	RL1	
—	—	—	—	—	—	—	RH1	
5.5	11	11	21	23	30	36	RV1	
—	—	—	—	—	—	—	RN1	
4.4	9	9	17	20	26	33	RL1	
2 280	2 950	3 680	4 200	7 500	11 100	15 900	Reactive torque on acme screw (nut) required at max. load [Nm]	
casting in cast iron EN-GJL-250 (UNI EN 1561)			casting in steel Fe G 60 (UNI 4010)				Gear box material	
75	120	120	260	260	800	800	Mass of screw jack without acme screw [kg]	
3.4	4.4	5.5	5.5	7.9	10.9	14.2	Mass for every 100 mm of acme screw [kg]	

(<sup>1</sup>) - efficiency figures at different input speed on page 67

(<sup>2</sup>) - THERMAL limit, referred to work with max. duty cycle 30 % over 10 min time period (20 % over 1 hour time period)  
at 25°C environment temperature

# Screw jacks SJ Series - 2-starts acme screw

Following tables show the screw jack LINEAR SPEED  $v$  [mm/s] and relative TORQUE  $T_1$  [Nm] and POWER  $P_1$  [kW] on input shaft, with reference to the INPUT SPEED  $n_1$  [rpm], the RATIO (RV, RN, RL) and the LOAD [kN] applied on the screw jack.

Intermediate values for linear speed  $v$ , torque  $T_1$  and power  $P_1$  at different input speed can be calculated by linear interpolation of the figures stated in the table.

The figures in the tables refer to work with max. duty cycle of 30 % over 10 min time period or 20 % over 1 hour time period at 25°C environment temperature.

**ATTENTION!** The figures in the **red shaded area** indicate operational restrictions due to thermal limits. When the selection is made within such area, the duty cycle must be reduced or the greater size screw jack must be selected, in order to allow effective heat dissipation. For a better evaluation, please contact SERVOMECH Engineering Dpt.

SJ 5					LOAD																							
					5 kN								3 kN								1 kN							
$n_1$ [rpm]	LINEAR SPEED $v$ [mm/s]				RATIO								RATIO								RATIO							
	RH2	RV2	RN2	RL2	RH2		RV2		RN2		RL2		RH2		RV2		RN2		RL2		RH2		RV2		RN2		RL2	
					$T_1$ Nm	$P_1$ kW	$T_1$ Nm	$P_1$ kW	$T_1$ Nm	$P_1$ kW	$T_1$ Nm	$P_1$ kW	$T_1$ Nm	$P_1$ kW	$T_1$ Nm	$P_1$ kW	$T_1$ Nm	$P_1$ kW	$T_1$ Nm	$P_1$ kW	$T_1$ Nm	$P_1$ kW	$T_1$ Nm	$P_1$ kW	$T_1$ Nm	$P_1$ kW	$T_1$ Nm	$P_1$ kW
1500	50	32	16	8	3.4	0.53	2.3	0.35	1.3	0.19	0.8	0.12	2.0	0.32	1.4	0.21	0.8	0.12	0.5	0.07	0.7	0.11	0.5	0.07	0.3	0.04	0.2	0.02
1000	33.3	21.3	10.7	5.3	3.5	0.37	2.4	0.25	1.4	0.14	0.9	0.09	2.1	0.22	1.4	0.15	0.8	0.09	0.5	0.05	0.7	0.07	0.5	0.05	0.3	0.03	0.2	0.02
750	25	16	8	4	3.7	0.29	2.5	0.19	1.4	0.11	0.9	0.07	2.2	0.17	1.5	0.12	0.9	0.07	0.5	0.04	0.8	0.06	0.5	0.04	0.3	0.02	0.2	0.01
500	16.7	10.7	5.3	2.7	3.9	0.20	2.6	0.13	1.5	0.08	0.9	0.05	2.3	0.12	1.5	0.08	0.9	0.05	0.6	0.03	0.8	0.04	0.5	0.03	0.3	0.02	0.2	0.01
300	10	6.4	3.2	1.6	4.0	0.13	2.7	0.08	1.6	0.05	1.0	0.03	2.4	0.08	1.6	0.05	0.9	0.03	0.6	0.02	0.8	0.03	0.6	0.02	0.3	0.01	0.2	0.01
100	3.3	2.1	1.1	0.5	4.5	0.05	2.9	0.03	1.7	0.02	1.1	0.01	2.7	0.03	1.7	0.02	1.0	0.01	0.7	0.01	0.9	0.01	0.6	0.01	0.4	0.01	0.3	0.01
50	1.7	1.1	0.5	0.3	4.6	0.02	3.0	0.02	1.8	0.01	1.2	0.01	2.8	0.01	1.8	0.01	1.1	0.01	0.7	0.01	0.9	0.01	0.6	0.01	0.4	0.01	0.3	0.01

SJ 10					LOAD																							
					10 kN						8 kN						6 kN						2 kN					
$n_1$ [rpm]	LINEAR SPEED $v$ [mm/s]				RATIO						RATIO						RATIO						RATIO					
	RV2	RN2	RL2	RV2	RN2	RL2	RV2	RN2	RL2	RV2	RN2	RL2	RV2	RN2	RL2	RV2	RN2	RL2	RV2	RN2	RL2	RV2	RN2	RL2	RV2	RN2	RL2	
																												$T_1$ Nm
1500	62.5	15.6	10.4	8.1	1.26	2.6	0.41	2.0	0.31	6.4	1.01	2.1	0.33	1.6	0.25	4.8	0.76	1.6	0.24	1.2	0.19	1.6	0.25	0.5	0.08	0.4	0.06	
1000	41.7	10.4	6.9	8.4	0.88	2.7	0.28	2.1	0.22	6.8	0.71	2.2	0.23	1.7	0.18	5.1	0.53	1.6	0.17	1.3	0.13	1.7	0.18	0.6	0.06	0.4	0.04	
750	31.3	7.8	5.2	8.7	0.68	2.8	0.22	2.3	0.17	7.0	0.55	2.3	0.18	1.8	0.14	5.2	0.41	1.7	0.13	1.4	0.10	1.8	0.14	0.6	0.04	0.5	0.03	
500	20.8	5.2	3.5	9.2	0.48	2.9	0.15	2.4	0.12	7.4	0.39	2.3	0.12	1.9	0.10	5.5	0.29	1.8	0.09	1.4	0.07	1.9	0.10	0.6	0.03	0.5	0.02	
300	12.5	3.1	2.1	9.8	0.31	3.1	0.10	2.5	0.08	7.8	0.24	2.5	0.08	2.0	0.06	5.9	0.18	1.9	0.06	1.5	0.05	2.0	0.06	0.6	0.02	0.5	0.02	
100	4.2	1.0	0.7	10.7	0.11	3.5	0.04	3.0	0.03	8.6	0.09	2.8	0.03	2.4	0.02	6.4	0.07	2.1	0.02	1.8	0.02	2.2	0.02	0.7	0.01	0.6	0.01	
50	2.1	0.5	0.3	10.9	0.06	3.8	0.02	3.1	0.02	8.7	0.05	3.0	0.02	2.5	0.01	6.6	0.03	2.3	0.01	1.9	0.01	2.2	0.01	0.8	0.01	0.6	0.01	

SJ 25					LOAD																							
					25 kN						20 kN						15 kN						10 kN					
$n_1$ [rpm]	LINEAR SPEED $v$ [mm/s]				RATIO						RATIO						RATIO						RATIO					
	RV2	RN2	RL2	RV2	RN2	RL2	RV2	RN2	RL2	RV2	RN2	RL2	RV2	RN2	RL2	RV2	RN2	RL2	RV2	RN2	RL2	RV2	RN2	RL2	RV2	RN2	RL2	
																												$T_1$ Nm
1500	50	16.7	12.5	17.0	2.66	7.0	1.10	5.8	0.91	13.6	2.13	5.6	0.88	4.7	0.73	10.2	1.60	4.2	0.66	3.5	0.55	6.8	1.07	2.8	0.44	2.3	0.36	
1000	33.3	11.1	8.3	17.7	1.85	7.4	0.78	6.1	0.64	14.2	1.48	6.0	0.62	4.9	0.51	10.6	1.11	4.5	0.47	3.7	0.38	7.1	0.74	3.0	0.31	2.5	0.25	
750	25	8.3	6.3	18.2	1.43	7.7	0.60	6.3	0.49	14.6	1.14	6.1	0.48	5.1	0.39	10.9	0.86	4.6	0.36	3.8	0.30	7.3	0.57	3.1	0.24	2.5	0.20	
500	16.7	5.6	4.2	19.5	1.02	8.1	0.42	6.8	0.35	15.6	0.82	6.5	0.34	5.4	0.28	11.7	0.61	4.9	0.25	4.1	0.21	7.8	0.41	3.2	0.17	2.7	0.14	
300	10	3.3	2.5	20.5	0.64	8.6	0.27	7.3	0.23	16.4	0.52	6.9	0.22	5.8	0.18	12.3	0.39	5.2	0.16	4.4	0.14	8.2	0.26	3.4	0.11	2.9	0.09	
100	3.3	1.1	0.8	22.6	0.24	9.8	0.10	8.5	0.09	18.6	0.19	7.8	0.08	6.8	0.07	13.5	0.14	5.9	0.06	5.1	0.05	9.1	0.09	3.9	0.04	3.4	0.04	
50	1.7	0.6	0.4	23.6	0.12	10.4	0.05	9.1	0.05	18.9	0.10	8.3	0.04	7.3	0.04	14.2	0.07	6.2	0.03	5.5	0.03	9.5	0.05	4.2	0.02	3.7	0.02	

SJ 50					LOAD																							
					50 kN						35 kN						25 kN						10 kN					
$n_1$ [rpm]	LINEAR SPEED $v$ [mm/s]				RATIO						RATIO						RATIO						RATIO					
	RV2	RN2	RL2	RV2	RN2	RL2	RV2	RN2	RL2	RV2	RN2	RL2	RV2	RN2	RL2	RV2	RN2	RL2	RV2	RN2	RL2	RV2	RN2	RL2	RV2	RN2	RL2	
																												$T_1$ Nm
1500	50	25	12.5	34.8	5.46	20.1	3.15	12.1	1.91	24.3	3.82	14.1	2.21	8.50	1.33	17.4	2.73	10.0	1.58	6.1	0.95	7.0	1.09	4.0	0.63	2.5	0.38	
1000	33.3	16.7	8.3	37.1	3.88	21.3	2.23	13.1	1.37	26.0	2.72	14.9	1.56	9.16	0.96	18.5	1.94	10.6	1.11	6.6	0.69	7.4	0.78	4.3	0.45	2.6	0.27	
750	25	12.5	6.3	38.2	3.00	22.6	1.77	13.5	1.06	26.7	2.10	15.8	1.24	9.45	0.74	19.1	1.50	11.3	0.89	6.7	0.53	7.7	0.60	4.5	0.35	2.7	0.21	
500	16.7	8.3	4.2	40.6	2.13	23.5	1.23	14.4	0.75	28.4	1.49	16.4	0.86	10.1	0.53	20.3	1.06	11.7	0.61	7.2	0.38	8.1	0.43	4.7	0.25	2.9	0.15	
300	10	5	2.5	43.3	1.36	24.8	0.78	15.8	0.49	30.3	0.95	17.3	0.54	11.0	0.35	21.6	0.68	12.4	0.39	7.9	0.25	8.7	0.27	5.0	0.16	3.2	0.10	
100	3.3	1.7	0.8	46.7	0.49	28.0	0.29	18.2	0.19	32.7	0.34	19.6	0.20	12.7	0.13	23.3	0.24	14.0	0.15	9.1	0.10	9.4	0.10	5.6	0.06	3.7	0.04	
50	1.7	0.8	0.4	50.3	0.26	30.4	0.16	20.5	0.11	35.2	0.18	21.3	0.11	14.3	0.08	25.1	0.13	15.2	0.08	10.2	0.05	10.1	0.05	6.1	0.03	4.1	0.02	

## Screw jacks SJ Series - 2-starts acme screw

Following tables show the screw jack LINEAR SPEED  $v$  [mm/s] and relative TORQUE  $T_1$  [Nm] and POWER  $P_1$  [kW] on input shaft, with reference to the INPUT SPEED  $n_1$  [rpm], the RATIO (RV, RN, RL) and the LOAD [kN] applied on the screw jack.

Intermediate values for linear speed  $v$ , torque  $T_1$  and power  $P_1$  at different input speed can be calculated by linear interpolation of the figures stated in the table.

The figures in the tables refer to work with max. duty cycle of 30 % over 10 min time period or 20 % over 1 hour time period at 25°C environment temperature.

**ATTENTION!** The figures in the **red shaded area** indicate operational restrictions due to thermal limits. When the selection is made within such area, the duty cycle must be reduced or the greater size screw jack must be selected, in order to allow effective heat dissipation. For a better evaluation, please contact SERVOMECH Engineering Dpt.

SJ 100				LOAD																							
				100 kN				80 kN				60 kN				40 kN											
				RATIO			RATIO			RATIO			RATIO			RATIO			RATIO								
$n_1$ [rpm]	LINEAR SPEED $v$ [mm/s]			RV2	RN2	RL2	RV2	RN2	RL2	RV2	RN2	RL2	RV2	RN2	RL2	RV2	RN2	RL2	RV2	RN2	RL2						
	RV2	RN2	RL2	$T_1$ Nm	$P_1$ kW	$T_1$ Nm	$P_1$ kW	$T_1$ Nm	$P_1$ kW	$T_1$ Nm	$P_1$ kW	$T_1$ Nm	$P_1$ kW	$T_1$ Nm	$P_1$ kW	$T_1$ Nm	$P_1$ kW	$T_1$ Nm	$P_1$ kW	$T_1$ Nm	$P_1$ kW						
1 500	64.3	32.1	16.1										25.0	3.92	53.7	8.44	30.6	4.81	18.7	2.94	35.8	5.62	20.4	3.20	12.5	1.96	
1 000	42.9	21.4	10.7			54.8	5.74	34.2	3.58	76.2	7.98	43.9	4.59	27.4	2.87	57.1	5.98	32.9	3.45	20.5	2.15	38.1	3.99	21.9	2.30	13.7	1.43
750	32.1	16.1	8.0	97.5	7.66	58.4	5.48	35.7	2.80	78.0	6.13	46.7	3.67	28.6	2.24	58.5	4.60	35.0	2.75	21.4	1.68	39.0	3.06	23.4	1.83	14.3	1.12
500	21.4	10.7	5.4	103	5.39	61.3	3.21	37.4	1.96	82.3	4.31	49.1	2.57	30.0	1.57	61.7	3.23	36.8	1.93	22.5	1.18	41.2	2.15	24.5	1.28	15.0	0.78
300	12.9	6.4	3.2	113	3.55	64.8	2.04	41.2	1.29	90.5	2.84	51.8	1.63	32.9	1.03	67.9	2.13	38.9	1.22	24.7	0.78	45.3	1.42	25.9	0.81	16.5	0.52
100	4.3	2.1	1.1	124	1.29	74.1	0.78	47.4	0.50	98.8	1.03	59.3	0.62	37.9	0.40	74.1	0.78	44.5	0.47	28.4	0.30	49.4	0.52	29.6	0.31	19.0	0.20
50	2.1	1.1	0.5	132	0.69	78.8	0.41	52.4	0.27	106	0.55	63.0	0.33	41.9	0.22	79.2	0.41	47.3	0.25	31.4	0.16	52.8	0.28	31.5	0.16	21.0	0.11

SJ 150				LOAD																							
				150 kN				120 kN				80 kN				50 kN											
				RATIO			RATIO			RATIO			RATIO			RATIO			RATIO								
$n_1$ [rpm]	LINEAR SPEED $v$ [mm/s]			RV2	RN2	RL2	RV2	RN2	RL2	RV2	RN2	RL2	RV2	RN2	RL2	RV2	RN2	RL2	RV2	RN2	RL2	RV2	RN2	RL2	RV2	RN2	RL2
	RV2	RN2	RL2	$T_1$ Nm	$P_1$ kW	$T_1$ Nm	$P_1$ kW	$T_1$ Nm	$P_1$ kW	$T_1$ Nm	$P_1$ kW	$T_1$ Nm	$P_1$ kW	$T_1$ Nm	$P_1$ kW	$T_1$ Nm	$P_1$ kW	$T_1$ Nm	$P_1$ kW	$T_1$ Nm	$P_1$ kW	$T_1$ Nm	$P_1$ kW	$T_1$ Nm	$P_1$ kW		
1 500	75	25	18.8																								
1 000	50	16.7	12.5			66.9	7.00	54.1	5.67			53.5	5.60	43.3	4.54	82.3	8.62	35.7	3.73	28.9	3.02	51.5	5.39	22.3	2.33	18.1	1.89
750	37.5	12.5	9.4			69.9	5.49	55.2	4.33	127	9.98	55.9	4.39	44.2	3.47	84.8	6.66	37.3	2.93	29.4	2.31	53.0	4.16	23.3	1.83	18.4	1.44
500	25	8.3	6.3	168	8.80	72.4	3.79	58.4	3.06	134	7.04	57.9	3.03	46.7	2.45	89.6	4.69	38.6	2.02	31.1	1.63	56.0	2.93	24.1	1.26	19.5	1.02
300	15	5	3.8	182	5.70	78.2	2.46	65.1	2.05	145	4.56	62.6	1.97	52.1	1.64	96.8	3.04	41.7	1.31	34.7	1.09	60.5	1.90	26.1	0.82	21.7	0.68
100	5	1.7	1.3	196	2.06	89.3	0.93	75.0	0.79	157	1.64	71.4	0.75	60.0	0.63	105	1.10	47.6	0.50	40.0	0.42	65.4	0.69	29.7	0.31	25.0	0.26
50	2.5	0.8	0.6	208	1.09	99.1	0.52	83.2	0.44	167	0.87	79.3	0.42	66.7	0.35	111	0.58	52.9	0.28	44.4	0.23	69.4	0.36	33.0	0.17	27.8	0.15

SJ 200				LOAD															
				200 kN				150 kN				100 kN				50 kN			
				RATIO		RATIO		RATIO		RATIO		RATIO		RATIO		RATIO		RATIO	
$n_1$ [rpm]	LINEAR SPEED $v$ [mm/s]		RV2	RL2	RV2	RL2	RV2	RL2	RV2	RL2	RV2	RL2	RV2	RL2	RV2	RL2			
	RV2	RL2	$T_1$ Nm	$P_1$ kW	$T_1$ Nm	$P_1$ kW	$T_1$ Nm	$P_1$ kW	$T_1$ Nm	$P_1$ kW	$T_1$ Nm	$P_1$ kW	$T_1$ Nm	$P_1$ kW	$T_1$ Nm	$P_1$ kW			
1 500	85.7	21.4																	
1 000	57.1	14.3			83.3	8.73			62.5	6.55	119	12.5	41.7	4.36	59.6	6.24	20.8	2.18	
750	42.9	10.7			88.7	6.97			66.5	5.23	125	9.80	44.4	3.48	62.4	4.90	22.2	1.74	
500	28.6	7.1	263	13.7	92.9	4.87	198	10.3	69.7	3.65	132	6.89	46.5	2.43	65.8	3.45	23.2	1.22	
300	17.1	4.3	281	8.84	103	3.24	211	6.63	77.4	2.43	141	4.42	51.6	1.62	70.3	2.21	25.8	0.81	
100	5.7	1.4	313	3.28	117	1.22	235	2.46	87.5	0.92	157	1.64	58.3	0.61	78.3	0.82	29.2	0.31	
50	2.9	0.7	340	1.78	131	0.69	255	1.33	98.1	0.51	170	0.89	65.4	0.34	84.9	0.44	32.7	0.17	

SJ 250				LOAD															
				250 kN				200 kN				150 kN				100 kN			
				RATIO		RATIO		RATIO		RATIO		RATIO		RATIO		RATIO			
$n_1$ [rpm]	LINEAR SPEED $v$ [mm/s]		RV2	RL2	RV2	RL2	RV2	RL2	RV2	RL2	RV2	RL2	RV2	RL2					
	RV2	RL2	$T_1$ Nm	$P_1$ kW	$T_1$ Nm	$P_1$ kW	$T_1$ Nm	$P_1$ kW	$T_1$ Nm	$P_1$ kW	$T_1$ Nm	$P_1$ kW	$T_1$ Nm	$P_1$ kW					
1 500	85.7	21.4																	
1 000	57.1	14.3																	
750	42.9	10.7			117	9.21			93.8	7.37			70.4	5.53	129	10.2	46.9	3.68	
500	28.6	7.1			124	6.51			100	5.21	205	10.7	74.7	3.91	137	7.15	49.8	2.61	
300	17.1	4.3	364	11.4	137	4.29	291	9.15	109	3.44	218	6.86	82.0	2.58	146	4.57	54.7	1.72	
100	5.7	1.4	419	4.39	156	1.64	335	3.51	125	1.31	252	2.63	93.7	0.98	168	1.76	62.5	0.65	
50	2.9	0.7	449	2.35	177	0.92	359	1.88	141	0.74	269	1.41	106	0.55	179	0.94	70.7	0.37	

## Screw jacks SJ Series - 2-starts acme screw

Following tables show the screw jack LINEAR SPEED  $v$  [mm/s] and relative TORQUE  $T_1$  [Nm] and POWER  $P_1$  [kW] on input shaft, with reference to the INPUT SPEED  $n_1$  [rpm], the RATIO (RV, RN, RL) and the LOAD [kN] applied on the screw jack.

Intermediate values for linear speed  $v$ , torque  $T_1$  and power  $P_1$  at different input speed can be calculated by linear interpolation of the figures stated in the table.

The figures in the tables refer to work with max. duty cycle of 30 % over 10 min time period or 20 % over 1 hour time period at 25°C environment temperature.

**ATTENTION!** The figures in the **red shaded area** indicate operational restrictions due to thermal limits. When the selection is made within such area, the duty cycle must be reduced or the greater size screw jack must be selected, in order to allow effective heat dissipation. For a better evaluation, please contact SERVOMECH Engineering Dpt.

SJ 300			LOAD															
			300 kN				250 kN				200 kN				100 kN			
			RATIO		RATIO		RATIO		RATIO		RATIO		RATIO		RATIO			
$n_1$ [rpm]	LINEAR SPEED $v$ [mm/s]		RV2	RL2	$T_1$ Nm	$P_1$ kW	$T_1$ Nm	$P_1$ kW	$T_1$ Nm	$P_1$ kW	$T_1$ Nm	$P_1$ kW	$T_1$ Nm	$P_1$ kW	$T_1$ Nm	$P_1$ kW		
	RV2	RL2																
1 500	62.1	20			117	18.4			97.9	15.4			78.3	12.3	92.5	14.5	39.1	6.15
1 000	41.4	13.3			129	13.5	246	25.7	108	11.3	197	20.6	86.2	9.03	98.3	10.3	43.1	4.51
750	31.0	10	308	24.2	139	10.9	257	20.2	115	9.07	206	16.2	92.4	7.25	103	8.08	46.2	3.63
500	20.7	6.7	329	17.2	148	7.77	274	14.4	124	6.48	219	11.5	99.0	5.18	110	5.75	49.5	2.59
300	12.4	4	359	11.3	158	4.95	299	9.39	131	4.13	239	6.51	105	3.30	120	3.76	52.5	1.65
100	4.1	1.3	402	4.21	190	1.99	335	3.51	158	1.65	268	2.80	126	1.32	138	1.40	63.2	0.66
50	2.1	0.7	439	2.30	212	1.11	366	1.92	177	0.92	293	1.53	141	0.74	146	0.77	70.6	0.37

SJ 350			LOAD															
			350 kN				300 kN				200 kN				100 kN			
			RATIO		RATIO		RATIO		RATIO		RATIO		RATIO		RATIO			
$n_1$ [rpm]	LINEAR SPEED $v$ [mm/s]		RV2	RL2	$T_1$ Nm	$P_1$ kW	$T_1$ Nm	$P_1$ kW	$T_1$ Nm	$P_1$ kW	$T_1$ Nm	$P_1$ kW	$T_1$ Nm	$P_1$ kW	$T_1$ Nm	$P_1$ kW		
	RV2	RL2																
1 500	62.1	20							123	19.3			82.1	12.9	93.9	14.7	41.0	6.45
1 000	41.4	13.3			157	16.4			134	14.1	205	21.5	89.5	9.37	103	10.7	44.8	4.69
750	31.0	10			168	13.2	320	25.1	144	11.34	213	16.7	96.2	7.56	107	8.37	48.1	3.78
500	20.7	6.7	399	20.9	183	9.57	342	17.9	157	8.20	228	12.0	104	5.47	114	5.98	52.2	2.73
300	12.4	4	441	13.9	194	6.11	378	11.9	167	5.24	252	7.92	111	3.49	126	3.96	55.6	1.75
100	4.1	1.3	499	5.23	235	2.46	428	4.48	201	2.11	285	2.92	134	1.41	143	1.49	67.1	0.70
50	2.1	0.7	540	2.82	260	1.36	462	2.42	223	1.17	308	1.61	148	0.78	154	0.81	74.4	0.39

SJ 400			LOAD															
			400 kN				300 kN				200 kN				100 kN			
			RATIO		RATIO		RATIO		RATIO		RATIO		RATIO		RATIO			
$n_1$ [rpm]	LINEAR SPEED $v$ [mm/s]		RV2	RL2	$T_1$ Nm	$P_1$ kW	$T_1$ Nm	$P_1$ kW	$T_1$ Nm	$P_1$ kW	$T_1$ Nm	$P_1$ kW	$T_1$ Nm	$P_1$ kW	$T_1$ Nm	$P_1$ kW		
	RV2	RL2																
1 500	64.3	20.7			168	26.4	291	45.7	126	19.8	194	30.4	83.9	13.2	96.2	15.2	42.0	6.59
1 000	42.9	13.8	418	43.8	185	19.3	313	32.8	139	14.5	209	21.9	92.3	9.67	104	10.9	46.2	4.83
750	32.1	10.3	439	34.5	195	15.3	329	25.9	146	11.5	219	17.2	97.4	7.65	110	8.62	48.7	3.83
500	21.4	6.9	464	24.3	214	11.2	348	18.2	161	8.41	232	12.1	108	5.61	116	6.07	53.6	2.80
300	12.9	4.1	516	16.2	229	7.20	387	12.2	172	5.40	258	8.11	115	3.60	129	4.05	57.3	1.80
100	4.3	1.4	589	6.17	276	2.89	442	4.63	207	2.17	295	3.08	138	1.45	142	1.54	69.0	0.72
50	2.1	0.7	646	3.38	313	1.64	485	2.54	234	1.23	323	1.69	156	0.82	162	0.85	78.2	0.41

SJ 600			LOAD															
			600 kN				500 kN				400 kN				200 kN			
			RATIO		RATIO		RATIO		RATIO		RATIO		RATIO		RATIO			
$n_1$ [rpm]	LINEAR SPEED $v$ [mm/s]		RV2	RL2	$T_1$ Nm	$P_1$ kW	$T_1$ Nm	$P_1$ kW	$T_1$ Nm	$P_1$ kW	$T_1$ Nm	$P_1$ kW	$T_1$ Nm	$P_1$ kW	$T_1$ Nm	$P_1$ kW		
	RV2	RL2																
1 500	75	24.1			294	46.1			245	38.4			196	30.8	221	34.7	97.9	15.4
1 000	50	16.1			317	33.2			264	27.7	482	50.5	211	22.1	241	25.3	106	11.1
750	37.5	12.1			342	26.8	640	50.3	285	22.4	512	40.2	228	17.9	256	20.1	114	8.94
500	25	8.0	816	42.7	377	19.7	680	35.6	314	16.4	544	21.5	251	13.1	272	14.3	126	6.57
300	15	4.8	886	27.9	405	12.7	739	23.2	337	10.6	591	18.6	270	8.48	295	9.28	135	4.24
100	5	1.6	1 041	10.9	498	5.21	867	9.08	415	4.35	694	7.27	332	3.48	347	3.63	166	1.74
50	2.5	0.8	1 128	5.91	547	2.86	940	4.92	456	2.39	752	3.94	365	1.91	376	1.97	182	0.95

## Screw jacks SJ Series - 2-starts acme screw

Following tables show the screw jack LINEAR SPEED  $v$  [mm/s] and relative TORQUE  $T_1$  [Nm] and POWER  $P_1$  [kW] on input shaft, with reference to the INPUT SPEED  $n_1$  [rpm], the RATIO (RV, RN, RL) and the LOAD [kN] applied on the screw jack.

Intermediate values for linear speed  $v$ , torque  $T_1$  and power  $P_1$  at different input speed can be calculated by linear interpolation of the figures stated in the table.

The figures in the tables refer to work with max. duty cycle of 30 % over 10 min time period or 20 % over 1 hour time period at 25°C environment temperature.

**ATTENTION!** The figures in the **red shaded area** indicate operational restrictions due to thermal limits. When the selection is made within such area, the duty cycle must be reduced or the greater size screw jack must be selected, in order to allow effective heat dissipation. For a better evaluation, please contact SERVOMECH Engineering Dpt.

SJ 800			LOAD															
			800 kN				600 kN				400 kN				200 kN			
			RATIO		RATIO		RATIO		RATIO		RATIO		RATIO		RATIO			
$n_1$ [rpm]	LINEAR SPEED $v$ [mm/s]		RV2	RL2	$T_1$ Nm	$P_1$ kW	$T_1$ Nm	$P_1$ kW	$T_1$ Nm	$P_1$ kW	$T_1$ Nm	$P_1$ kW	$T_1$ Nm	$P_1$ kW	$T_1$ Nm	$P_1$ kW		
	1 500	60															19.4	
1 000	40	13.0			366	38.3	631	66.1	274	28.7	421	44.0	183	19.1	210	22.2	91.4	9.57
750	30	9.7	883	69.4	392	30.8	663	52.0	294	23.1	442	34.7	196	15.4	221	17.3	98.1	7.70
500	20	6.5	941	49.3	437	22.9	705	36.9	328	17.2	470	24.6	219	11.4	235	12.3	109	5.72
300	12	3.9	1 054	33.1	474	14.9	790	24.8	355	11.2	527	16.6	237	7.44	263	8.28	118	3.72
100	4	1.3	1 221	12.8	587	6.15	915	9.59	440	4.61	611	6.39	294	3.07	305	3.20	147	1.54
50	2	0.6	1 325	6.94	645	3.38	994	5.20	483	2.53	662	3.47	322	1.69	331	1.73	161	0.84

SJ 1000			LOAD															
			1000 kN				800 kN				600 kN				400 kN			
			RATIO		RATIO		RATIO		RATIO		RATIO		RATIO		RATIO			
$n_1$ [rpm]	LINEAR SPEED $v$ [mm/s]		RV2	RL2	$T_1$ Nm	$P_1$ kW	$T_1$ Nm	$P_1$ kW	$T_1$ Nm	$P_1$ kW	$T_1$ Nm	$P_1$ kW	$T_1$ Nm	$P_1$ kW	$T_1$ Nm	$P_1$ kW		
	1 500	68.6															22.2	
1 000	45.7	14.8			519	54.3			415	43.5	703	73.6	311	32.6	468	49.1	207	21.7
750	34.3	11.1			556	43.7	983	77.2	445	35.0	737	57.9	334	26.2	491	38.6	223	17.5
500	22.9	7.4	1 324	69.3	612	32.0	1 059	55.4	490	25.6	794	41.6	367	19.2	529	27.7	245	12.8
300	13.7	4.4	1 471	46.2	676	21.3	1 176	37.0	541	17.0	882	27.7	406	12.8	588	18.5	271	8.50
100	4.6	1.5	1 745	18.3	834	8.73	1 396	14.6	667	6.99	1 047	11.0	500	5.24	698	7.31	334	3.49
50	2.3	0.7	1 908	9.99	926	4.85	1 526	7.99	741	3.88	1 145	5.99	556	2.91	763	4.00	370	1.94

### Total efficiency of screw jack with 2-starts acme screw

$\eta$	SJ 5				SJ 10			SJ 25			SJ 50			SJ 100			SJ 150		
	RH2	RV2	RN2	RL2	RV2	RN2	RL2	RV2	RN2	RL2	RV2	RN2	RL2	RV2	RN2	RL2	RV2	RN2	RL2
1 500	0.48	0.45	0.41	0.33	0.50	0.38	0.34	0.47	0.38	0.34	0.46	0.40	0.33	0.46	0.40	0.33	0.49	0.39	0.36
1 000	0.45	0.43	0.38	0.31	0.47	0.37	0.32	0.45	0.36	0.33	0.43	0.37	0.30	0.43	0.37	0.30	0.46	0.36	0.33
750	0.44	0.41	0.37	0.29	0.46	0.35	0.30	0.44	0.35	0.32	0.42	0.35	0.29	0.42	0.35	0.29	0.45	0.34	0.32
500	0.41	0.40	0.36	0.28	0.43	0.34	0.28	0.41	0.33	0.30	0.39	0.34	0.28	0.40	0.33	0.27	0.43	0.33	0.31
300	0.40	0.39	0.33	0.27	0.41	0.32	0.27	0.39	0.31	0.27	0.37	0.32	0.25	0.36	0.32	0.25	0.39	0.31	0.27
100	0.36	0.36	0.30	0.23	0.37	0.28	0.22	0.35	0.27	0.24	0.34	0.28	0.22	0.33	0.28	0.22	0.36	0.27	0.24
50	0.35	0.34	0.29	0.22	0.37	0.27	0.21	0.34	0.26	0.22	0.32	0.26	0.19	0.31	0.26	0.20	0.34	0.24	0.21
AT START	0.32	0.32	0.28	0.21	0.33	0.26	0.20	0.31	0.23	0.20	0.29	0.24	0.18	0.28	0.23	0.17	0.30	0.21	0.19

$\eta$	SJ 200		SJ 250		SJ 300		SJ 350		SJ 400		SJ 600		SJ 800		SJ 1000	
	RV2	RL2	RV2	RL2	RV2	RL2	RV2	RL2	RV2	RL2	RV2	RL2	RV2	RL2	RV2	RL2
1 500	0.48	0.36	0.47	0.34	0.43	0.33	0.42	0.31	0.42	0.31	0.43	0.31	0.40	0.29	0.41	0.29
1 000	0.46	0.33	0.44	0.31	0.40	0.30	0.39	0.28	0.39	0.29	0.40	0.29	0.36	0.27	0.37	0.27
750	0.44	0.31	0.42	0.29	0.38	0.28	0.37	0.26	0.37	0.27	0.37	0.27	0.35	0.25	0.36	0.25
500	0.41	0.29	0.40	0.27	0.36	0.26	0.35	0.24	0.35	0.25	0.35	0.24	0.32	0.23	0.33	0.23
300	0.39	0.26	0.37	0.25	0.33	0.24	0.31	0.23	0.32	0.23	0.32	0.23	0.32	0.23	0.30	0.21
100	0.35	0.23	0.33	0.22	0.30	0.20	0.28	0.19	0.28	0.19	0.28	0.19	0.25	0.17	0.25	0.17
50	0.32	0.21	0.30	0.19	0.27	0.18	0.26	0.17	0.25	0.17	0.25	0.17	0.23	0.15	0.23	0.15
AT START	0.28	0.19	0.26	0.17	0.23	0.15	0.21	0.14	0.21	0.13	0.20	0.13	0.18	0.11	0.18	0.11



# Screw jacks SJ Series - overall dimensions

## Model A - TRAVELLING SCREW

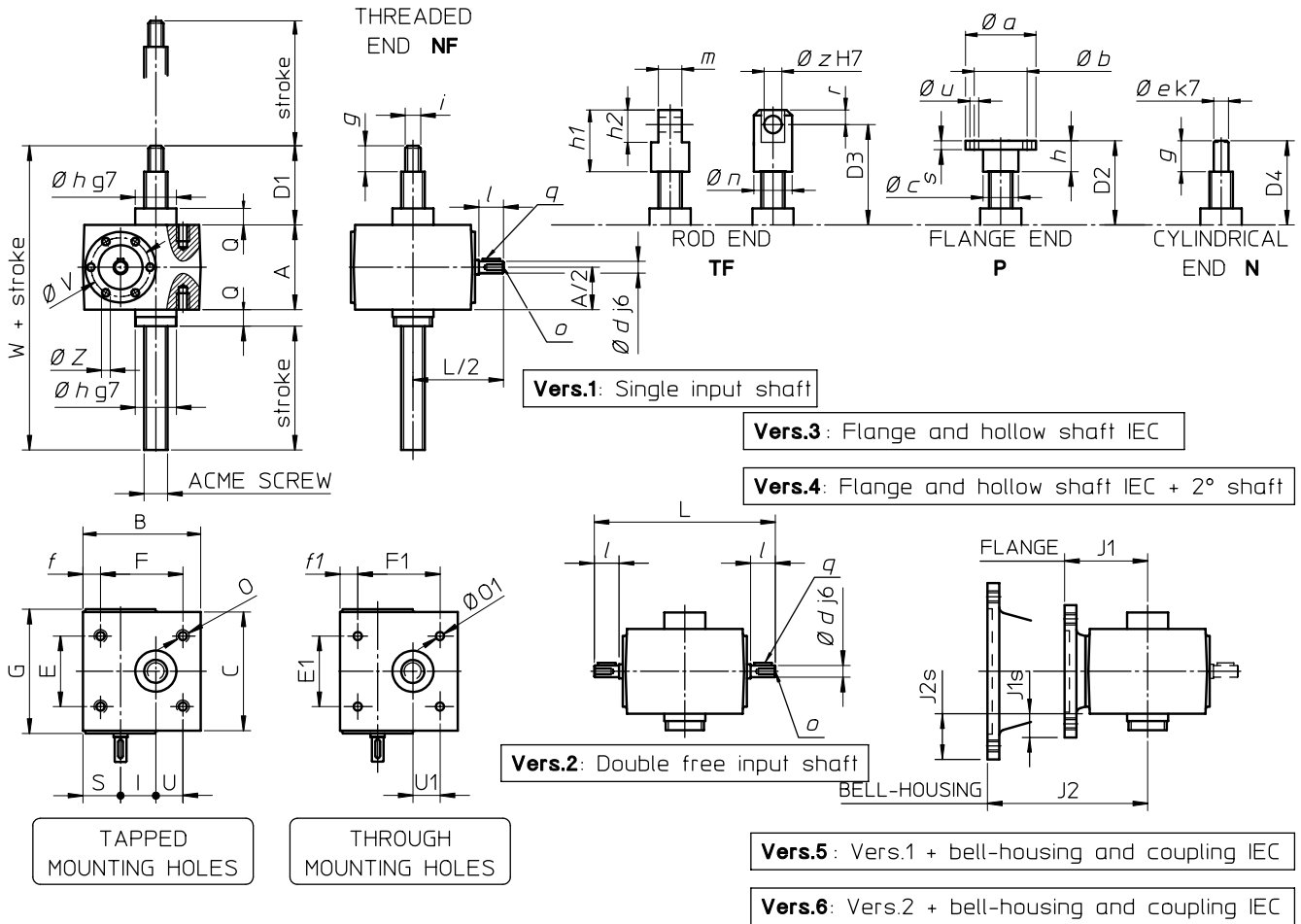

## Model B - TRAVELLING NUT

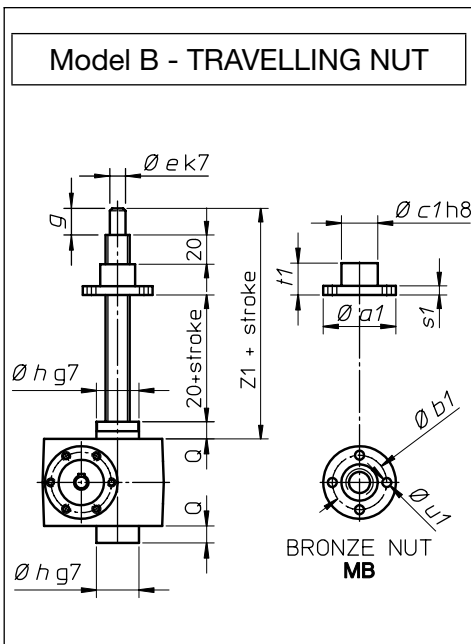

### PROTECTIVE TUBE T

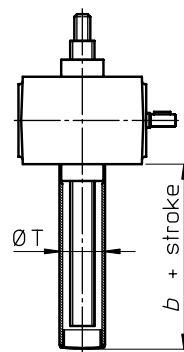

### ANTI-TURN DEVICE AR

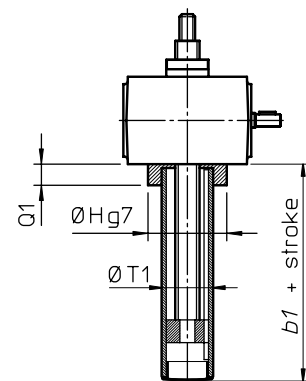

SIZE	SJ 5	SJ 10	SJ 25	SJ 50	SJ 100	SJ 150	SJ 200	SJ 250
ØT	35	40	50	65	102	102	130	130
exec. T	37	43	48	57	65	65	75	75
b								
exec. T + SN	87	93	128	137	155	155	155	155
exec. T + FCM	86	93	98	-	-	-	-	-
exec. T + FCP	87	93	98	107	115	115	115	115
ØH	55	70	85	115	-	-	-	-
Q1	21	18	25	32	-	-	-	-
ØT1	45	55	70	90	100	100	130	130
b1								
exec. AR	86	88	105	102	135	145	135	145
exec. AR + FCP	96	98	115	122	135	145	135	145



## Screw jacks SJ Series - overall dimensions

SIZE	SJ 5	SJ 10	SJ 25	SJ 50	SJ 100	SJ 150	SJ 200	SJ 250
ACME SCREW	Tr 18x4	Tr 22x 5	Tr 30x6	Tr 40x7	Tr 55x9	Tr 60x12	Tr 70x12	Tr 80x12
A	62	76	82	118	160	164	176	176
B	100	110	160	200	220	282	280	280
C	86	96	130	160	170	201	230	230
D1 (min.)	51	62	81	90	108	108	118	118
D2 (min.)	52	63	83	92	110	110	120	120
D3 (min.)	77	93	118	137	160	190	210	210
D4 (min.)	51	62	81	90	108	108	118	118
E	52	63	81	115	134	150	180	180
E1	56	80	102	130	120	150	180	180
F	60	78	106	150	175	220	230	230
F1	80	85	131	165	180	220	230	230
G	90	100	136	165	165	205	—	—
I	25	30	50	63	63	80	90	90
L	135	165	221.5	269	269	330	350	350
O	M8, depth 14	M8, depth 15	M10, depth 15	M12, depth 16	M20, depth. 30	M30, depth 45	M30, depth 45	M30, depth 45
∅ O1	9	9	11	13	17	28	32	32
Q	12	18	23	32	40	40	40	40
S	37	40	50	59	74	94	75	75
U	21	29	42	63	60	75	90	90
U1	28	30	48	60	63	75	90	90
∅ V	46	46	64	63	63	74	—	—
W	125	156	186	240	308	312	334	334
Z	M6, depth 13 (4 holes at 90°)	M5, depth 10 (6 holes at 60°)	M5, depth 10 (6 holes at 60°)	M6, depth 14 (6 holes at 60°)	M6, depth 14 (6 holes at 60°)	M6, depth 14 (6 holes at 60°)	—	—
Z1	111	127	151	185	228	228	268	248
∅ a	68	75	100	120	150	150	180	180
∅ a1	68	75	100	120	130	150	180	190
∅ b	45	55	75	85	110	110	130	130
∅ b1	50	56	75	90	105	120	140	150
∅ c	25	30	40	50	70	70	85	85
∅ c1	30	40	50	60	75	80	100	110
∅ d	9	14	19	24	24	28	30	30
∅ e	12	15	20	30	40	40	50	60
f	23	21	36	35	22	29	25	25
f1	10	15	17	17	20	29	25	25
g	19	24	38	38	48	48	58	58
h	20	25	40	40	50	50	60	60
∅ h	30	38.7	46	60	90	90	120	120
h1	60	75	100	120	140	180	210	210
h2	30	40	50	70	80	100	120	120
i	M12x1.75	M16x1.5	M20x1.5	M30x2	M42x3	M42x3	M56x3	M56x3
l	20	30	40	50	50	60	55	55
m	20	25	30	40	50	60	75	75
∅ n	32	38	48	68	78	90	108	108
o	M4, depth 8	M6, depth 14	M8, depth 16	M8, depth 16	M8, depth 16	M8, depth 16	M10, depth 18	M10, depth 18
q	3x3x15	5x5x20	6x6x30	8x7x40	8x7x40	8x7x40	8x7x45	8x7x45
r	15	20	25	35	40	50	60	60
s	8	10	12	15	20	20	25	25
s1	12	12	15	25	20	30	35	30
t1	40	45	50	75	100	100	130	110
∅ u, n° holes	∅ 7, 4 holes	∅ 9, 4 holes	∅ 11, 4 holes	∅ 17, 4 holes	∅ 21, 4 holes	∅ 21, 4 holes	∅ 26, 6 holes	∅ 26, 6 holes
∅ u1, n° holes	∅ 7, 4 holes	∅ 9, 4 holes	∅ 11, 4 holes	∅ 17, 4 holes	∅ 17, 4 holes	∅ 21, 4 holes	∅ 26, 6 holes	∅ 18, 4 holes
∅ z	14	20	25	35	40	50	60	60
J1	56 B5/B14: 57.5	63 B5/B14: 62	63/71 B5: 102	80 B5: 100	80 B5: 100	80/90 B5: 120	100/112 B5: 170	100/112 B5: 170
J1s	56 B5: 29 56 B14: 9	63 B5: 32 63 B14: 7	63 B5: 29 71 B5: 39	80 B5: 41	80 B5: 20	80/90 B5: 18	100/112 B5: 37	100/112 B5: 37
J2	63 B5: 98	71 B5: 122 71 B14: 131	80 B5: 182 80 B14: 176 90 B5: 182 90 B14: 182	90 B5: 200 90 B14: 200 100 B5: 220 100 B14: 220	90 B5: 200 90 B14: 200 100/112 B5: 220 100/112 B14: 220	100/112 B5: 240 100/112 B14: 240	132 B5: 292	132 B5: 292
J2s	63 B5: 39	71 B5: 42 71 B14: 15	80 B5: 59 80 B14: 19 90 B5: 59 90 B14: 29	90 B5: 41 90 B14: 11 100 B5: 66 100 B14: 21	90 B5: 20 90 B14: — 100/112 B5: 45 100/112 B14: —	100/112 B5: 43 100/112 B14: —	132 B5: 62	132 B5: 62

# Screw jacks SJ Series - overall dimensions

## Model A - TRAVELLING SCREW

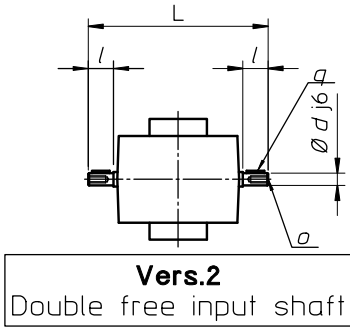
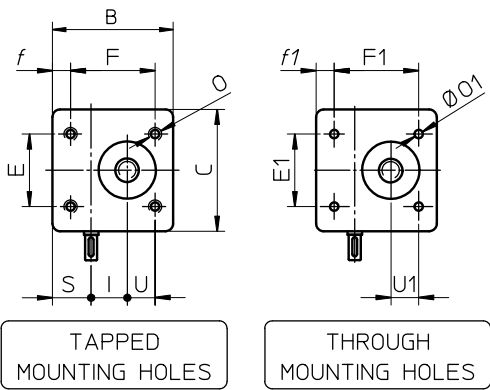
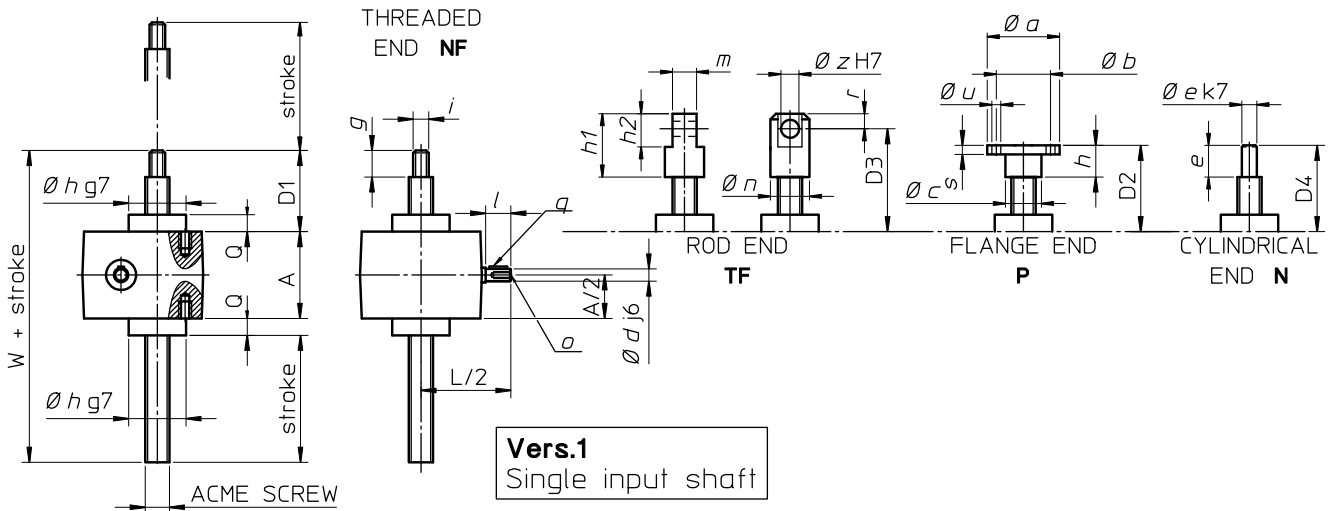

### PROTECTIVE TUBE T

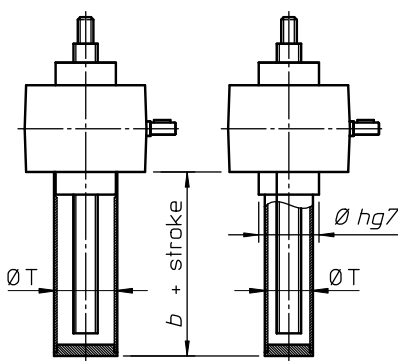

### ANTI-TURN DEVICE AR

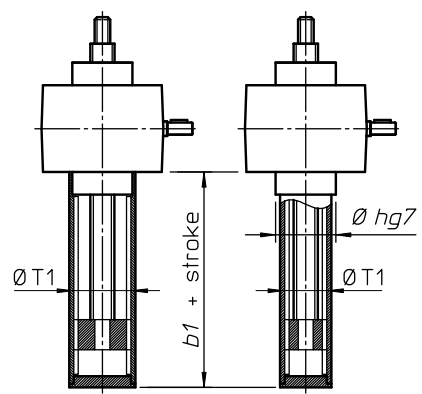

- SJ 300
- SJ 350
- SJ 400
- SJ 600
- SJ 800
- SJ 1000

- SJ 300
- SJ 350
- SJ 400
- SJ 600
- SJ 800
- SJ 1000

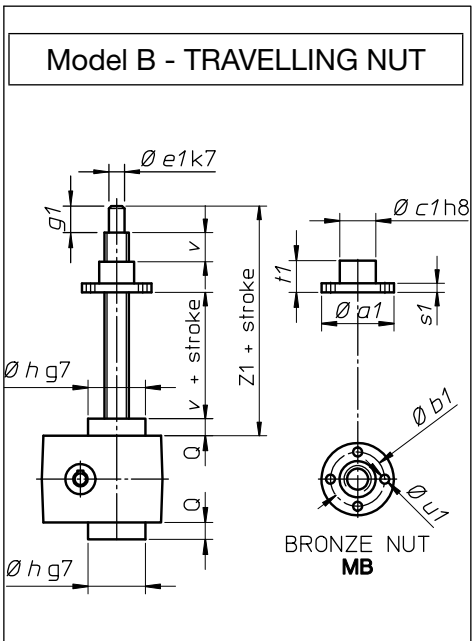

SIZE	SJ 300	SJ 350	SJ 400	SJ 600	SJ 800	SJ 1000
ØT	150	150	200	200	200	200
exec. T	110	110	110	110	130	130
b exec. T + SN	210	210	210	210	250	250
exec. T + FCP	160	160	160	160	190	190
ØT1	160	160	200	200	273	273
b1 exec. AR	190	200	140	150	180	190
exec. AR + FCP	190	200	170	180	210	220

3

## Screw jacks SJ Series - overall dimensions

SIZE	SJ 300	SJ 350	SJ 400	SJ 600	SJ 800	SJ 1000
ACME SCREW	Tr 90x12	Tr 100x12	Tr 100x12	Tr 120x14	Tr 140x14	Tr 160x16
A	230	230	270	270	370	370
B	320	320	418	418	610	610
C	250	250	330	330	500	500
D1 (min.)	158	158	158	178	220	235
D2 (min.)	160	160	160	170	210	210
D3 (min.)	290	290	290	340	410	430
D4 (min.)	210	210	210	240	260	260
E	200	200	230	230	—	—
E1	200	200	230	230	360	360
F	270	270	355	355	—	—
F1	270	270	355	355	510	510
I	110	110	140	140	200	200
L	390	390	490	490	780	780
O	M30, depth 45	M30, depth 45	M30, depth 45	M30, depth 45	—	—
∅ O1	32	32	32	32	60	60
Q	50	50	50	50	60	60
S	85	85	117	117	170	170
U	100	100	135	135	—	—
U1	100	100	135	135	190	190
W	438	438	598	618	650	665
Z1	340	345	345	375	530	530
∅ a	250	278	278	298	378	378
∅ a1	230	230	230	280	320	320
∅ b	180	220	220	240	300	300
∅ b1	190	190	190	235	270	270
∅ c	115	150	150	170	210	210
∅ c1	150	150	150	180	210	210
∅ d	40	40	55	55	70	70
e	120	120	120	150	150	150
∅ e	70	85	85	100	120	140
∅ e1	70	70	70	90	120	130
f	25	25	37	37	—	—
f1	25	25	37	37	50	50
g	68	68	68	88	110	125
g1	80	80	80	85	120	120
h	70	70	70	80	100	100
∅ h	150	150	210	210	300	300
h1	280	280	280	350	440	460
h2	160	160	160	200	280	280
i	M70x6	M70x6	M70x6	M90x6	M110x6	M125x6
l	65	65	75	75	130	130
m	100	100	100	120	155	155
∅ n	138	138	138	168	216	216
o	M10, depth 22	M10, depth 22	M12, depth 28	M12, depth 28	M14, depth 30	M14, depth 30
q	12x8x55	12x8x55	16x10x60	16x10x60	20x12x110	20x12x110
r	80	80	80	100	140	140
s	40	40	40	50	60	60
s1	45	45	45	55	80	80
t1	135	135	135	160	250	250
∅ u, n° holes	∅ 29, 6 holes	∅ 29, 6 holes	∅ 29, 6 holes	∅ 32, 6 holes	∅ 52, 6 holes	∅ 52, 6 holes
∅ u1, n° holes	∅ 20, 4 holes	∅ 20, 4 holes	∅ 20, 4 holes	∅ 25, 4 holes	∅ 25, 6 holes	∅ 25, 6 holes
v	40	40	40	40	50	50
∅ z	80	80	80	100	140	140