

WAFER TYPE PROCESS VALVE T 211-C



PTFE-lined wafer type valve for chemically toxic and highly corrosive media.

TECHNICAL DATA

Nominal diameter:	DN (40)50 - DN 300
Face-to-face:	EN 558 Table 20
Flange accommodation:	EN 1092 PN 10/16 ASME Class 150
Flange Surface Design:	EN 1092 Form A/B ASME RF, FF
Top flange:	EN ISO 5211
Marking:	EN 19 PAS 1085
Tightness check:	EN 12266 (Leakage rate A)
Temperature range:	-40°C to +200°C (depending on working pressure)
Operating pressure:	max. 10 bar (16 bar special version)
Vacuum:	up to 1 mbar absolute, (with silicon elastomer inserts) from -10°C to +160°C

Valve Design
acc. to PAS 1085

FEATURES

- Environmental protection via EBRO-Safety seal
- TA-Luft/ VDI 2440, RWTÜV certified
- Isolation height according to plant prescription
- Maintenance-free
- Can be disassembled, material-specific recycling possible
- Material conform to FDA to EG 1935/2004

DESIGN FEATURES

- Optimized low torques
- FEM dimensioned components
- Double flat shaft acc. to EN standards
- Shaft/ disc: duplex (one-piece lost-wax casting)
- Triple shaft bearing

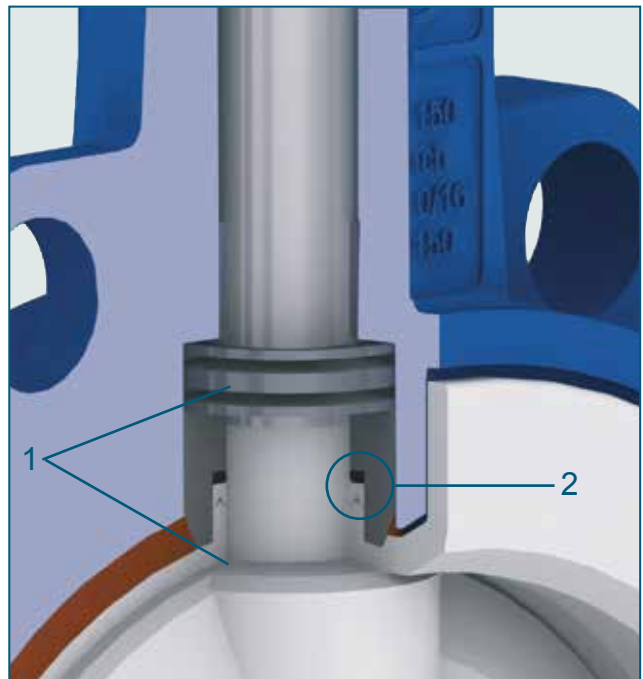

Safety seal at both shaft ends:

1. Primary sealing by means of a Belleville spring washer, transmitting prestress on the spherical segment area.
2. Secondary sealing of the shaft by means of PTFE-Chevron and O-ring.

WAFER TYPE PROCESS VALVE T 211-C

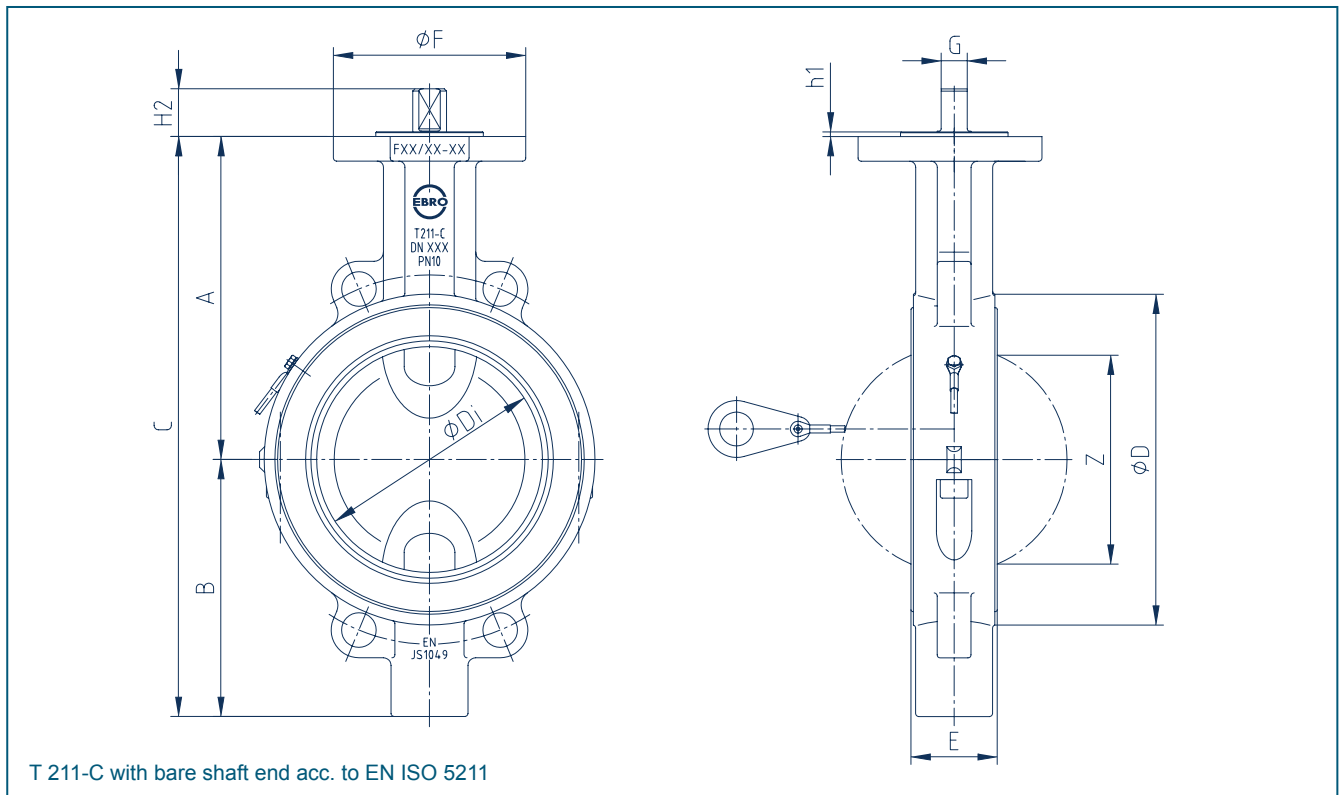

DN [mm]	Size [in]	Dimensions [mm]											Weight [kg]	
		A	B	C	ØD	ØDi	E	Flange	ØF	G	h1	H2		Z
40/50	1½ 2	126	95	221	112	49	43	F07	90	11	3	22	25	3,5
65	2½	150	103	253	120	61	46	F07	90	11	3	22	41	4
80	3	157	124	281	138	80	46	F07	90	14	3	26	66	6
100	4	180	135	315	160	100	52	F07	90	14	3	26	85	8
150	6	210	167	377	215	151	56	F10	125	17	3	31	141	11
200	8	240	190	430	269	196	60	F12	150	17	3	31	187	18
250	10	275	232	507	324	248	68	F12	150	22	3	40,5	239	32
300	12	298	260	558	374	293	78	F14	175	22	4	41,5	283	46

Subject to change without notice

WAFER TYPE PROCESS VALVE T 211-C

MATERIAL SPECIFICATION AND PARTS LIST

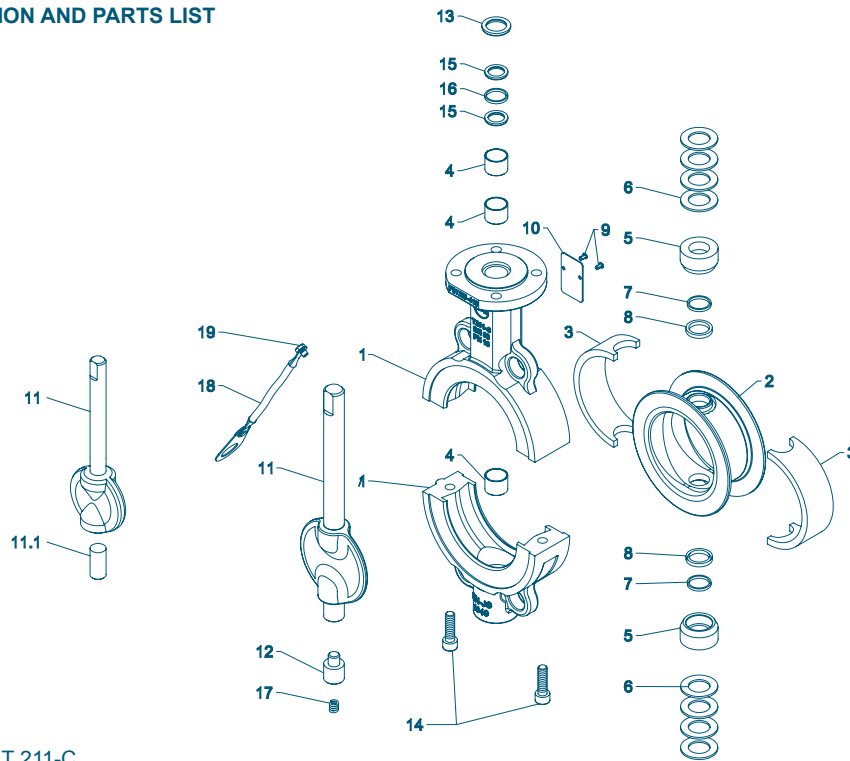

Wafer type process valve T 211-C

Pos.	Description	Material	Material-No.	ASTM	Pos.	Description	Material	Material-No.	ASTM
1	Body				11**	Disc/Shaft (one-piece type)			
	Nodular Cast Iron	EN-JS 1049	EN 1563	A395		St. Steel/St. Steel	X2CrNiMo22-5-3/	1.4469/	Duplex
2**	Seat						X2CrNiMo22-5-3	1.4469	
	PTFE	Polytetrafluorethylene	PTFE			St.Steel/PFA coated	X2CrNiMo22-5-3/	1.4469/	Duplex/
	M.-PTFE	Polytetrafluorethylene	modified				X2CrNiMo22-5-3/ Perfluoralkoxy		
	Cond.-PTFE	Polytetrafluorethylene	conductive			St. Steel/PFA conductive	X2CrNiMo22-5-3/	1.4469/	Duplex/
3**	Elastomer insert						X2CrNiMo22-5-3/ Perfluoralkoxy		
	Silicon	Silicon - rubber	MVQ	VMQ	11.1	Lower shaft (DN 40/50 only)			
4	DU-bearing					Stainless Steel	X2CrNiMoN22-5-3	1.4469	Duplex
	Steel / PTFE coated				12	Lower shaft stup (DN 65 - DN 200 only)			
5**	Trust collar					Stainless Steel	X39CrMo 17-1	1.4122	
	Stainless Steel	X5CrNiMo17-12-2	1.4401	316	13	Wiper ring			
6	Belleville spring washer					PTFE	Polytetrafluorethylene	PTFE	PTFE
	Stainless Steel	X12CrNi177	1.4568	631	14	Screw			
7**	O-Ring					Stainless Steel	A4-70		
	FPM	Fluorocarbon rubber	FPM	FKM	15**	Thrust ring			
8**	Chevron seal					PTFE	Polytetrafluorethylene	PTFE	PTFE
	PTFE	Polytetrafluorethylene	PTFE	PTFE	16**	O-Ring			
9	Groove pin					FPM	Fluorocarbon rubber		FKM
	Stainless Steel	A2			17	Spiral spring			
10	Type plate					Spring steel	X10CrNi 18-8	1.4310	301
	Stainless Steel				18	Buttstrap			
					19	Screw			
						Stainless Steel	A2-70		

Above-mentioned materials of the basic version, other materials upon request

** recommended spare parts

Subject to change without notice

WAFER TYPE PROCESS VALVE T 211-C

TORQUE

- The torque values specified (Md) are based on dry media and are measured with air at a temperature of 20 °C
- The values specified are based on the initial breakaway torque (disc disengages from seat, torque then drops)
- Dynamic torque specification available upon request

Regarding the dimensioning of actuators, please contact our engineers.

DN (mm)	40/50	65	80	100	150	200	250	300
Size (in)	1½ 2	2½	3	4	6	8	10	12
MD (Nm)	35	35	55	70	135	170	320	380
MAST (Nm)*	105	105	250	250	480	480	1020	1020

*Maximum torques (Nm)

PRESSURE/TEMPERATURE DIAGRAM

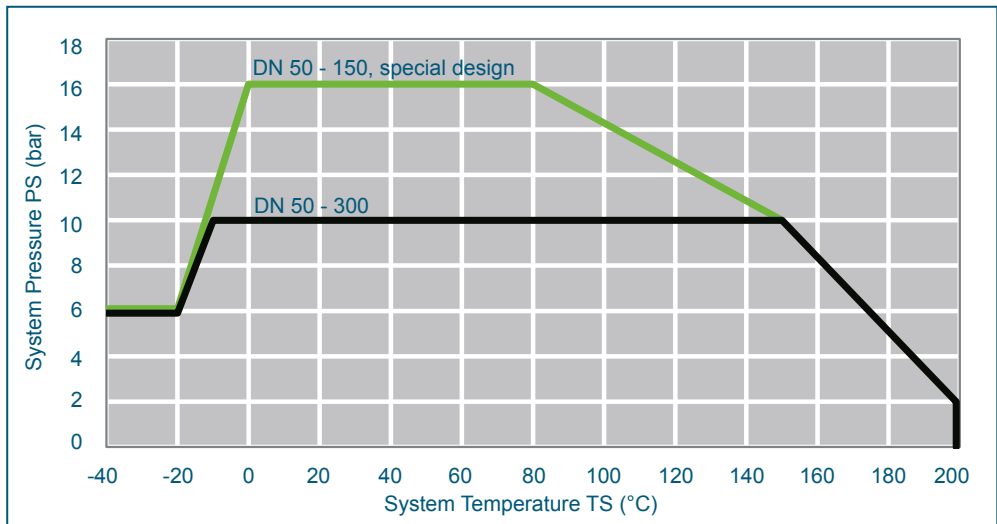

Pressure-Temperature-Diagram for valves with silicone elastomer inserts

Service limitation with Fluor carbon inserts (FPM) from -10°C up to +120°C

Service limitation with EPDM elastomer inserts from -10°C up to +180°C

Vacuum service to 1mbar absolute, from -10°C up to +160°C. Valve installation between flanges

K_V-VALUES

- The K_V-value [m³ per hour] is the flow of water at a temperature of 5°C to 30°C (41°F to 86°F) at Δp of 1 bar

- The K_V-values specified are based on tests carried out by the Delfter Hydraulics Laboratories, the Netherlands

- Permissible velocity of flow
V_{max} 4,5 m/s for liquids,
V_{max} 70 m/s for gases

- The throttle function is linear at an angle 30° to 70°

- Avoid cavitation

For further values, please contact our engineers.

DN [mm]	Size [in]	Opening angle α°							
		20°	30°	40°	50°	60°	70°	80°	90°
1) K_V-values metal disc									
40/50	1½ 2	4	5	16	35	57	81	101	114
65	2½	5	8	25	56	99	153	216	287
80	3	13	12	30	69	131	216	328	467
100	4	13	25	61	121	207	319	459	627
150	6	50	94	171	303	509	810	1226	1778
200	8	137	149	344	696	1178	1764	2426	3137
250	10	178	291	562	1021	1699	2626	3832	5348
300	12	395	378	820	1638	2751	4079	5538	7049
2) K_V-values PFA-disc									
40/50	1½ 2	2	4	13	25	40	53	63	66
65	2½	3	9	26	48	74	98	117	126
80	3	4	14	38	71	108	143	171	186
100	4	6	16	48	95	151	209	262	303
150	6	18	60	161	317	526	787	1096	1452
200	8	125	176	395	756	1234	1807	2449	3136
250	10	138	333	644	1103	1744	2599	3702	5086
300	12	203	462	872	1479	2329	3471	4950	6814

Subject to change without notice



www.ebro.cn

www.ebro-armaturen.com

01.2019

ebrobj@ebro.cn

post@ebro-armaturen.com