

调心螺母丝杆升降机

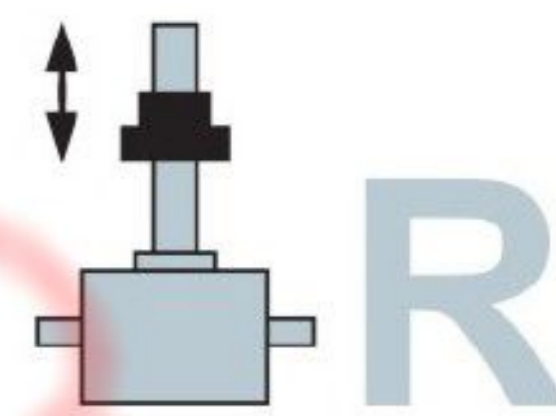

# 自对准螺母



适用于旋转版 R 的螺母



自对准螺母 SJA-.-PM

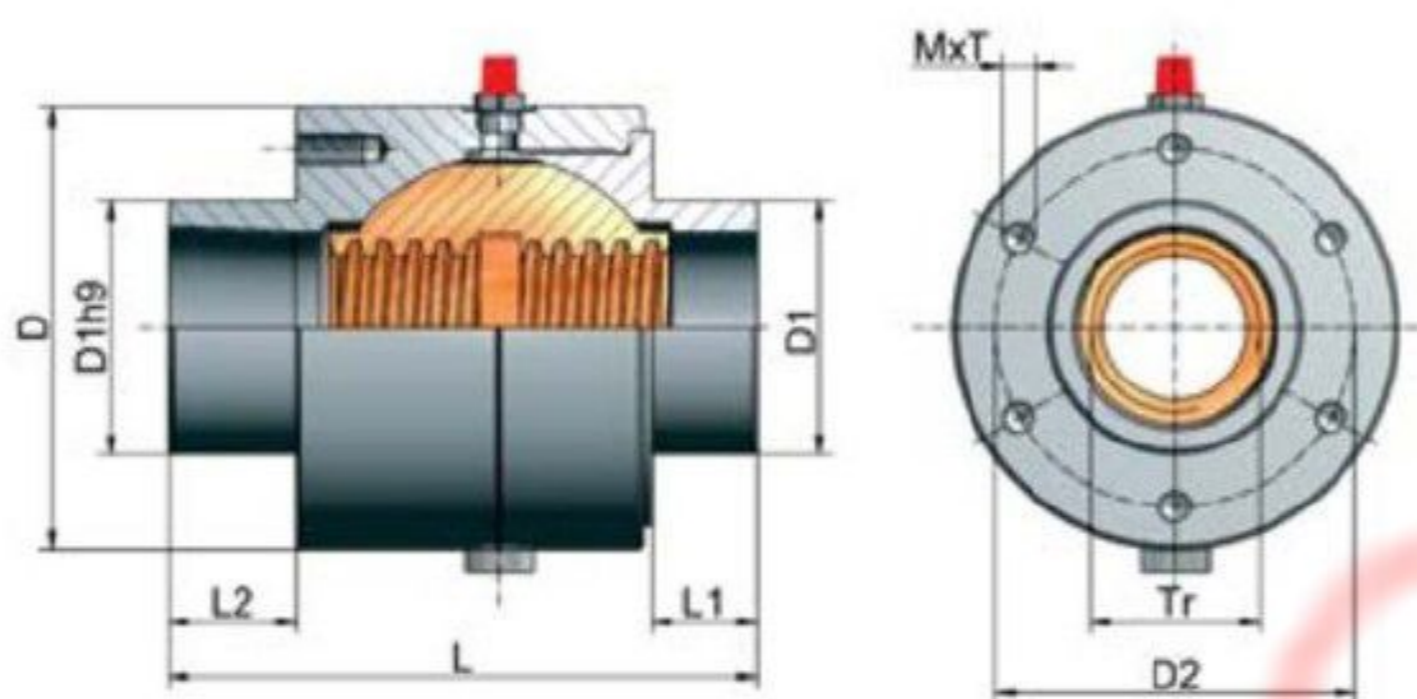

- 优点**
- 角度补偿最大  $\pm 3^\circ$
  - 油口或连接螺纹至中央润滑
  - 可以连接防尘套

部件号	螺纹	D	D1	D2
SJA5-PM	Tr 18x4	52	29	40
SJA10-PM	Tr 20x4	74	39	60
SJA20-PM	Tr 30x6	88	46	70
SJA50-PM	Tr 40x7	105	60	85
SJA80-PM	Tr 50x8	148	85	120
SJA100-PM	Tr 60x9	165	90	125
SJA200-PM	Tr 80x12	225	120	170
SJA300-PM	Tr 100x16	280	145	215

部件号	M x T	L	L1	L2	LS <sup>2)</sup>	Kg
SJA5-PM	M5x12	78	13	21	123	0.66
SJA10-PM	M6x12	83	13	24	128	1.49
SJA20-PM	M6x12	95	13	27	158	2.36
SJA50-PM	M8x16	129	15	30	212	5.04
SJA80-PM	M10x20	190	15	45	298	15.1
SJA100-PM	M12x24	210	15	45	330	21.9
SJA200-PM	M16x32	224	20	40	369	47.0
SJA300-PM	M20x40	275	20	40	455	94

2) 总长度含 SIFA 安全螺母

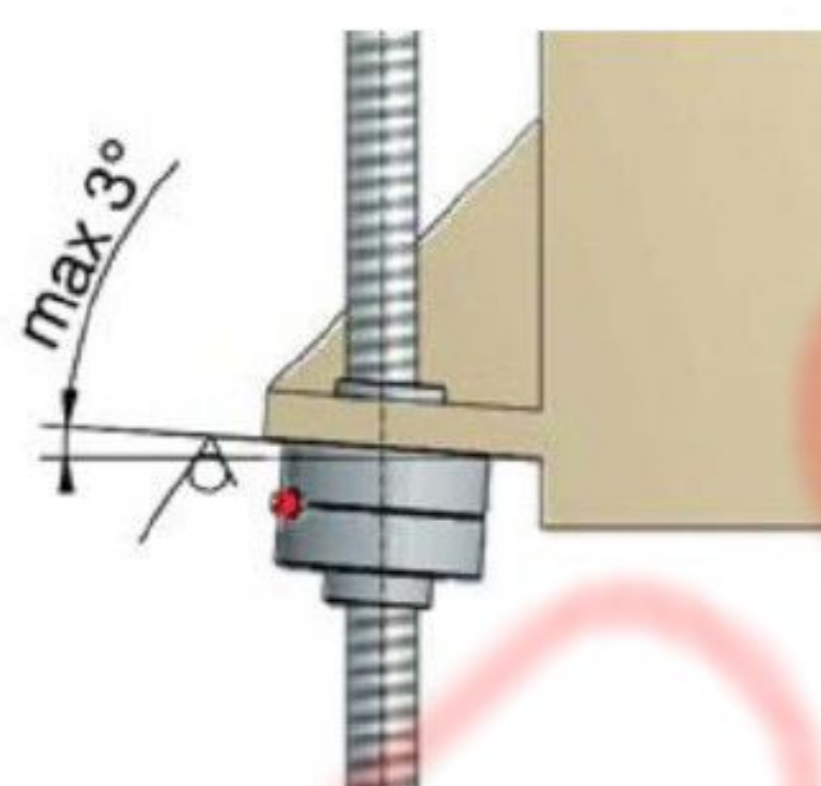

**应用:**  
 (焊接) 制品通常展现出角度误差, 从而导致梯形螺杆螺母很快发生磨损。自对准螺母 PM 可以补偿连接面上小角度误差, 最大可补偿  $\pm 3^\circ$ 。  
 较大的油腔增加了维护间隔, 延长了使用寿命。

**注意:**  
 自对准螺母不能补偿螺杆间或螺杆与导轨间的平行度误差。请注意确保精确对齐。因此, 齿轮箱的连接面必须与导轨正好成直角。

**带螺纹油口**  
 从 Tr 40x7 开始, 螺纹距为  $1/8'' / 1/4''$

**材质**  
 外壳: GG 25 (灰口铸铁)  
 球形螺母: Rg7 (青铜)

**安全螺母 SIFA**  
 可按需提供自对准螺母。

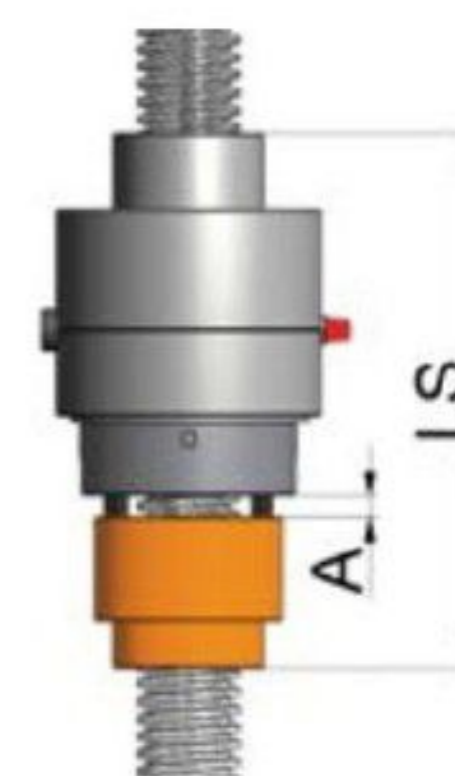

2017  
版

© 2017 DONGKING DRIVE 版权所有 翻印必究



**天津市祥嘉减速机械有限公司**

**Tianjin Xiangjia reducer Co. LTD**

**天津南开区密云路北方城 2 区 6 栋 130 号**

**No. 130, Building 6, Area 2, North Fangcheng, Miyun Road, Nankai District, Tianjin**

**邮 编：300112**

**邮 箱：jsj@tjxiangjia.com**

**电 话：022-27368677 27340469**

**传 真：022-27368677 27257226**



有关本公司产品目录的内容，随着技术进步等，将会有变更，望谅解！  
Along with the technology advanced etc., the product of the manual of DONGKING will be changed, please forgive.