

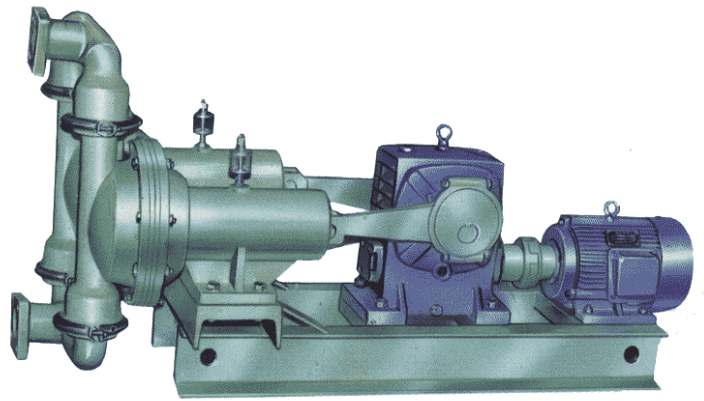

DBY Electric Diaphragm Pump

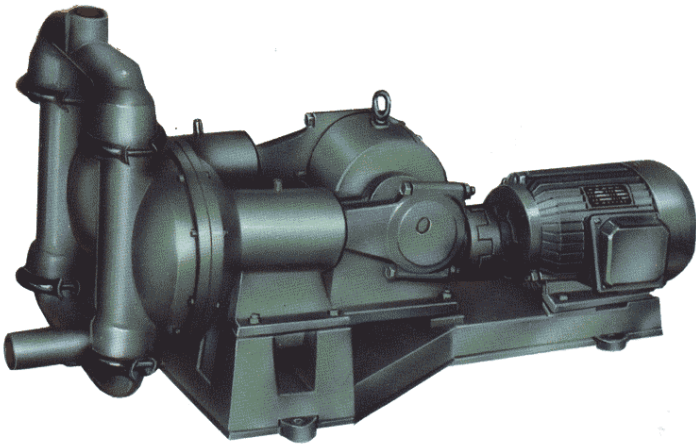

DBY series electric diaphragm pumps are driven with cycloid needle gear reducer in stead of traditional worm & wheel mechanism. Widely used for leak proof applications in industries like petrochemical, chemical, metallurgy and ceramics etc..

V-FLO PUMPS & SYSTEMS COMPANY LIMITED

WWW.V-FLO.COM

FEATURES

- Compact design and light construction with leak proof and low noise operation.
- High efficiency and allowable for idle operation.
- Liquid temperature up to 150°C.
- Self-priming with 7 meters' suction head.
- Capable of handling liquids with solid particles and slurries.
- Wide range of diaphragm materials including: neoprene, fluoride rubber, butadiene nitrile rubber and TEFLON.
- Liquid contacted materials available: cast iron, stainless steel, rubber liner and aluminum alloy.
- Explosion proof motor (B3d) available.

Performance Curves

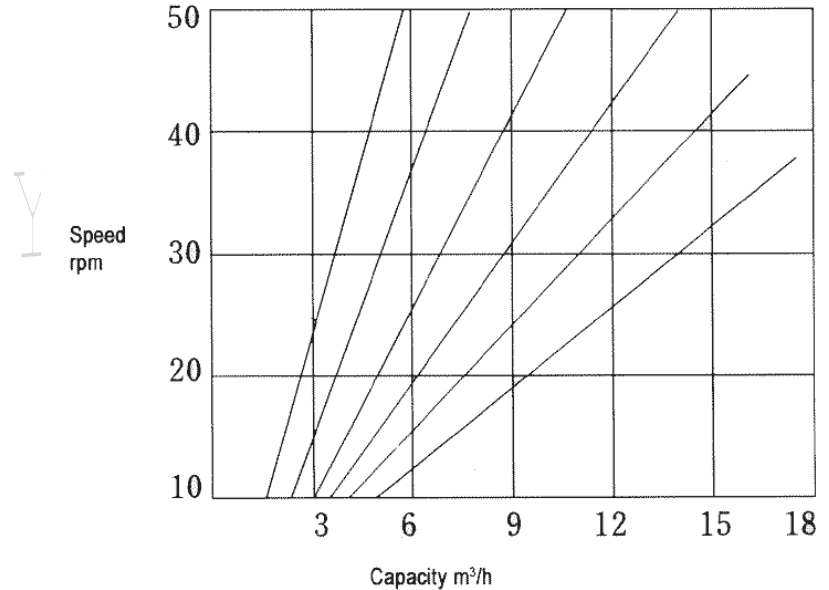

Typical Applications

- Toxic, flammable and volatile liquids.
- Strong acid, alkali and other corrosive liquids.
- Hot water retrieval and circulation.
- Oil loading & unloading in oil truck, oil depot and tanks.
- Paint, resin and dyes & glues.
- Ceramic glair, cement slurry and sludge.
- Sewage and remnant oil in oil vessels.
- Beer brewery and food processing.

Performance Data

Model	Capacity m³/h	Suction Head m	Head m	Discharge Pressure kg f/cm²	Motor		Temperature °C		Suction Discharge Diameter	Weight kg
					rpm / KW	C.I	st.st.			
DBY-10	0.5	3	30	3	1450/0.55	90	150	3/8" screw	50	
DBY-15	0.75	3	30	3	1450/0.55	90	150	1/2" screw	50	
DBY-25	3.5	4	30	3	1450/1.5	90	150	1" screw	170	
DBY-40	4.5	4	30	3	1450/2.2	90	150	1 1/2" screw	180	
DBY-50	6.5	4.5	30	3	1450/4	90	150	50mm Flange	400	
DBY-65	8	4.5	30	3	1450/4	90	150	65mm Flange	400	
DBY-80	16	5	30	3	1450/5.5	90	150	80mm Flange	610	
DBY-100	20	5	30	3	1450/5.5	90	150	100mm Flange	610	

Configuration Drawing & Installation Drawing

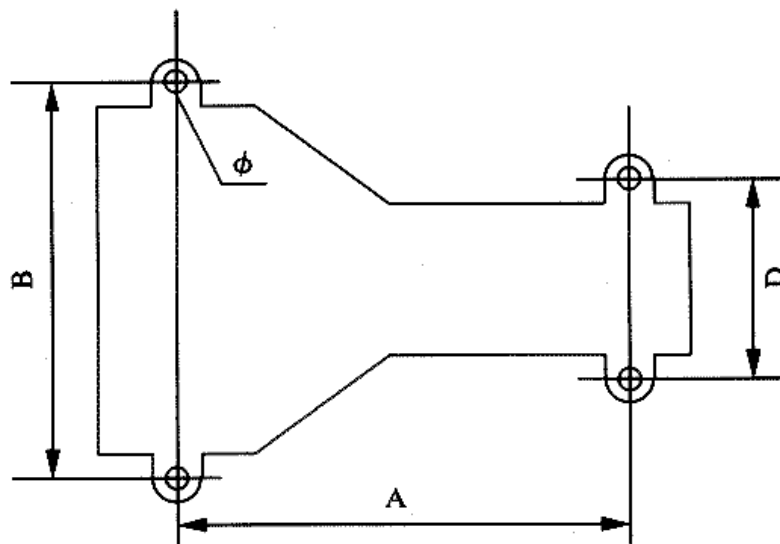
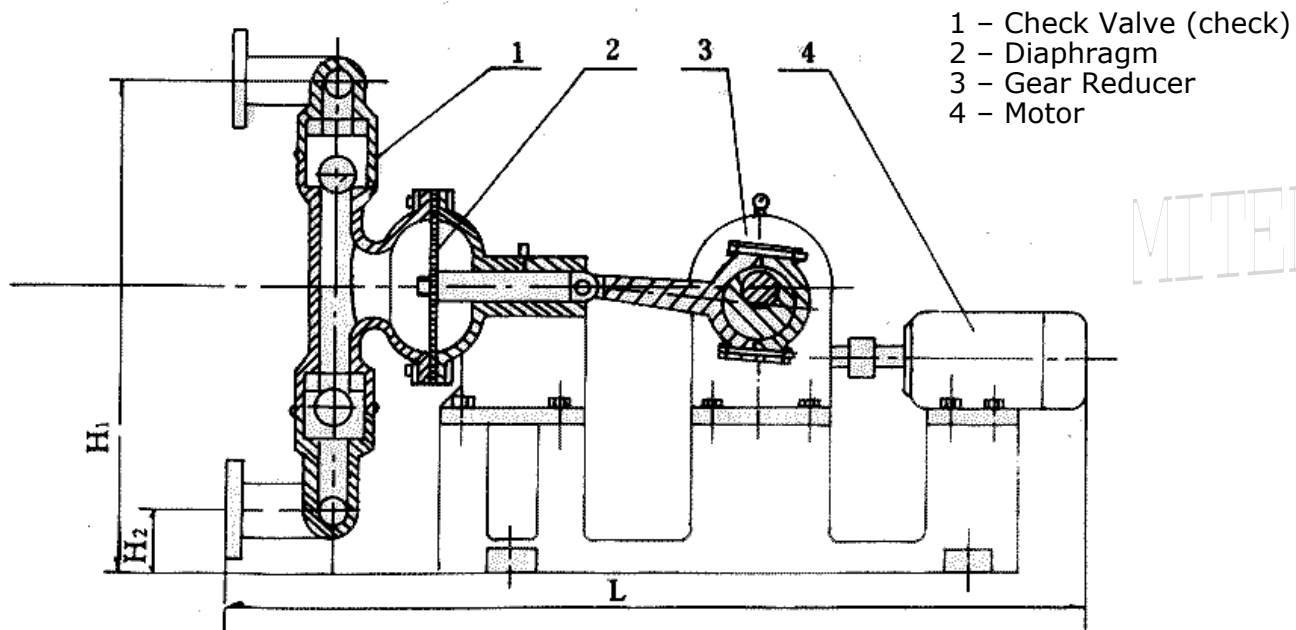

Model	A	B	D	ϕ	L	H1	H2
DBY-10	456	342	185	ϕ 12X4	650	370	50
DBY-15	456	342	185	ϕ 12X4	650	370	50
DBY-25	537	455	210	ϕ 14X4	1060	480	60
DBY-40	537	455	210	ϕ 14X4	1060	480	60
DBY-50	800	345	345	ϕ 16X4	1510	700	85
DBY-65	800	345	345	ϕ 16X4	1510	700	85
DBY-80	800	345	345	ϕ 18X4	1690	900	96
DBY-100	800	345	345	ϕ 18X4	1690	900	96