

EM1 Servo Motor Features

- Speeds up to 6000 RPM
- Encoder resolution option 17bits / 23bits
- High servo control bandwidth allows for precise angular motor positioning
- Quick and easy installation interface
- Rated output 50 W - 2 KW, IP65, optional brake and key



Optimize motor performance with E2 series Drives

Application

Semiconductor, Automated Optical Inspection, Bio-sequencing, Lab automation, Laser/Plasma cutting, Additive manufacturing, 3D printing, CNC parts feed/orientation, PCB assembly

1 Improved Processing Accuracy

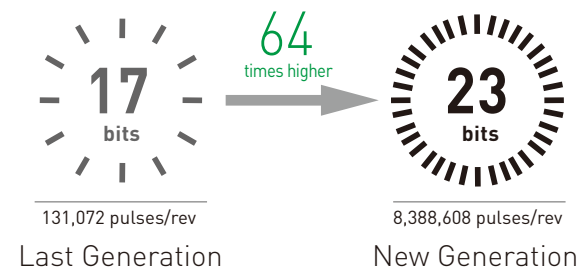

2 High Speed

6000 RPM. Max. torque improves by 310-350%.

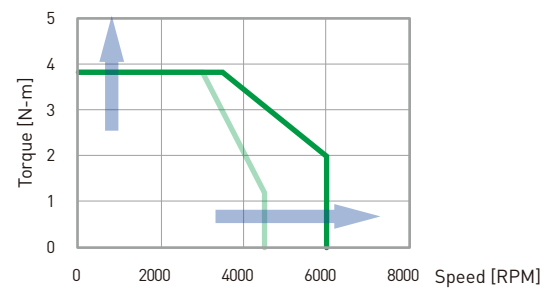

3 Compact Size

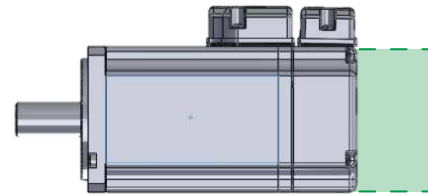

10% shorter than previous length. (Shown without brake.)

4 Advanced Auto-Tuning

Automatic loop gains tuning and filters optimize machine performance by suppressing vibration and resonance.

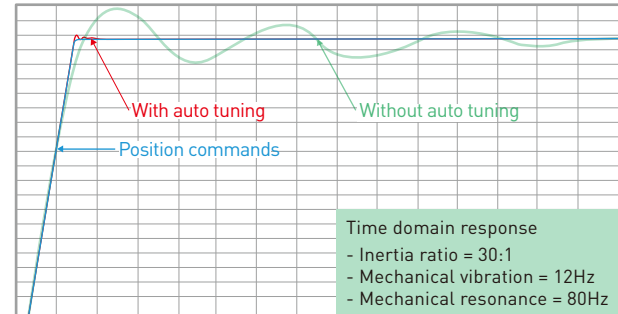

5 Tuneless Function

Good performance and stable movement with inertia ratio up to 250:1. Adaptive gain tuning in accordance with load changes.

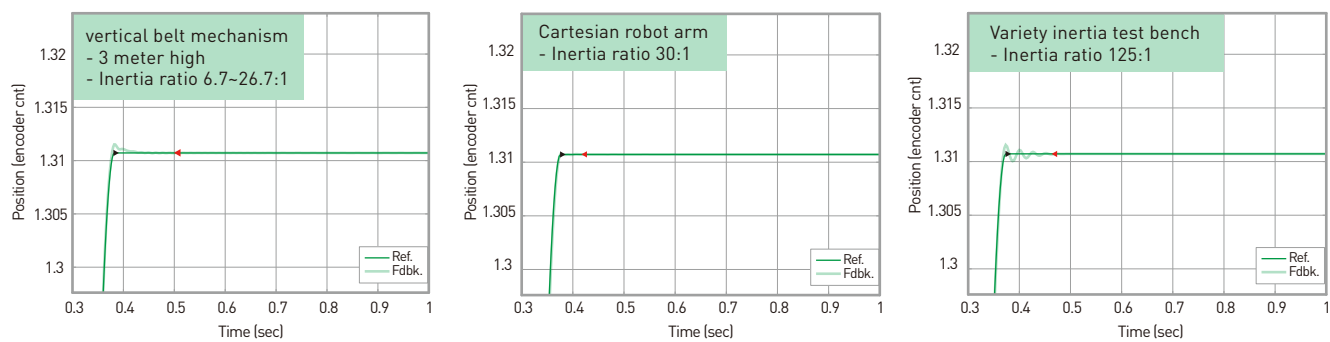

EM1 Motor Model Description

EM1-C-M-05-2-B-E-0-A

Rated Speed/Maximum Speed¹

A : 2000 / 3000(RPM)²
 C : 3000 / 6000(RPM)³
 D : 2000 / 5000(RPM)⁴

Inertia

M : Medium inertia

Output Power¹

05 : 50 W
 10 : 100 W
 20 : 200 W
 40 : 400 W
 75 : 750 W
 1K : 1000 W
 1A : 1200 W
 2K : 2000 W

Drive Input Voltage

2 : 220 Vac

Motor Shaft

A : Round shaft / without oil seal
 B : Round shaft / with oil seal
 C : With key and center tap / without oil seal
 D : With key and center tap / with oil seal

Reserved

0 : Standard

Encoder Type

C : 17 bits(incremental)
 D : 17 bits(absolute)
 E : 23 bits(incremental)
 F : 23 bits(absolute)

Holding Break Options

0 : Without holding brake
 B : With holding brake

- *1: Refer to the motor specification parameter table for the relationship between motor speed and power.
- *2: 1 kw
- *3: 50 w-750 w
- *4: 1.2 kw/2 kw

Series	Driver Input Voltage	Rated Power	Specification ^[Note1]	Drive Specification ^[Note2]	Cable Items			
					Power Extension Cable ^[Note3]		Encoder Extension Cable ^[Note3]	
					Without Holding Brake	With Holding Brake	Incremental	Absolute
EM1	Single/Three phase 220V	50W	EM1-C-M-05-2-□-□-0-□	ED2□-□□-003-1-A-00				
		100W	EM1-C-M-10-2-□-□-0-□					
		200W	EM1-C-M-20-2-□-□-0-□					
		400W	EM1-C-M-40-2-□-□-0-□					
		750W	EM1-C-M-75-2-□-□-0-□					
	Three phase 220V	1kW	EM1-A-M-1K-2-□-□-0-□	ED2□-□□-006-1-A-00				
		1.2kW	EM1-D-M-1A-2-□-□-0-□		HVPM04BA□□MB HVPM04CA□□MB	HVPM06BA□□MB HVPM06CA□□MB	HVE231AB□□MB HVE231CB□□MB	HVE23AAB□□MB HVE23ACB□□MB
		2kW	EM1-D-M-2K-2-□-□-0-□		HVPM04BB□□MB HVPM04CB□□MB	HVPM06BB□□MB HVPM06CB□□MB		

Note1 : Please refer E1 motor model description for options of motor shaft, oil seal and brake.

Note2 : Please refer to E2 drive model description (Except 2 kw)

Note3 : Standard Cable length is 3 m/ 5 m/ 7 m/ 10 m. □□: 03、05、07、10

Drive Wiring Diagrams

50 W-1.2 KW (used with E2 Drive)

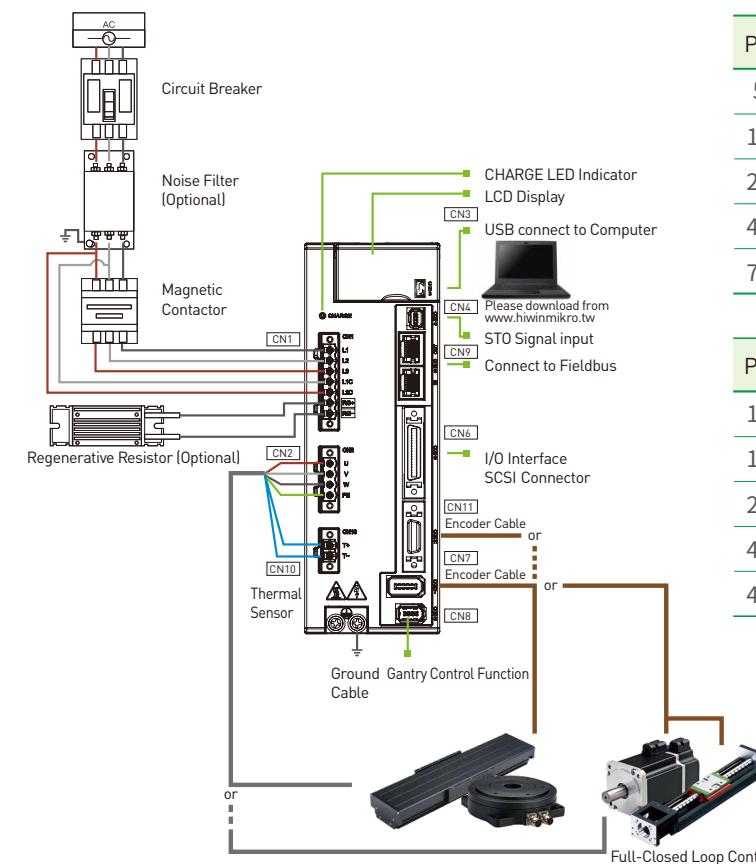

With Single-Axis Robot Description

Power	Spec.	With Single-Axis Robot (KK)			Max. Load (Parallel)	Max. Load (Vertical)
50 W	EM1-C-M-05	KK40	KK50	-	20 kg	10 kg
100 W	EM1-C-M-10	KK40	KK50	KK60D	30 kg	10 kg
200 W	EM1-C-M-20	KK80	KK86D	-	60 kg	20 kg
400 W	EM1-C-M-40	KK80	KK86D	KK100	80 kg	20 kg
750 W	EM1-C-M-75	KK130	-	-	100 kg	30 kg

Power	Spec.	With Single-Axis Robot (KA/KC)		Max. Load (Parallel)	Max. Load (Vertical)
100 W	EM1-C-M-10	KA100	-	30 kg	10 kg
100 W	EM1-C-M-10	KC50-B	-	10 kg	5 kg
200 W	EM1-C-M-20	KA136	KA170	50 kg	25 kg
400 W	EM1-C-M-40	KA136	KA170	100 kg	50 kg
400 W	EM1-C-M-40	KC80-B	-	80 kg	15 kg

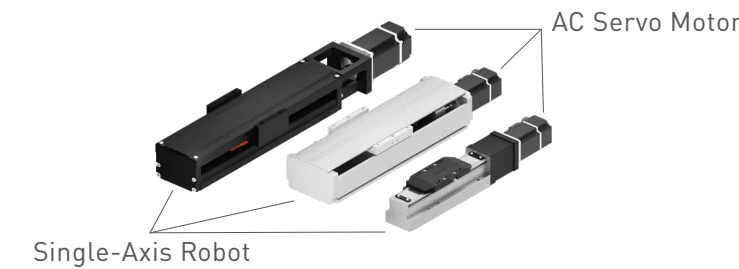

HIWIN MIKROSYSTEM

HIWIN MIKROSYSTEM New Generation AC Servo Motors



With HIWIN MIKROSYSTEM Drive E1/ E2

HIWIN MIKROSYSTEM

Global Sales And Customer Service Site

HIWIN MIKROSYSTEM CORP.
 No.6, Jingke Central Rd.,
 Taichung Precision Machinery Park,
 Taichung 40852, Taiwan
 Tel: +886-4-2355-0110
 Fax: +886-4-2355-0123
 www.hiwinmikro.tw
 business@hiwinmikro.tw

HIWIN GmbH
 OFFENBURG, GERMANY
 www.hiwin.de
 www.hiwin.eu
 info@hiwin.de

HIWIN Schweiz GmbH
 JONA, SWITZERLAND
 www.hiwin.ch
 info@hiwin.ch

HIWIN KOREA
 SUWON · CHANGWON, KOREA
 www.hiwin.kr
 info@hiwin.kr

HIWIN JAPAN
 KOBE · TOKYO · NAGOYA · TOHOKU ·
 NAGANO · SHIZUOKA · HOKURIKU ·
 HIROSHIMA · FUKUOKA · KUMAMOTO,
 JAPAN
 www.hiwin.co.jp
 info@hiwin.co.jp

HIWIN s.r.o.
 BRNO, CZECH REPUBLIC
 www.hiwin.cz
 info@hiwin.cz

HIWIN CHINA
 SUZHOU, CHINA
 www.hiwin.cn
 info@hiwin.cn

HIWIN USA
 CHICAGO, U.S.A.
 www.hiwin.us
 info@hiwin.com

HIWIN FRANCE
 STRASBOURG, FRANCE
 www.hiwin.fr
 info@hiwin.de

Mega-Fabs Motion Systems, Ltd.
 HAIFA, ISRAEL
 www.mega-fabs.com
 info@mega-fabs.com

HIWIN Srl
 BRUGHERIO, ITALY
 www.hiwin.it
 info@hiwin.it

HIWIN SINGAPORE
 SINGAPORE
 www.hiwin.sg
 info@hiwin.sg

E Series

AC Servo Motors & Drives

Specification

		Middle Inertia				
		50W	100W	200W	400W	
Motor Parameter	Symbol	Unit	EM1CM052□□□□	EM1CM102□□□□	EM1CM202□□□□	EM1CM402□□□□
Drive input voltage	V	V	AC220	AC220	AC220	AC220
Rated power	W	W	50	100	200	400
Rated torque	Tc	Nm	0.16	0.32	0.64	1.27
Rated current	Ic	A(rms)	0.64	0.78	1.6	2.5
Max. torque	Tp	Nm	0.59	1.18	2.24	4.44
Max. current	Ip	A(rms)	2.8	3.45	6.4	10
Rated speed	ωc	RPM	3000	3000	3000	3000
Max. speed	ωp	RPM	6000	6000	6000	6000
Torque constant	Kt	Nm / Arms	0.25	0.41	0.4	0.508
Back EMF constant	Ke	Vrms / KRPM	18.526	28.364	27.23	33.87
Resistance (line to line)	R	Ω	25.24	22.72	5.53	3.59
Inductance (line to line)	L	mH	13.09	13.86	8.76	7.22
Rotor inertia (with brake)	J	kg·m ² (×10 ⁻⁴)	0.0368 (0.0401)	0.0620 (0.0653)	0.263(0.326)	0.48(0.49)
Mass (with brake)	M	kg	0.36 (0.56)	0.47 (0.67)	0.851 (1.085)	1.25(1.8)
Insulation class	Class F					
Protection class	Total enclosed, self-cooled, IP65(except for shaft and connector)					
Insulation resistance	10MΩ, DC 500V					
Insulation voltage resistance	AC1500V, 60 seconds					
Holding Brake Specifications						
Static friction torque	Tb	Nm	0.32	0.32	1.3	1.3
Enabled current	Ab	A	0.25	0.25	0.32	0.32
Brake input voltage	V	V	DC24±10%	DC24±10%	DC24±10%	DC24±10%
Braking time	to	ms	40	40	30	30
Release time	tr	ms	20	20	20	20

E2 Series Drive Features

- 3.2 kHz speed response
- Tuneless function
- Advanced auto-tuning
- Ripple compensation
- Unique gantry control function
- Network with common industrial communication devices
- Drive-level 2D error compensation [GT Model]
- Supports various motor types
- Built-in STO function
- Supports various types of encoders such as Digital, Analog, Absolute: Tamagawa, EnDat, and BiSS-C

Applications

Industries related to Display, Semiconductor, 3D printing, CNC machining, medical, Automation, Laser cutting, and PCB.

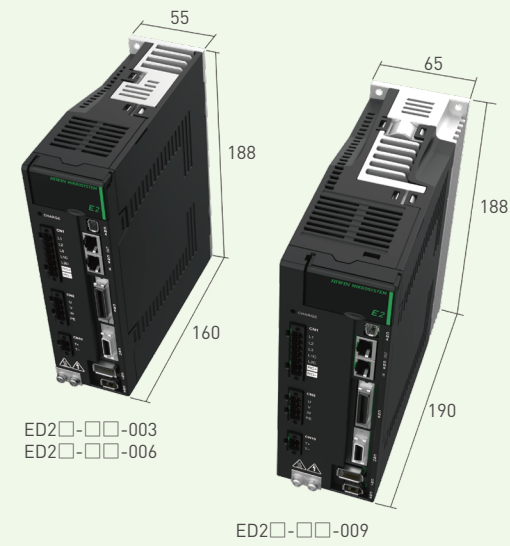

Middle Inertia

50W

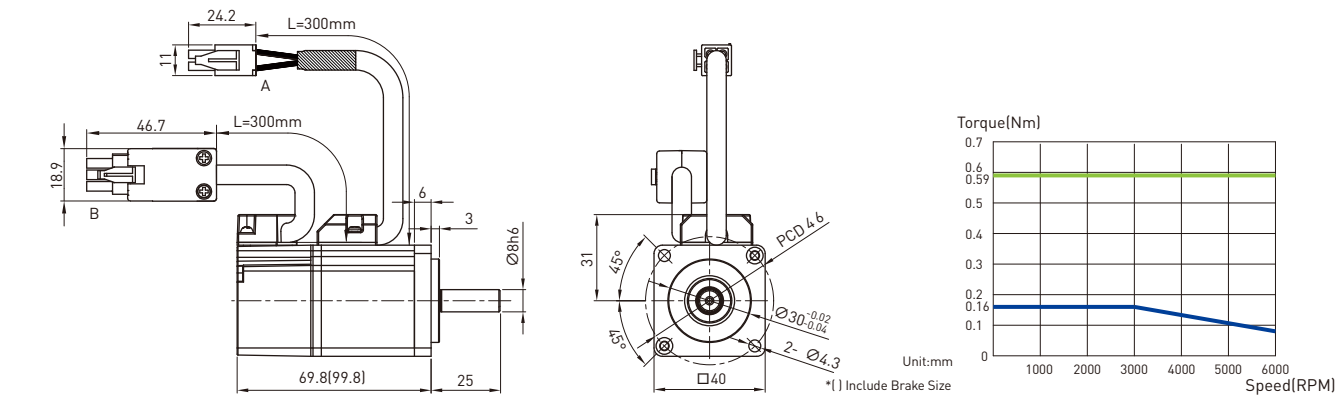

100W

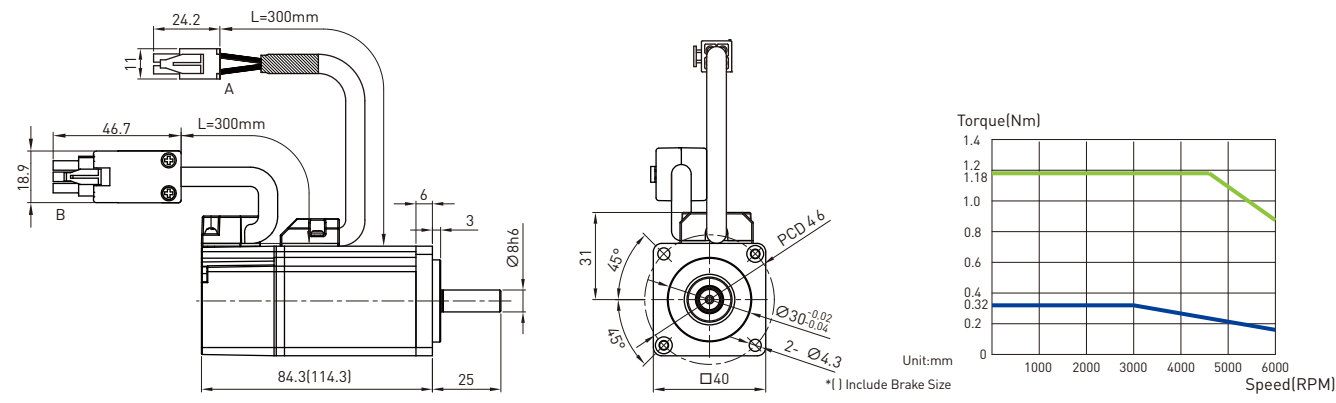

200W

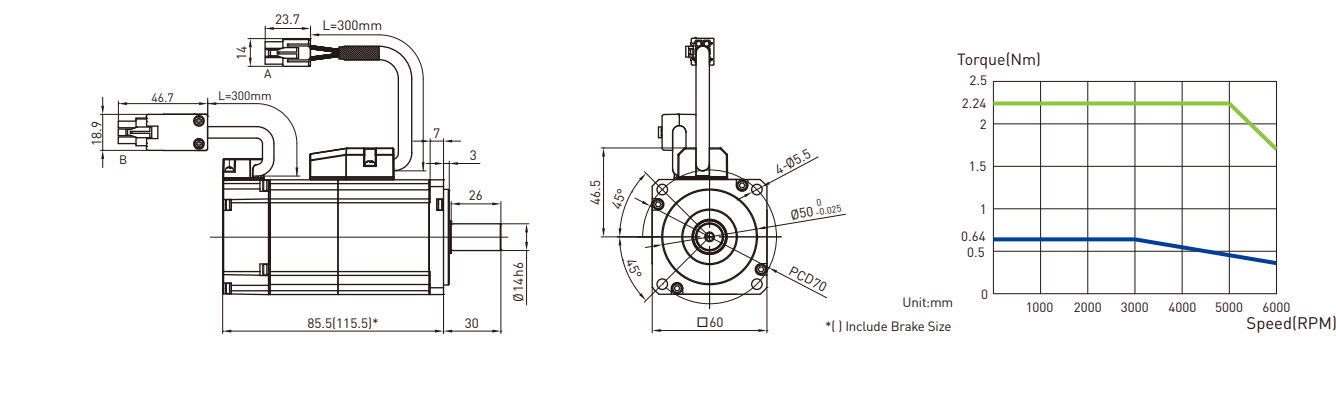

400W

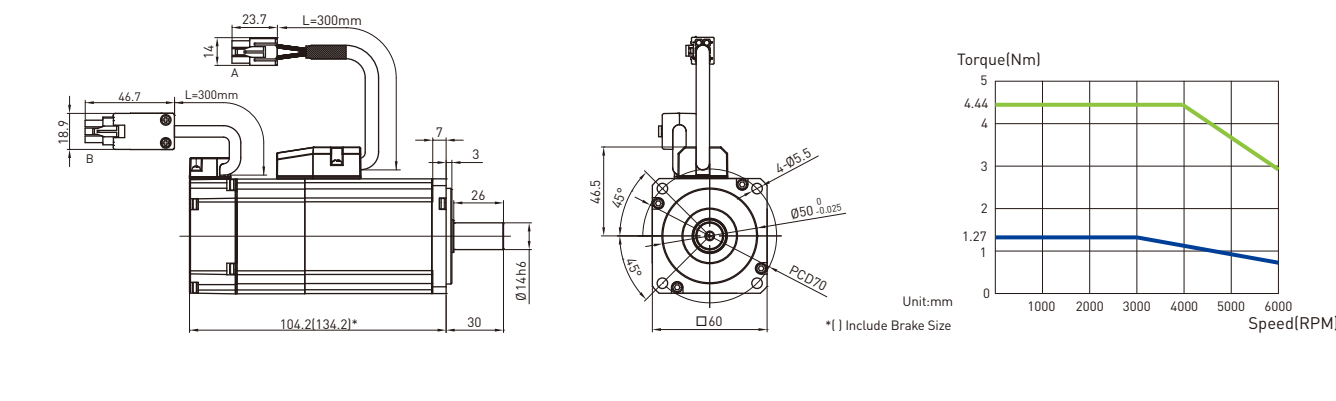

Middle Inertia

750W

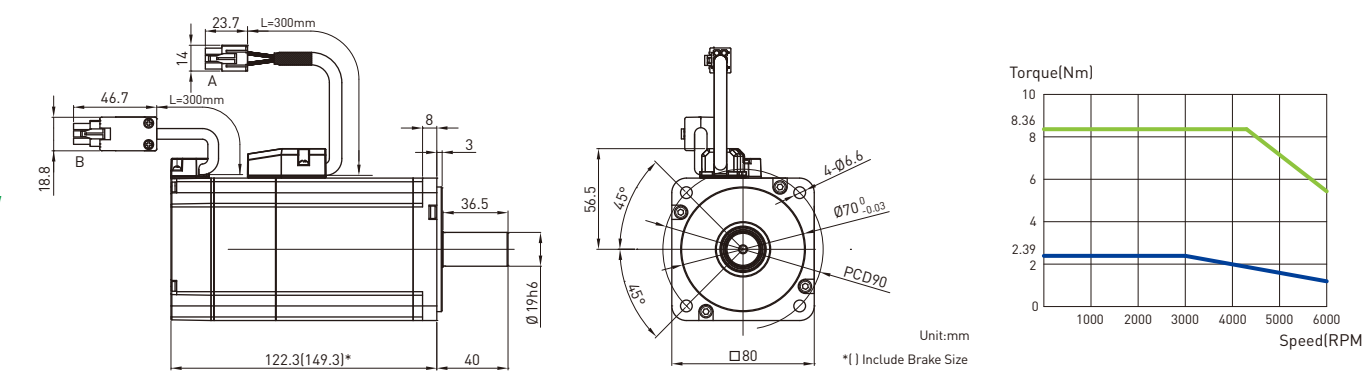

1KW

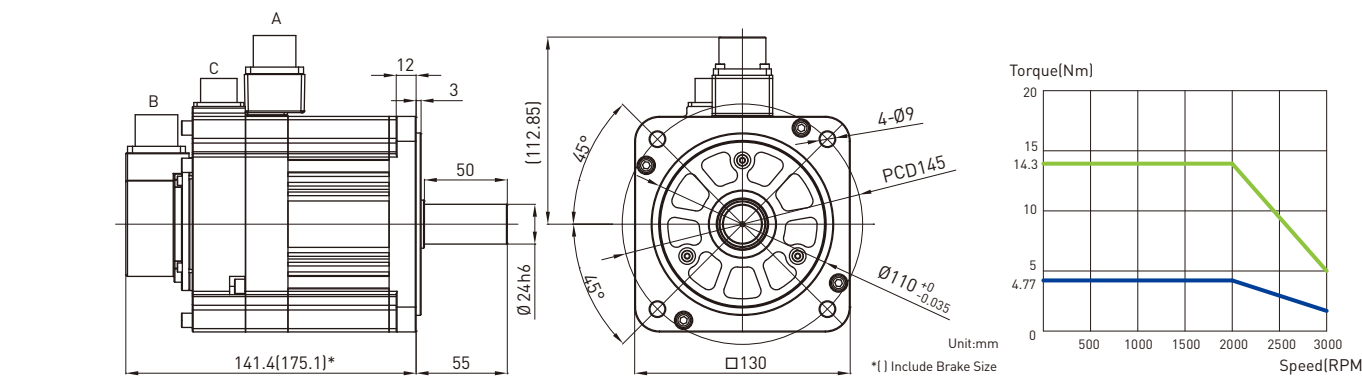

Middle Inertia, High Speed

1.2KW

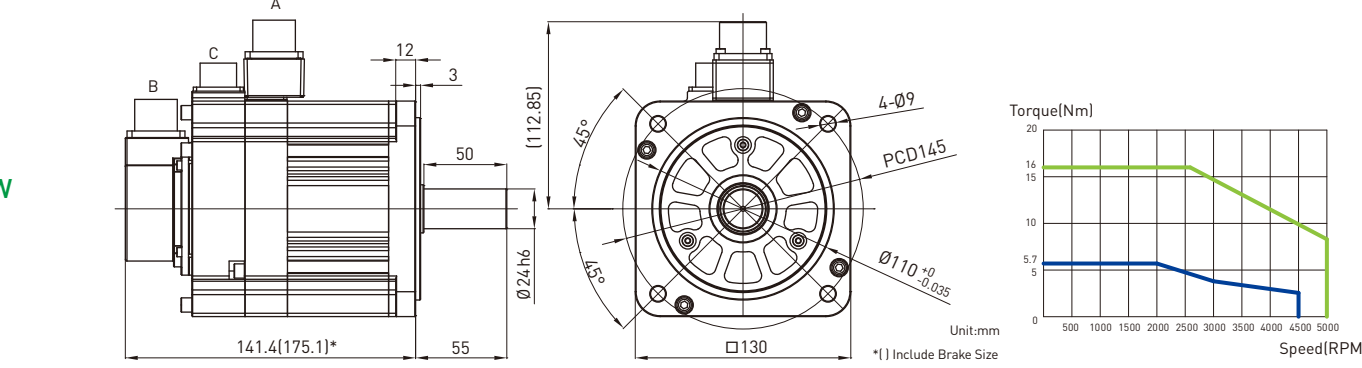

2KW

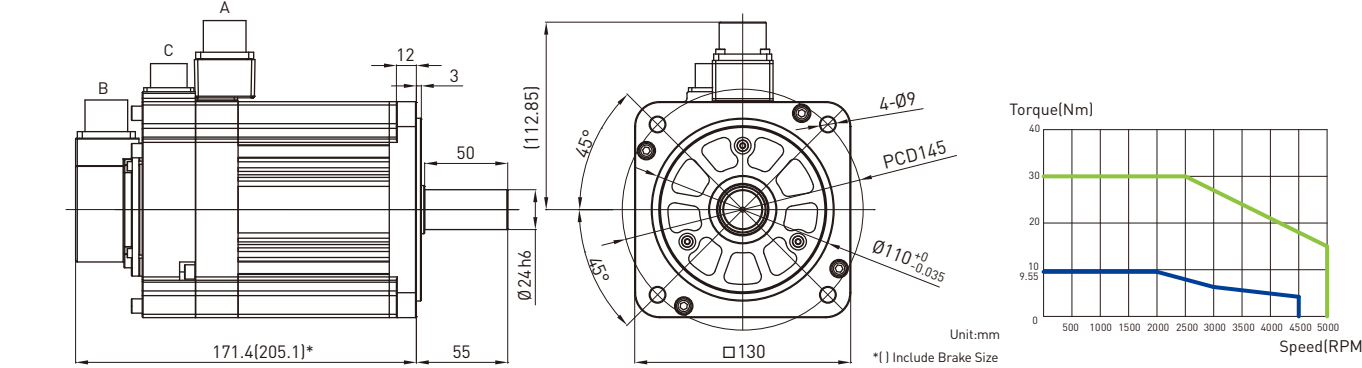

Middle Inertia

		Middle Inertia		Middle Inertia, High Speed		
		750W	1kW	1.2kW	2kW	
Motor Parameter	Symbol	Unit	EM1CM752□□□□	EM1AM1K2□□□□	EM1DM1A2□□□□	EM1DM2K2□□□□
Drive input voltage	V	V	AC220	AC220	AC220	AC220
Rated power	W	W	750	1000	1200	2000
Rated torque	Tc	Nm	2.39	4.77	5.73	9.55
Rated current	Ic	A(rms)	4.65	5.1	9.1	12
Max. torque	Tp	Nm	8.36	14.3	16	30
Max. current	Ip	A(rms)	18.6	15.3	27	42
Rated speed	ωc	RPM	3000	2000	2000	2000
Max. speed	ωp	RPM	6000	3000	5000	5000
Torque constant	Kt	Nm / Arms	0.514	0.935	0.63	0.796
Back EMF constant	Ke	Vrms / KRPM	33.48	54.15	41.52	50.49
Resistance (line to line)	R	Ω	1.08	0.81	0.482	0.264
Inductance (line to line)	L	mH	4.6	8	4.54	2.825
Rotor inertia (with brake)	J	kg·m ² (×10 ⁻⁴)	1.44 (1.47)	7.2 (8.0)	7.2 (8.0)	12.8 (13.3)
Mass (with brake)	M	kg	2.7 (3.36)	5.4 (6.2)	5.3 (6.1)	7.9 (8.7)
Insulation class	Class F					
Protection class	Total enclosed, self-cooled, IP65 (except for shaft and connector)					
Insulation resistance	10MΩ, DC 500V					
Insulation voltage resistance	AC1500V, 60 seconds					
Holding Brake Specifications						
Static friction torque	Tb	Nm	2.4	10	10	10
Enabled current	Ab	A	0.36	0.56	0.56	0.56
Brake input voltage	V	V	DC24 ±10%	DC24 ±10%	DC24 ±10%	DC24 ±10%
Braking time	to	ms	45	80	80	80
Release time	tr	ms	10	30	30	30

E2 Drive Model Description

E D 2 S - V 0 - 0 0 3 - 1 - C - 0 0

Type	S : Standard F : Fieldbus	Reserved
Control Interface	S V0 : Voltage command and Pulse E0 : EtherCAT [CoE] F H3 : HIWIN Motion Controller Mega-ulink over EtherCAT [MoE] ⁵	Function Model A : AC B : Basic C : Advanced T : GT
Rated Output	003 : 3 Arms (500 W) 006 : 6.3 Arms (1 kW) 009 : 9.4 Arms (1.2 kW)	AC Power Input 1 : Single/Three-phase 100~240 Vac (Rated 003, 006, 009) 2 : Three-phase 200~240 Vac (Not supported yet) 3 : Three-phase 380~480 Vac (Not supported yet)

Note : *5
It is used with HIWIN MoE HMC motion controller or API/MPI motion control command library. When using API/MPI motion control command library with servo drive, users should carefully read through "API/MPI Library Reference Manual" to confirm if Windows system is supported.